

*Orren's Cotton Factory, Stockport.*

THE  
PHILOSOPHY OF MANUFACTURES :  
OR,  
AN EXPOSITION  
OF THE  
SCIENTIFIC, MORAL, AND COMMERCIAL ECONOMY  
OF THE  
FACTORY SYSTEM  
OF  
Great Britain.

BY ANDREW URE, M.D., F.R.S.,

M.G.S., M.A.S. Lon., M. Acad. N.S. Philad.,  
S. Pharm. Soc. North Germany,  
&c. &c. &c.

---

LONDON :  
CHARLES KNIGHT, LUDGATE-STREET.

MDCCCXXXV.

## CONTENTS.

---

Preface . . . . .	Page vii
-------------------	-------------

---

### BOOK THE FIRST.

#### GENERAL PRINCIPLES OF MANUFACTURES.

##### CHAPTER I.

General View of Manufacturing Industry . . . . .	1
--	---

##### CHAPTER II.

Arrangement and Connexion of Manufactures . . . . .	55
---	----

##### CHAPTER III.

Topography and Statistics of the Factory System . . . . .	67
---	----

---

### BOOK THE SECOND.

#### SCIENTIFIC ECONOMY OF THE FACTORY SYSTEM.

##### CHAPTER I.

Examination of the Textile Fibres,—Cotton, Wool, Flax, and Silk . . . . .	81
--	----

##### CHAPTER II.

Nature, &c. of a Cotton Factory . . . . .	105
---	-----

##### CHAPTER III.

Worsted Manufacture—General Observations on Wool . . . . .	124
--	-----

##### CHAPTER IV.

Nature and Operations of a Woollen-Factory.—Of the Short Wool or Cloth Manufacture . . . . .	160
---	-----

##### CHAPTER V.

Nature and Operations of a Flax-Factory . . . . .	207
---	-----

	Page
CHAPTER VI.	
Nature and Operations of a Silk-Factory . . . .	229

---

BOOK THE THIRD.

MORAL ECONOMY OF THE FACTORY SYSTEM.

CHAPTER I.

Condition of our Factory Operatives, as to Personal Comforts, compared to that of other Labouring Classes; or the Quantity and Quality of their Work considered, relatively to the means of Enjoyment which it can procure.—History of the Discontents, Prejudices, and Legislation on this subject . . . .	277
---	-----

CHAPTER II.

Health of Factory Inmates . . . . .	374
-------------------------------------	-----

CHAPTER III.

State of Knowledge and Religion in the Factories . . . .	404
--	-----

---

BOOK THE FOURTH.

Commercial Economy of the Factory System . . . . .	430
Note A. . . . .	467
„ B. . . . .	470
„ C. . . . .	471
„ D. . . . .	472
APPENDIX—Relative Ages, Sexes, and Wages of Factory Work-people . . . . .	473
General Statistical Table of the Textile Manufactures, subject to the Factories Regulation Act . . . . .	481

---

☞ In the wages-column of table, page 373, the figures have been printed with horizontal lines, as vulgar fractions, instead of oblique lines, as shillings and pence. It should read 11s., 10s., 5s. 8d., 4s. 5d., 4s., 3s. 6d., 2s. 6d.

ERRATA.—Page 291, line 7, for “Of” read “On.”  
 „ 383, line 7, for “wires” read “wings.”

P R E F A C E.

---

THE present is distinguished from every preceding age by an universal ardour of enterprise in arts and manufactures. Nations convinced at length that war is always a losing game, have converted their swords and muskets into factory implements, and now contend with each other in the bloodless but still formidable strife of trade. They no longer send troops to fight on distant fields, but fabrics to drive before them those of their old adversaries in arms, and to take possession of a foreign mart. To impair the resources of a rival at home, by underselling his wares abroad, is the new belligerent system, in pursuance of which every nerve and sinew of the people are put upon the strain.

Great Britain may certainly continue to uphold her envied supremacy, sustained by her coal, iron, capital, and skill, if, acting on the Baconian axiom, “Knowledge is Power,” she shall diligently promote moral and professional culture among all ranks of her productive population. Were the principles of the manufactures exactly analyzed, and expounded in a simple manner, they would diffuse a steady light to conduct the masters, managers, and operatives, in the straight

paths of improvement, and prevent them from pursuing such dangerous phantoms as flit along in the monthly patent-lists. Each department of our useful arts stands in need of a guide-book to facilitate its study, to indicate its imperfections, and to suggest the most probable means of correcting them. It is known that the manufactures of France have derived great advantage from the illustrated systems of instruction published under the auspices of its government and patriotic societies.

The present volume, introductory to a series of works in more ample detail, is submitted to the public as a specimen of the manner in which the author conceives technological subjects should be discussed.

Having been employed in a public seminary for a quarter of a century, in expounding to practical men, as well as to youth, the applications of mechanical and chemical science to the arts, he felt it his duty, on being solicited from time to time by his pupils, now spread over the kingdom as proprietors and managers of factories, to prepare for publication a systematic account of their principles and processes. With this view he resolved to make afresh such a survey of some of the great manufacturing establishments, to which he had liberal access, as might qualify him to discharge the task in a creditable manner. This tour of verification would have been executed at a much earlier date, so as to have enabled him, ere now, to have redeemed his pledges both publicly and pri-

vately given, but for an interruption of unexpected magnitude.

The Right Honourable the Lords of the Committee of the Privy Council for Trade and Plantations requested him, about three years ago, to undertake a series of experiments on the refining of sugar, in order to ascertain the relation of the drawbacks on exportation of refined loaves to the duties paid upon the raw article. Under an impression that these researches might be set sufficiently in train, in the space of two or three months, to lead to the desired information in the hands of experienced operatives, he undertook their arrangement; but encountered so many difficulties from the delicacy of the material operated upon, and other circumstances stated in his official report printed by order of the House of Commons, that he did not get entirely extricated from them till nearly two years were expired, nor till he had suffered considerably from anxiety of mind and bodily fatigue. Being advised by his medical friends to try the effects of travelling, with light intellectual exercise, he left London in the latter end of last summer, and spent several months in wandering through the factory districts of Lancashire, Cheshire, Derbyshire, &c., with the happiest results to his health; having everywhere experienced the utmost kindness and liberality from the mill-proprietors. Neither they, nor the great mechanical engineers who construct their buildings and machinery, use any mystery or reserve towards a visiter actuated by legitimate feelings and

principles; but, on the contrary, most readily show and explain the curiously-productive inventions which surround them.

The few individuals who betray jealousy of intelligent inspection are usually vain persons, who, having purloined a few hints from ingenious neighbours, work upon them in secret, shut out every stranger from their mill, get consequently insulated and excluded in return, and thus, receiving no external illumination, become progressively adumbrated; till, after a few years of exclusive operation, they find themselves undersold in the market, and deprived of their oldest or best customers by the inferiority of their goods. Were it not invidious, the author could point out several examples of clever people, having thus outmanœuvred themselves, in trying to steal a march upon their friends in the dark. Mystifiers of this stamp are guilty of the silly blunder of estimating their own intrinsic resources above those of all the world beside. It is, however, not more for the advantage of the kingdom, than for that of every individual manufacturer in it, to receive light from all quarters, and to cause it by reflection to irradiate the sphere around him.

In tracing the progression of the British system of industry, according to which every process peculiarly nice, and therefore liable to injury from the ignorance and waywardness of workmen, is withdrawn from handicraft control, and placed under the guidance of self-acting machinery, the author has made it

his business to study the descriptions of most of the patents of that nature obtained in Great Britain, France, and America, during the last twenty years,—a task in which he has been assisted by Messrs. Newton and Berry, of Chancery-lane, gentlemen deservedly esteemed for the soundness of the specifications which they professionally prepare for patentees.

To James Cook, Esq., of Mincing-lane, he is indebted for the extensive assortment of samples of raw cotton, wool, flax, and silk, which have formed the principal subjects of his microscopic researches upon textile fibres, as also for much valuable information on the statistics of trade.

Nor ought he to leave unacknowledged the polite readiness of S. M. Phillipps, Esq., Under Secretary of State, and of Mr. Porter, of the Board of Trade, to aid his formation of a census of the factory population, and his inquiries into the commerce of the kingdom.

In delivering this general Treatise on Manufacturing Industry into the hands of the public, the author is not unconscious of defects, both in its matter and arrangement; for most of which, however, an apology may be found, in the vague and contradictory opinions entertained by experienced manufacturers on many departments of their business. Those of his readers who have most deeply considered the difficulties of his undertaking will not be the least indulgent.

The body of facts distributed throughout the volume have been most carefully verified, and will, it is pre-

sumed, bear the strictest scrutiny, though a desire to keep the volume at such a price as would bring its purchase within the reach of working-men has precluded the multiplication of notes of reference to authorities. The main portion of these, indeed, would have been to the reports of Parliamentary Committees; many great folios of which have been diligently consulted in quest of authentic information—though sometimes to little purpose—in consequence of the judgments of even honest men being strangely perverted by passion, prejudice, and self-interest.

The engravings at pages 48, 49, 120, 162, 271, 273, afford specimens of the original drawings of machines made under the author's eye, for illustrating modern manufactures; the complete series of which, when published in his forthcoming works on the cotton trade, dyeing, calico-printing, &c., will, it is hoped, constitute an interesting gallery of practical science.

*London, June 18th, 1835.*

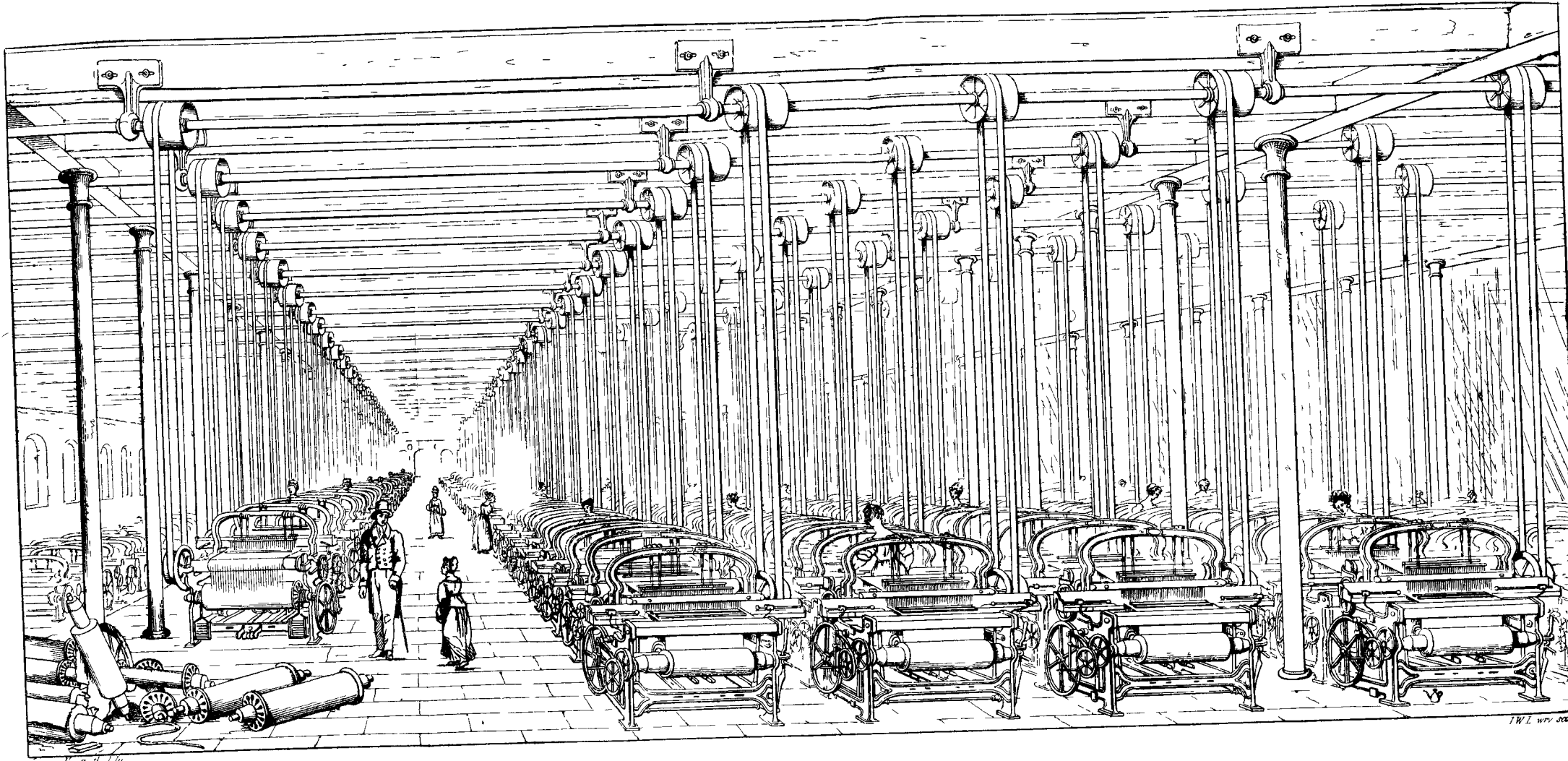

POWER LOOM FACTORY OF THOMAS ROBINSON ESQ<sup>R</sup>  
STOCKPORT.

# PHILOSOPHY OF MANUFACTURES.

---

BOOK THE FIRST.

## GENERAL PRINCIPLES OF MANUFACTURES.

---

CHAPTER I.

### *General View of Manufacturing Industry.*

MANUFACTURE is a word, which, in the vicissitude of language, has come to signify the reverse of its intrinsic meaning, for it now denotes every extensive product of art, which is made by machinery, with little or no aid of the human hand; so that the most perfect manufacture is that which dispenses entirely with manual labour. The philosophy of manufactures is therefore an exposition of the general principles, on which productive industry should be conducted by self-acting machines. The end of a manufacture is to modify the texture, form, or composition of natural objects by mechanical or chemical forces, acting either separately, combined, or in succession. Hence the automatic arts subservient to general commerce may be distinguished into Mechanical and Chemical, according as they modify the external form or the internal constitution of their subject matter. An indefinite variety of objects may be subjected to each system of action, but they



may be all conveniently classified into animal, vegetable, and mineral.

A mechanical manufacture being commonly occupied with one substance, which it conducts through metamorphoses in regular succession, may be made nearly automatic; whereas a chemical manufacture depends on the play of delicate affinities between two or more substances, which it has to subject to heat and mixture under circumstances somewhat uncertain, and must therefore remain, to a corresponding extent, a manual operation. The best example of *pure* chemistry on self-acting principles which I have seen, was in a manufacture of sulphuric acid, where the sulphur being kindled and properly set in train with the nitre, atmospheric air, and water, carried on the process through a labyrinth of compartments, and supplied the requisite heat of concentration, till it brought forth a finished commercial product. The finest model of an automatic manufacture of *mixed* chemistry is the five-coloured calico machine, which continuously, and spontaneously, so to speak, prints beautiful webs of cloth with admirable precision and speed. It is in a cotton mill, however, that the perfection of automatic industry is to be seen; it is there that the elemental powers have been made to animate millions of complex organs, infusing into forms of wood, iron, and brass an intelligent agency. And as the philosophy of the fine arts, poetry, painting, and music may be best studied in their individual master-pieces, so may the philosophy of manufactures in this its noblest creation.

There are four distinct classes of textile fibres, cotton, wool, flax, and silk, which constitute the subjects of four, or, more correctly speaking, five distinct classes

of factories; first, the cotton factories; second, the woollen; third, the worsted; fourth, the flax, hempen, or linen; and fifth, the silk. These five factories have each peculiarities proceeding from the peculiarities of its raw material and of its fabrics; but they all possess certain family features, for they all employ torsion to convert the loose slender fibres of vegetable or animal origin into firm coherent threads, and, with the exception of silk, they all employ extension also to attenuate and equalize these threads, technically styled yarn. Even one kind of silk which occurs in entangled tufts, called floss, is spun like cotton, by the simultaneous action of stretching and twisting.

The above-named five orders of factories are, throughout this kingdom, set in motion by steam-engines or water-wheels; they all give employment to multitudes of children or adolescents; and they have therefore been subjected to certain legislative provisions, defined in the *Factories Regulation Act*, passed by Parliament on the 29th August, 1833.

It is probable that 614,200 work-people are constantly engaged within the factories of the United Kingdom: of which number 561,900 belong to England and Wales; 46,825 to Scotland; and 5,475 to Ireland.\* Fully five-tenths of them are under twenty-one years of age, and three tenths of these young persons are females. It must be remembered, however, that besides these 614,200 inmates of factories, a vast population

\* The above numbers for Scotland and Ireland are taken from Mr. Leonard Horner's excellent Report as Factory Inspector; the number for England is computed on the recognized *datum* that it is twelve times greater for the cotton trade than that of Scotland. For the last official details see the Appendix.

derives a livelihood from the manufactures of cotton, wool, flax, and silk, such as the hand-weavers, the calico-printers and dyers, the frame-work knitters, the lace-makers, lace-runners, muslin-sewers, &c. &c.

It appears from the Parliamentary Returns of 1831, that in Great Britain, out of a total population of 16,539,318 persons, there are of

Agricultural Labourers and Labour-  
ing Occupiers .....1,055,982, and of

Manufacturing Labourers .....404,317

Whence there are 1000 agricultural to 383 strictly manufacturing labourers.

Persons employed in retail trade, or  
in handicraft, as masters or work-  
men .....1,159,867

Total adult persons employed in arts  
and trades .....1,564,184, being  
about fifty per cent. more than those engaged in agri-  
culture.

The capitalists, bankers, professional  
and other educated men amount to 214,390  
Labourers non-agricultural to .....618,712

If we include in the agricultural de-  
partment, the occupiers employing  
labourers (few of whom, however,  
work), we shall have to add .....187,075  
to the above number .....1,055,057

The total sum of Agriculturists is 1,243,057, being  
only 80 per cent. of the adult males employed in manu-  
factures, arts, and trades.

When we take into account the vastly greater propor-  
tion of young persons constantly occupied with factory  
labour, than of those occupied with agricultural labour,  
we shall then be led to conclude that at least double  
the amount of personal industry is engaged in the arts,  
manufactures, and trade, to what is engaged in agricul-  
ture. Considerably upwards of one-tenth of the popu-  
lation of this island is actually employed in manu-  
factures; and probably little more than one-fifteenths  
in agriculture. This conclusion ought to lead our legis-  
lative landlords to treat the manufacturing interests  
with greater respect than they have usually been accus-  
tomed to do. If we consider, moreover, how much  
greater a mass of productive industry a male adult is  
equivalent to, in power-driven manufactures, than in  
agriculture, the balance in favour of the former will be  
greatly enhanced.

France, which has for upwards of a century and a half  
tried every scheme of public premium to become a great  
manufacturing country, has a much less proportion  
than one employed in trade for two employed in agri-  
culture. M. Charles Dupin, indeed, has been led by  
his researches into the comparative industry of France  
and of the United Kingdom, to conclude that the  
agricultural produce of our country amounted in value  
to 240 millions sterling, and that of his own to 180  
millions sterling, being the ratio of three to two;  
and that our manufacturing power is inferior to that  
of France in the proportion of sixty-three to seventy-  
two; or as seven to eight. There can be no doubt  
that his agricultural estimate underrates France, as  
much as his manufacturing estimate underrates Great  
Britain.

This island is pre-eminent among civilized nations for the prodigious development of its factory wealth, and has been therefore long viewed with a jealous admiration by foreign powers. This very pre-eminence, however, has been contemplated in a very different light by many influential members of our own community, and has been even denounced by them as the certain origin of innumerable evils to the people, and of revolutionary convulsions to the state. If the affairs of the kingdom be wisely administered, I believe such allegations and fears will prove to be groundless, and to proceed more from the envy of one ancient and powerful order of the commonwealth, towards another suddenly grown into political importance than from the nature of things.

In the recent discussions concerning our factories, no circumstance is so deserving of remark, as the gross ignorance evinced by our leading legislators and economists, gentlemen well informed in other respects, relative to the nature of those stupendous manufactures which have so long provided the rulers of the kingdom with the resources of war, and a great body of the people with comfortable subsistence; which have, in fact, made this island the arbiter of many nations, and the benefactor of the globe itself.\* Till this ignorance be dispelled, no sound legislation need be expected on manufacturing subjects. To effect this purpose is a principal, but not the sole aim of the present volume,

\* Even the eminent statesman lately selected by his Sovereign to wield the destinies of this commercial empire—Sir Robert Peel, who derives his family consequence from the cotton trade, seems to be but little conversant with its nature and condition.—See Dr. Carbutt's observations on the subject, next page.

for it is intended also to convey specific information to the classes directly concerned in the manufactures, as well as general knowledge to the community at large, and particularly to young persons about to make the choice of a profession.

The blessings which physico-mechanical science has bestowed on society, and the means it has still in store for ameliorating the lot of mankind, have been too little dwelt upon; while, on the other hand, it has been accused of lending itself to the rich capitalists as an instrument for harassing the poor, and of exacting from the operative an accelerated rate of work. It has been said, for example, that the steam-engine now drives the power-looms with such velocity as to urge on their attendant weavers at the same rapid pace; but that the hand-weaver, not being subjected to this restless agent, can throw his shuttle and move his treddles at his convenience. There is, however, this difference in the two cases, that in the factory, every member of the loom is so adjusted, that the driving force leaves the attendant nearly nothing at all to do, certainly no muscular fatigue to sustain, while it procures for him good, unfailing wages, besides a healthy workshop *gratis*: whereas the non-factory weaver, having everything to execute by muscular exertion, finds the labour irksome, makes in consequence innumerable short pauses, separately of little account, but great when added together; earns therefore proportionally low wages, while he loses his health by poor diet and the dampness of his hovel. Dr. Carbutt of Manchester says, "With regard to Sir Robert Peel's assertion a few evenings ago, that the hand-loom weavers are mostly small farmers, nothing can be a greater mistake; they live, or rather they just keep life

together, in the most miserable manner, in the cellars and garrets of the town, working sixteen or eighteen hours for the merest pittance.”\*

The constant aim and effect of scientific improvement in manufactures are philanthropic, as they tend to relieve the workmen either from niceties of adjustment which exhaust his mind and fatigue his eyes, or from painful repetition of effort which distort or wear out his frame. At every step of each manufacturing process described in this volume, the humanity of science will be manifest. New illustrations of this truth appear almost every day, of which a remarkable one has just come to my knowledge. In the woollen-cloth trade there is a process between carding and spinning the wool, called *slubbing*, which converts the spongy rolls, turned off from the cards, into a continuous length of fine porous cord. Now, though carding and spinning lie within the domain of automatic science, yet *slubbing* is a handicraft operation, depending on the skill of the slubber, and participating therefore in all his irregularities. If he be a steady, temperate man, he will conduct his business regularly, without needing to harass his juvenile assistants, who join together the series of card rolls, and thus feed his machine; but if he be addicted to liquor, and passionate, he has it in his power to exercise a fearful despotism over the young pieceners, in violation of the proprietor's benevolent regulations. This class of operatives, who, though inmates of factories, are not, properly speaking, factory workers, being independent of the moving power, have been the principal source of the obloquy so unsparingly

\* Letter of 3rd of May, 1833, to Dr. Hawkins in his Medical Report, Factory Commission, p. 282.

cast on the cotton and other factories, in which no such capricious practices or cruelties exist. The wool slubber, when behind hand with his work, after a visit to the beer-shop, resumes his task with violence, and drives his machine at a speed beyond the power of the pieceners to accompany; and if he finds them deficient in the least point, he does not hesitate to lift up the long wooden rod from his slubbing-frame, called a billy-roller, and beat them unmercifully. I rejoice to find that science now promises to rescue this branch of the business from handicraft caprice, and to place it, like the rest, under the safeguard of automatic mechanism. The details of this recent invention will be given in describing the woollen manufacture.

The processes that may be employed, to give to portions of inert matter, precise movements resembling those of organized beings, are innumerable, as they consist of an indefinite number and variety of cords, pulleys, toothed-wheels, nails, screws, levers, inclined-planes, as well as agencies of air, water, fire, light, &c., combined in endless modes to produce a desired effect. Ingenuity has been long exercised on such combinations, chiefly for public amusement or mystification, without any object of utility. In ancient times the statue of Memnon was celebrated for emitting harmonious sounds at sun-rise, and acted probably by concealed organ-pipes. The flying pigeon of Archytas was more manifestly an automatic mechanism, as it performed all the motions of an animal; and likewise the Android of Albert the Great, which opened a door when any one knocked, and muttered certain sounds, as if speaking to the visitor. The brass heads, or conversible busts of Abbé Mical, were probably a simple

acoustic experiment on the transmission of sounds through tubes, like the Invisible Girl. More recently the flute-player of Vaucanson has puzzled the world. It presented the appearance of a human figure of the ordinary size, seated on a piece of rock, supported on a pedestal four feet and a half high. By the movements of its lips, fingers, and tongue, it modified the tones of the flute, and executed twelve different airs on the instrument. Vaucanson constructed also a drummer, which played on a flute with a three-holed mouth-piece, no less than twenty airs. Standing upright on a pedestal, dressed like a dancing shepherd, holding its flageolet in one hand, and a rod in the other, it beat the drum at one time in single taps, and at another in a long roll, as accompaniments to the flageolet tune. This automaton seemed to be truly the animated leader of the pleasures of a ball, skilful in augmenting or diminishing the breathing sounds of its instrument, with equal precision and taste.

The duck of the same celebrated mechanician, not only imitated the different movements of this animal, drinking, gobbling, swallowing, &c., but also represented faithfully the structure of the internal viscera for the digestion of the food. The play of every part necessary to discharge these functions was imitated to the life; for the duck drank, dabbled in the water, stretched out its neck to take grain when offered to it in the hand, drew back its head again to swallow it, doubled the quickness of the masticating movements in passing the grain into the stomach, like the living duck, which always swallows its food very hastily. The grain was then ground in the gizzard, as preparatory to digestion; and finally subjected to excrementitious

actions. Its wings, neck, head, and whole frame, were imitated bone by bone, and arranged in their natural form and order. When once wound up, the duck went through all its vital evolutions without needing to be touched. These machines were purchased by Professor Bayreuss, of Helmstadt.

The chess-player of M. Maelzel, now under exhibition at Paris, and formerly shown in this country, has been often described. It imitates very remarkably a living being, endowed with all the resources of intelligence, for executing the combinations of profound study.

Raisin's automaton harpsichord was found to contain an infant performer.

Self-acting inventions like the preceding, however admirable as exercises of mechanical science, do nothing towards the supply of the physical necessities of society. Man stands in daily want of food, fuel, clothing, and shelter; and is bound to devote the powers of body and mind, of nature and art, in the first place to provide for himself and his dependents a sufficiency of these necessities, without which there can be no comfort, nor leisure for the cultivation of the taste and intellect. To the production of food and domestic accommodation, not many automatic inventions have been applied, or seem to be extensively applicable; though, for modifying them to the purposes of luxury, many curious contrivances have been made. Machines, more or less automatic, are embodied in the coal-mines of Great Britain; but such combinations have been mainly directed, in this as well as other countries, to the materials of clothing. These chiefly consist of flexible fibres of vegetable or animal origin, twisted into smooth, tenacious threads, which are then woven into cloth by

being decussated in a loom. Of the animal kingdom, silk, wool, and hair, are the principal textile products. The vegetable tribes furnish cotton, flax, hemp, besides several other fibrous substances of inferior importance.

Wool, flax, hemp, and silk, have been very generally worked up among the nations of Europe, both in ancient and modern times; but cotton attire was, till sixty years ago, confined very much to Hindostan, and some other districts of Asia. No textile filaments however are, by their facility of production as well as their structure, so well adapted as those of cotton to furnish articles of clothing, combining comfort with beauty and convenience in an eminent degree. Hence we can understand how cotton fabrics, in their endless variety of textures and styles, plain, figured, and coloured, have within the short period of one human life, grown into an enormous manufacture, have become an object of the first desire to mankind all over the globe, and of zealous industry to the most civilized states. This business has received its great automatic development in England, though it was cultivated to a considerable extent on handicraft principles in France a century ago, and warmly encouraged by the government of that country, both as to the growth of the material and its conversion into cloth. The failure of the French however to establish a factory system prior to the English is a very remarkable fact, and proves clearly that mechanical invention, for which the former nation have long been justly celebrated, is not of itself sufficient to found a successful manufacture.

We have adverted to the mechanisms of Vaucanson. This inventive artisan directed his attention also to productive machines. He constructed one for winding

silk so long ago as 1749; one for doubling and twisting it in 1751; a tapestry loom in 1758; another for winding silk in 1770; a machine for laminating stuffs in 1757, and a plan of mounting silk-mills in 1776. There can be no doubt as to the value of these inventions, as they were described with merited eulogiums in the above named years by the Academy of Paris. In 1776 he published an account of the Indian mode of weaving fine muslins in the wet state, showing that his attention had been turned likewise to the cotton trade.

The term *Factory*, in technology, designates the combined operation of many orders of work-people, adult and young, in tending with assiduous skill a system of productive machines continuously impelled by a central power. This definition includes such organizations as cotton-mills, flax-mills, silk-mills, woollen-mills, and certain engineering works; but it excludes those in which the mechanisms do not form a connected series, nor are dependent on one prime mover. Of the latter class, examples occur in iron-works, dye-works, soap-works, brass-foundries, &c. Some authors, indeed, have comprehended under the title *factory*, all extensive establishments wherein a number of people co-operate towards a common purpose of art; and would therefore rank breweries, distilleries, as well as the workshops of carpenters, turners, coopers, &c., under the factory system. But I conceive that this title, in its strictest sense, involves the idea of a vast automaton, composed of various mechanical and intellectual organs, acting in uninterrupted concert for the production of a common object, all of them being subordinated to a self-regulated moving

force. If the marshalling of human beings in systematic order for the execution of any technical enterprise were allowed to constitute a factory, this term might embrace every department of civil and military engineering; a latitude of application quite inadmissible.

In its precise acceptation, the Factory system is of recent origin, and may claim England for its birth-place. The mills for throwing silk, or making organzine, which were mounted centuries ago in several of the Italian states, and furtively transferred to this country by Sir Thomas Lombe in 1718, contained indeed certain elements of a factory, and probably suggested some hints of those grander and more complex combinations of self-acting machines, which were first embodied half a century later in our cotton manufacture by Richard Arkwright, assisted by gentlemen of Derby, well acquainted with its celebrated silk establishment. But the spinning of an entangled flock of fibres into a smooth thread, which constitutes the main operation with cotton, is in silk superfluous; being already performed by the unerring instinct of a worm, which leaves to human art the simple task of doubling and twisting its regular filaments. The apparatus requisite for this purpose is more elementary, and calls for few of those gradations of machinery which are needed in the carding, drawing, roving, and spinning processes of a cotton-mill.

When the first water-frames for spinning cotton were erected at Cromford, in the romantic valley of the Derwent, about sixty years ago, mankind were little aware of the mighty revolution which the new system of labour was destined by Providence to achieve, not only in the structure of British society, but in the for-

tunes of the world at large. Arkwright alone had the sagacity to discern, and the boldness to predict in glowing language, how vastly productive human industry would become, when no longer proportioned in its results to muscular effort, which is by its nature fitful and capricious, but when made to consist in the task of guiding the work of mechanical fingers and arms, regularly impelled with great velocity by some indefatigable physical power. What his judgment so clearly led him to perceive, his energy of will enabled him to realize with such rapidity and success, as would have done honour to the most influential individuals, but were truly wonderful in that obscure and indigent artisan. The main difficulty did not, to my apprehension, lie so much in the invention of a proper self-acting mechanism for drawing out and twisting cotton into a continuous thread, as in the distribution of the different members of the apparatus into one co-operative body, in impelling each organ with its appropriate delicacy and speed, and above all, in training human beings to renounce their desultory habits of work, and to identify themselves with the unvarying regularity of the complex automaton. To devise and administer a successful code of factory discipline, suited to the necessities of factory diligence, was the Herculean enterprise, the noble achievement of Arkwright. Even at the present day, when the system is perfectly organized, and its labour lightened to the utmost, it is found nearly impossible to convert persons past the age of puberty, whether drawn from rural or from handicraft occupations, into useful factory hands. After struggling for a while to conquer their listless or restive habits, they either renounce the employment sponta-

neously, or are dismissed by the overlookers on account of inattention.

If the factory Briareus could have been created by mechanical genius alone, it should have come into being thirty years sooner; for upwards of ninety years have now elapsed since John Wyatt, of Birmingham, not only invented the series of fluted rollers, (the spinning fingers usually ascribed to Arkwright,) but obtained a patent for the invention, and erected "a spinning engine without hands" in his native town. The details of this remarkable circumstance, recently snatched from oblivion, will be given in our Treatise on the Cotton Manufactures. Wyatt was a man of good education, in a respectable walk of life, much esteemed by his superiors, and therefore favourably placed, in a mechanical point of view, for maturing his admirable scheme. But he was of a gentle and passive spirit, little qualified to cope with the hardships of a new manufacturing enterprise. It required, in fact, a man of a Napoleon nerve and ambition, to subdue the refractory tempers of work-people accustomed to irregular paroxysms of diligence, and to urge on his multifarious and intricate constructions in the face of prejudice, passion, and envy. Such was Arkwright, who, suffering nothing to stay or turn aside his progress, arrived gloriously at the goal, and has for ever affixed his name to a great era in the annals of mankind, an era which has laid open unbounded prospects of wealth and comfort to the industrious, however much they may have been occasionally clouded by ignorance and folly.

Prior to this period, manufactures were everywhere feeble and fluctuating in their development; shooting forth luxuriantly for a season, and again

withering almost to the roots, like annual plants. Their perennial growth now began in England, and attracted capital in copious streams to irrigate the rich domains of industry. When this new career commenced, about the year 1770, the annual consumption of cotton in British manufactures was under four millions of pounds weight, and that of the whole of Christendom was probably not more than ten millions. Last year the consumption in Great Britain and Ireland was about two hundred and seventy millions of pounds, and that of Europe and the United States together four hundred and eighty millions. This prodigious increase is, without doubt, almost entirely due to the factory system founded and upreared by the intrepid native of Preston. If then this system be not merely an inevitable step in the social progression of the world, but the one which gives a commanding station and influence to the people who most resolutely take it, it does not become any man, far less a denizen of this favoured land, to vilify the author of a benefaction, which, wisely administered, may become the best temporal gift of Providence to the poor, a blessing destined to mitigate, and in some measure to repeal, the primeval curse pronounced on the labour of man, "in the sweat of thy face shalt thou eat bread." Arkwright well deserves to live in honoured remembrance among those ancient master-spirits, who persuaded their roaming companions to exchange the precarious toils of the chase, for the settled comforts of agriculture.

In my recent tour, continued during several months, through the manufacturing districts, I have seen tens of thousands of old, young, and middle-aged of both sexes, many of them too feeble to get their daily bread



take an example from the spinning of cotton—the first operation in delicacy and importance, is that of laying the fibres truly parallel in the spongy slivers, and the next is that of drawing these out into slender spongy cords, called rovings, with the least possible twist; both being perfectly uniform throughout their total length. To execute either of these processes tolerably by a hand-wheel, would require a degree of skill not to be met with in one artisan out of a hundred. But fine yarn could not be made in factory-spinning except by taking these steps, nor was it ever made by machinery till Arkwright's sagacity contrived them. Moderately good yarn may be spun indeed on the *hand-wheel* without any drawings at all, and with even indifferent rovings, because the thread, under the two-fold action of twisting and extension, has a tendency to equalize itself.

The principle of the factory system then is, to substitute mechanical science for hand skill, and the partition of a process into its essential constituents, for the division or graduation of labour among artisans. On the handicraft plan, labour more or less skilled, was usually the most expensive element of production—*Materiam superabat opus*; but on the automatic plan, skilled labour gets progressively superseded, and will, eventually, be replaced by mere overlookers of machines.

By the infirmity of human nature it happens, that the more skilful the workman, the more self-willed and intractable he is apt to become, and, of course, the less fit a component of a mechanical system, in which, by occasional irregularities, he may do great damage to the whole. The grand object therefore of the modern manufacturer is, through the union of capital and

science, to reduce the task of his work-people to the exercise of vigilance and dexterity,—faculties, when concentrated to one process, speedily brought to perfection in the young. In the infancy of mechanical engineering, a machine-factory displayed the division of labour in manifold gradations—the file, the drill, the lathe, having each its different workmen in the order of skill: but the dexterous hands of the filer and driller are now superseded by the planing, the key-groove cutting, and the drilling-machines; and those of the iron and brass turners, by the self-acting slide-lathe. Mr. Anthony Strutt, who conducts the mechanical department of the great cotton factories of Belper and Milford, has so thoroughly departed from the old routine of the schools, that he will employ no man who has learned his craft by regular apprenticeship; but in contempt, as it were, of the division of labour principle, he sets a ploughboy to turn a shaft of perhaps several tons weight, and never has reason to repent his preference, because he infuses into the turning apparatus a precision of action, equal, if not superior, to the skill of the most experienced journeyman.

An eminent mechanic in Manchester told me, that he does not choose to make any steam-engines at present, because with his existing means, he would need to resort to the old principle of the division of labour, so fruitful of jealousies and strikes among workmen; but he intends to prosecute that branch of business whenever he has prepared suitable arrangements on the equalization of labour, or automatic plan. On the graduation system, a man must serve an apprenticeship of many years before his hand and eye become skilled enough for certain mechanical feats;

but on the system of decomposing a process into its constituents, and embodying each part in an automatic machine, a person of common care and capacity may be entrusted with any of the said elementary parts after a short probation, and may be transferred from one to another, on any emergency, at the discretion of the master. Such translations are utterly at variance with the old practice of the division of labour, which fixed one man to shaping the head of a pin, and another to sharpening its point, with most irksome and spirit-wasting uniformity, for a whole life.

It was indeed a subject of regret to observe how frequently the workman's eminence, in any craft, had to be purchased by the sacrifice of his health and comfort. To one unvaried operation, which required unremitting dexterity and diligence, his hand and eye were constantly on the strain, or if they were suffered to swerve from their task for a time, considerable loss ensued, either to the employer, or the operative, according as the work was done by the day or by the piece. But on the equalization plan of self-acting machines, the operative needs to call his faculties only into agreeable exercise; he is seldom harassed with anxiety or fatigue, and may find many leisure moments for either amusement or meditation, without detriment to his master's interests or his own. As his business consists in tending the work of a well regulated mechanism, he can learn it in a short period; and when he transfers his services from one machine to another, he varies his task, and enlarges his views, by thinking on those general combinations which result from his and his companions' labours. Thus, that cramping of the faculties, that narrowing of the mind,

that stunting of the frame, which were ascribed, and not unjustly, by moral writers, to the division of labour, cannot, in common circumstances, occur under the equitable distribution of industry. How superior in vigour and intelligence are the factory mechanics in Lancashire, where the latter system of labour prevails, to the handicraft artisans of London, who, to a great extent, continue slaves to the former! The one set is familiar with almost every physico-mechanical combination, while the other seldom knows anything beyond the pin-head sphere of his daily task.

It is, in fact, the constant aim and tendency of every improvement in machinery to supersede human labour altogether, or to diminish its cost, by substituting the industry of women and children for that of men; or that of ordinary labourers, for trained artisans. In most of the water-twist, or throstle cotton mills, the spinning is entirely managed by females of sixteen years and upwards. The effect of substituting the self-acting mule for the common mule, is to discharge the greater part of the men spinners, and to retain adolescents and children. The proprietor of a factory near Stockport states, in evidence to the commissioners, that by such substitution, he would save 50% a week in wages, in consequence of dispensing with nearly forty male spinners, at about 25s. of wages each. This tendency to employ merely children with watchful eyes and nimble fingers, instead of journeymen of long experience, shows how the scholastic dogma of the division of labour into degrees of skill has been exploded by our enlightened manufacturers.

They are, in truth, much better acquainted with the general economy of the arts, and better qualified to

analyse them into their real principles, than the re-cluse academician can possibly be, who from a few obsolete data, traces out imaginary results, or conjures up difficulties seldom encountered in practice. He may fancy, for example, that in a great establishment, where several hundred people are employed in producing fine goods, much time and expense must be incurred in verifying the quality and quantity of the work done by each individual. But this verification forms an integral step in the train of operations, and therefore constitutes no appreciable part of the cost of the manufactured article. Thus, for example, the reeling of yarn into hanks measures its length; the weighing of a few miscellaneous hanks determines the grist of the whole; and the *taker-in of work* rapidly ascertains its soundness. For examining the quality of the very fine yarns used in lace-making, he is aided by machines which register rapidly the uniformity of its cohesive strength, and the exact volume which one hundred yards of it occupy. The lace-maker again, on his part, verifies the grist of all the thread he purchases, in the necessary act of filling the circular grooves of his tiny bobbins, preparatory to their entering into his machine.

The university man, pre-occupied with theoretical *formulae*, of little practical bearing, is too apt to undervalue the science of the factory, though, with candour and patience, he would find it replete with useful applications of the most beautiful dynamical and statical problems. In physics, too, he would there see many theorems bearing golden fruit, which had been long barren in college ground. The phenomena of heat, in particular, are investigated in their multifarious re-

lations to matter, solid, liquid, and aëriform. The measure of temperature on every scale is familiar to the manufacturer, as well as the distribution of caloric, and its habitudes with different bodies. The production of vapours; the relation of their elastic force to their temperature; the modes of using them as instruments of power, and sources of heat; their most effective condensation; their hygrometric agency; may all be better studied in a week's residence in Lancashire, than in a session of any university in Europe. And as to exact mechanical science, no school can compete with a modern cotton-mill.

When a certain elevation of temperature is made to give pliancy to the fibres of cotton or wool, the philosophical spinner sees the influence of caloric in imparting ductility and elasticity to bodies. The thermometer to indicate the temperature, and the hygrometer the humidity of the air, give him an insight into the constitution of nature unknown to the bulk of mankind. Of the different dilatations of different solids by increments of temperature, he has daily experience in the elongation of the immense systems of steam-pipes which heat his mill apartments, often extending three hundred feet in a straight line. On this scale, the amount of the expansion, and contraction, needs no micrometer to measure it, for it is visible to the eye, and may be determined by a carpenter's rule.

When fire-proof factories of iron and brick were first built, the columns which supported the successive floors, being hollow, were intended to admit steam, and to be the channels of communicating heat to the apartments. It was soon found, however, that the lengthening and shortening of a columnar range eighty

or ninety feet high, by alternations of temperature, equal to  $170^{\circ}$  F., were so considerable, as to impair the stability of the most solid edifice, since metal changes its dimensions by heat with irresistible force. This project of frugality being therefore abandoned, horizontal steam-pipes were suspended near the ceiling, by swinging rods of iron, which terminated at one end in a curved copper tube, for allowing the water of condensation to escape, and possessed of such pliancy as to give free play to the expansion and contraction. Ingenious expedients have been proposed for causing the lengthening of the main pipes to regulate the admission of steam into them, and to exclude it as soon as the temperature of the range had reached the proper pitch. An invention of this kind was made the subject of a patent many years ago, but it never came into general use, on account of certain irregularities in its performance. It was found very difficult so to adjust the lever mechanism of the valve, as to prevent its intercepting the flow of the steam whenever a certain portion of the long pipe was heated, long before the steam had reached the remoter end. Hence its uniform distribution was rendered precarious. Mill engineers have therefore satisfied themselves with insulating the steam-pipe ramifications from the building, leaving the circulation of the steam to be tempered by an ordinary stop-cock. The instrument, for which I have obtained a patent, under the name of the heat-governor, or thermostat, would furnish the factory proprietors with a self-acting means of regulating the temperature of their apartments, and of promoting their ventilation.

In an analysis of manufacturing industry, the general functions of machines, and the effects of their im-

provements, ought to be well considered. Machines are of three kinds:—

1. Machines concerned in the production of power.
2. Machines concerned in the transmission and regulation of power.
3. Machines concerned in the application of power, to modify the various forms of matter into objects of commerce.

I. Machines engaged in producing power operate by counteracting gravity, inertia, or cohesion. The steam engine, by the expansive agency of vapour, raises and depresses its ponderous piston, and thereby moves its massive beams and gearing. The hydraulic wheel produces similar effects by the natural flow or fall of water from a higher to a lower level; and the windmill by the currents of the atmosphere. Blasting of rocks, in mining, exhibits elastic power overcoming cohesion.

II. The machines engaged in transmitting and regulating power are, toothed wheels, fly wheels of various kinds, valve governors, shafts, and other gearing of mills.

III. The machines engaged in applying power to modify the forms of matter appear, at first sight, to be so multifarious as to set systematic arrangement at defiance. An outline of their connexions and dependencies has been attempted in the next chapter.

The philosophy of manufactures is well displayed in the economy of power. The value of steam-impelled labour may be inferred from the following statement of facts, communicated to me by an eminent engineer, educated in the school of Bolton and Watt:—A manufacturer in Manchester works a 60-horse Bolton and Watt's steam-engine, at a power of 120 horses during the

day, and 60 horses during the night; thus extorting from it an impelling force three times greater than he contracted or paid for. One *steam* horse-power is equivalent to 33,000 pounds avoirdupois, raised one foot high per minute; but an *animal* horse-power is equivalent to only 22,000 pounds raised one foot high per minute, or, in other terms, to drag a canal boat 220 feet per minute, with a force of 100 pounds acting on a spring: therefore a steam horse-power is equivalent in working efficiency to one living horse, and one-half the labour of another. But a horse can work at its full efficiency only eight hours out of the twenty-four, whereas a steam-engine needs no period of repose; and therefore, to make the animal power equal to the physical power, a relay of  $1\frac{1}{2}$  fresh horses must be found three times in the twenty-four hours, which amounts to  $4\frac{1}{2}$  horses daily. Hence, a common 60-horse steam-engine does the work of  $4\frac{1}{2}$  times 60 horses, or of 270 horses. But the above 60-horse steam-engine does one-half more work in 24 hours, or that of 405 living horses! The keep of a horse cannot be estimated at less than 1*s.* 2*d.* per day; and therefore that of 405 horses would be about 24*l.* daily, or 7500*l.* sterling in a year of 313 days. As 80 pounds of coals, or one bushel, will produce steam equivalent to the power of one horse in a steam-engine during eight hours' work, sixty bushels, worth about 30*s.* at Manchester, will maintain a 60-horse engine in fuel during eight effective hours, and 200 bushels, worth 100*s.*, the above hard-worked engine, during twenty-four hours. Hence, the expense per annum is 1565*l.* sterling, being little more than one-fifth of that of living horses. As to prime cost and superintendence, the

animal power would be greatly more expensive than the steam power. There are many engines made by Bolton and Watt, forty years ago, which have continued in constant work all that time with very slight repairs. What a multitude of valuable horses would have been worn out in doing the service of these machines! and what a vast quantity of grain would they have consumed! Had British industry not been aided, by Watt's invention, it must have gone on with a retarding pace, in consequence of the increasing cost of motive power, and would, long ere now, have experienced, in the price of horses, and scarcity of waterfalls, an insurmountable barrier to further advancement, could horses, even at the low prices to which their rival, steam, has kept them, be employed to drive a cotton mill at the present day, they would devour all the profits of the manufacturer.

Steam-engines furnish the means not only of their support but of their multiplication. They create a vast demand for fuel; and, while they lend their powerful arms to drain the pits and to raise the coals, they call into employment multitudes of miners, engineers, ship-builders, and sailors, and cause the construction of canals and railways: and, while they enable these rich fields of industry to be cultivated to the utmost, they leave thousands of fine arable fields free for the production of food to man, which must have been otherwise allotted to the food of horses. Steam-engines moreover, by the cheapness and steadiness of their action, fabricate cheap goods, and procure in their exchange a liberal supply of the necessaries and comforts of life, produced in foreign lands.

Improvements in machinery have a three-fold bearing:—

1st. They make it possible to fabricate some articles which, but for them, could not be fabricated at all.

2d. They enable an operative to turn out a greater quantity of work than he could before,—time, labour, and quality of work remaining constant.

3d. They effect a substitution of labour comparatively unskilled, for that which is more skilled.

The introduction of new machines into any manufacture, with the effect of superseding hand labour, is tempered by the system of patents, which maintains them for a certain time at a monopoly price, and thereby obstructs their rapid multiplication. Did we admit the principles on which the use of particular self-acting mechanisms is objected to by workmen, we should not be able, in any case, to define the limits of their application. Had parliament acted on such principles sixty years ago, none of our manufactures could have attained to their present state of profitable employment to either masters or men. The immediate causes of their vast augmentation may be ascribed, under the blessing of Providence, to the general spirit of industry and enterprize among a free and an enlightened people, left to the unrestrained exercise of their talents in the employment of a vast capital, pushing to the utmost the principle of the analysis of labour, summoning to their service all the resources of scientific research and mechanical ingenuity; and finally, availing themselves of all the benefits to be derived from visiting foreign countries, not only in order to form new and confirm old commercial connexions, but to obtain an intimate knowledge of the wants, the tastes, the habits, the dis-

coveries and improvements, the productions, and fabrics of other civilized nations. Thus we bring home facts and suggestions; thus we perfect our old establishments, and add new branches to our domestic stock; opening, at the same time, new markets for the sale of our manufacturing and commercial industry, and qualifying ourselves for supplying them in the best and most economical manner. By these means alone, and, above all, by the effect of machinery in improving the quality, and cheapening the fabrication of our various articles of export, notwithstanding an immense load of taxes, and a higher price of grain, our commerce and manufactures have also increased in such a degree, as to surpass the most sanguine calculations of the ablest political economists who have speculated on the prospects of mankind. We should never cease to bear in mind, that we are surrounded by powerful nations, composed of a people equally industrious, and more sober than ourselves, who, released from the turmoil of war, are intent on cultivating the productive arts of peace, and of pushing their commerce and navigation; whose eagerness of competition is stimulated by the view of the rich prizes which we have already won.

The attempts continually made to carry our implements and machines into foreign countries, and to tempt our artisans to settle and superintend them there, evince the high value set by other nations on our mechanical substitutes for hand labour; and as they cannot be directly counteracted, they should be rendered, as far as possible, unavailing, by introducing such successive improvements at home as may always keep us foremost in the career of construction. It would be therefore no less disastrous to the operative, than to the capi-

talist, were any extraneous obstacles thrown in their way, since any good machine suppressed, or rejected, in this country, would infallibly be received with open arms by some of our neighbours, and most readily by our mechanical rivals in France, Belgium, Germany, and the United States.

Mill architecture is a science of recent origin, which even at this day is little understood beyond the factory precincts. It had been ably begun by Mr. Watt, but, till it fell into the hands of Messrs. Fairbairn and Lillie, the eminent engineers of Manchester, it was too subject to the whims of the several individuals, often utterly ignorant of statics or dynamics, or the laws of equilibrium and impulse, who had capital to lay out in building a mill. Each had his own set of caprices and prejudices, which he sought to embody in his edifice, little aware how much the different orders of machines depended for the productiveness and precision of their performance, on the right magnitudes, proportions, and adjustments of the main-shafting and wheel-geering. These are, in fact, the grand nerves and arteries which transmit vitality and volition, so to speak, with due steadiness, delicacy, and speed, to the automatic organs. Hence, if they be ill-made or ill-distributed, nothing can go well, as happens to a man labouring under aneurismal and nervous affections.

About three years ago, the above-named engineers dissolved a partnership celebrated over the world; since which time each has expanded his energies, and distinguished himself in a peculiar line of work. I shall have occasion hereafter to describe several of Mr. Lillie's excellent mechanical constructions. Mr.

Fairbairn has entered largely into the line of a factory architect, for which his three-fold great workshops are admirably adapted. The capitalist has merely to state the extent of his resources, the nature of his manufacture, its intended site, and facilities of position in reference to water or coal, when he will be furnished with designs, estimates, and offers on the most economical terms, consistent with excellence, according to a plan, combining elegance of external aspect, with solidity, convenience, and refinement in the internal structure. As engineer he becomes responsible for the masonry, carpentry, and other work of the building, for the erection of a sufficient power, whether of a steam-engine or water-wheel, to drive every machine it is to contain, and for the mounting of all the shafts and great wheels by which the power of the first mover is distributed. The frontispiece of this volume exhibits a perspective view of a magnificent factory, lately finished by Mr. Fairbairn, and now at work under its spirited proprietor, Mr. Orrell. It is beautifully situated in the environs of Stockport, on a branch of the Mersey, the great river feeder of the cotton trade of England. In beauty of architectural design, it will yield to no analogous edifice, and may, indeed, bear a comparison in respect of grandeur, elegance, and simplicity, with many aristocratic mansions. The length of the apartments in each floor of the body of the house is three hundred feet, the breadth fifty feet, and the height of each floor twelve feet. Each window consists of two casements, extending from its top to its sill, one of which, nearly as large as a common window, may be thrown entirely open for admitting fresh air, independent of the mechanical ventilation. I have

been favoured, through the liberality of the architect and proprietor of this pattern structure, with an analytical section and ground plan of it, by which I shall be enabled, in the treatise on the cotton trade, to place before my readers a view of the whole anatomy of the mill, in the following order.

1. Its two-fold heart, or twin steam-engines, one of which makes its maximum effort, while the other makes its minimum, to secure perfect equability of impulsion through all the ramifications of its shafts, and to prevent arterial throbbing or tremor, formerly so common, and so injurious to the work of delicate machines.

2. The great bevel wheel-geering, which transmits the power of the engine in rectangular directions, either transversely or vertically, and with any modification of speed.

3. The horizontal and upright shafts, with their several pulleys.

4. The distribution of the straps, or belts, that convey the power from these revolving shafts and pulleys.

5. The respective positions of the various productive organs in their respective floors, such as the preparation machines, throstles, mules, power-looms, dressing machines, warping mills, &c. &c.

The recent innovations in proportioning the sizes, regulating the connections, and adjusting the movements of the system of shaft-geering, form a fine feature in the philosophy of manufactures. Thus not only an improvement has been made in the regularity of impulsion, but a considerable increase of power from the same prime-mover has been obtained; amounting, in some cases, of old mills remounted by Messrs. Fair-

bairn and Lillie, to fully twenty per cent. The durability of shafts so exquisitely turned and polished, is another great advantage. The spinning factory of Messrs. Ashworth, at Egerton, which has been at work for several years, exhibits an elegant pattern of the engineering just described: for it has some subordinate shafts, hardly thicker than the human wrist, which convey the power of ten horses, and revolve with great speed, without the slightest noise or vibration. The prime-mover of the whole is a gigantic water-wheel of sixty feet diameter, and one hundred horses' power. I have frequently been at a loss, in walking through several of the millwright factories, to know whether the polished shafts that drive the automatic lathes and planing machines, were at rest or in motion, so truly and silently did they revolve.

The method of increased velocities in the driving arms or shafts of factories is, undoubtedly, one of the most remarkable improvements in practical dynamics. It diminishes greatly the inertia of the mass to be moved, by giving to much lighter shafts and wheels the same momentum, and it permits the pulleys or drums, which immediately impel the machines by straps, to be reduced to a size much nearer to that of the steam pulleys fixed on the main axes of these machines. About thirty years ago the velocities of the main shafts, proceeding from the moving power, whether of steam or water, amounted to no more than from thirty to forty revolutions per minute, and of the smaller and remoter shafts, to only forty or fifty. At the same period the drums were heavy tubs, and from thirty to upwards of sixty inches in diameter. This improved system is under deep obligations for its



actual state of perfection to the above-named engineers, though it had commenced, as we have stated, before their time. In the mills mounted by these gentlemen it is interesting to see slender shafts, like small sinewy arms, rapidly transmitting vast power through all the ramifications of a great factory.

The following details will place this matter in the clearest light:—A mill propelled by a steam-engine of fifty horses' power was formerly geared with shafts, having an average transverse section of thirty-six square inches, or varying in size from four to eight inches square. An engine of like power at the present day will, in consequence of the increased velocities above described, work with cylindrical shafts not exceeding five and a half, and often only three inches in diameter; possessing therefore an average area of only fifteen square inches, instead of thirty-six. The horizontal shafts that run under the ceilings of the different working rooms are two inches, and seldom exceed two and a quarter in diameter. Hence the mass of gearing has been reduced fully one-half. But the shafts now make from one hundred and twenty, to one hundred and fifty revolutions in a minute, and, occasionally, as where throstles are turned, so many as two hundred in the same time. Thus we see the requisite momentum is gained with a light shaft, while the friction is proportionally diminished, and the driving drum revolves with a velocity in accordance with the accelerated pace of the modern machines. The several speeds will be given in discussing their respective subjects.

The philosophy of manufactures investigates, in the next place, the most economical and energetic modes

of applying the motive force to the various working organs; the carding-engines, the drawing-heads, the roving-frames, the throstles, the mules, the power-looms, the dressing-machines, &c.

The British capitalist is vigorously seconded by the British engineer, and need not, like the Continental adventurer, leave his funds long dormant, after an opportunity of placing them profitably in factory enterprise occurs. One mill-wright establishment in Manchester turns out from three hundred to four hundred yards of shaft-gearing every week, finely finished, at a very moderate price, because almost every tool is now more or less automatic, and performs its work more cheaply and with greater precision than the hand could possibly do. Where many counterparts or similar pieces enter into spinning apparatus, they are all made so perfectly identical in form and size, by the self-acting tools, such as the planing and key-groove cutting machines, that any one of them will at once fit into the position of any of its fellows, in the general frame.

For these and other admirable automatic instruments, which have so greatly facilitated the construction and repair of factory machines, and which are to be found at present in all our considerable cotton mills, this country is under the greatest obligations to Messrs. Sharp, Roberts, and Co. of Manchester. By such aids, fine-cotton spinners are enabled to mount their mules and the subservient frames within their own premises, with peculiarities of construction suited to their style of work; and many of them re-model more or less the apparatus made in the machine-shops. Thus the bobbin and fly-frames of Messrs. Cocker and Higgins, so justly admired, require occasionally to

be modified in certain minutiae, essential to fine work, before being used by certain manufacturers. It is this skill in machine mounting or adjusting, combined with tact in spinning, which gives to our factories not merely their existing superiority over foreign rivalry, but the best security for its permanence. Indeed, the concentration of mechanical talent and activity in the districts of Manchester and Leeds is indescribable by the pen, and must be studied confidentially behind the scenes, in order to be duly understood or appreciated.

The following anecdote will illustrate this position. A manufacturer at Stockport, whose name I shall suppress, being, not long ago, about to mount two hundred power-looms in his mill, fancied he might save a pound sterling in the price of each, by having them made by a neighbour machine-maker, instead of obtaining them from Messrs. Sharp and Roberts, in Manchester, the principal constructors of power-looms. In order to give his fabricator every chance of success, the economist surreptitiously procured iron patterns cast from one of the looms of that company, which in its perfect state (see the engraving at the end of this volume) costs no more than £9. 15s. His two hundred looms were accordingly constructed at Stockport, supposed to be fac-similes of those regularly made in Manchester, and they were set to work. Hardly a day passed, however, without one part or another breaking down, insomuch that the crank or tappet-wheels had to be replaced three times, in almost every loom, in the course of twelve months. The fabric of the cloth was also indifferent. The proprietor, perplexed beyond measure, inquired of a neighbour

who worked similar power-looms, made by the Manchester mechanicians, whether *his* wheels likewise went to pieces every other day, and learned to his mortification, that not one of them had broken in the course of working, but that the four or five spare ones, originally sent from Manchester along with his two hundred and thirty-six power-looms, were unused and quite at his service. The old proverb of ‘penny wise and pound foolish’ never had a better illustration. His weaving factory had been most irregular and unproductive, while that of his neighbour had been uniformly prosperous. Being now heartily sick and ashamed of his fac-simile copies, he took measures in secret to have them replaced, as soon as possible, by Sharp and Roberts’s substantial machines.

The astonishing expedition with which a great Cotton Factory, comprehending spinning and weaving, can be erected in Lancashire, arises from the vast collections of patterns of every variety, from those of gigantic steam-engines, water-wheels, iron-girders, and joists, down to the smallest member of a throstle or loom, in possession of the engineers, mill-wrights, and machine-makers. In the course of last year, Mr. Fairbairn equipped water-wheels equivalent to 700 horses’ power, and steam-engines to 400 horses’ power, from his engineer factory alone, independent of his mill-wright and steam-boiler establishment. Hence, whenever capital comes forward to take advantage of an improved demand for goods, the means of fructifying it are provided with such rapidity, that it may realize its own amount in profit, ere an analogous factory could be set a-going in France, Belgium, or Germany.

The facilities resulting from the employment of self-acting tools have not only improved the accuracy, and accelerated the construction of the machinery of a mill, but have also lowered its cost and increased its mobility, in a remarkable degree. At present, a throstle frame made in the best manner may be had complete at the rate of 9*s.* 6*d.* per spindle; and a self-actor at about 8*s.* per spindle, including the patent licence for the latter. The spindles in cotton factories move with so little friction that one horse power drives 500 on the fine hand-mule, 300 on the self-actor mule, and 180 on the throstle; which power includes all the subsidiary preparation machines, as carding, roving, &c. A power of three horses is adequate to drive 30 large looms with their dressing machine.

The fine bobbin and fly-roving frame, is now so greatly improved, that it can do a certain part of the work formerly done by the stretching mule; and performs as much for 9*s.* as the other did for 50*s.*

The dressing machine does at present 200 pieces of thirty yards each in a week, = 6000 yards, and costs in wages to the dresser 50*s.* This branch of the trade having in consequence of the high wages been, like the mule spinning, continually disturbed by unions and strikes, has led to the invention of a self-acting machine which will dress at least 6000 yards of warp in two days, under the superintendence of a labourer at 3*s.* a-day; that is, at a cost in wages of 6*s.* This mechanism is at the same time greatly simpler and cheaper than the former, and will soon come into general use for coarse calicocs. It affords an instructive warning to workmen to beware of strikes, by proving how surely science, at the call of capital,

will defeat every unjustifiable union which the labourers may form.

It is one of the most important truths resulting from the analysis of manufacturing industry, that unions are conspiracies of workmen against the interests of their own order, and never fail to end in the suicide of the body corporate which forms them; an event the more speedy, the more coercive or the better organized the union is. The very name of union makes capital restive, and puts ingenuity on the alert to defeat its objects. When the stream of labour is suffered to glide on quietly within its banks, all goes well; when forcibly dammed up, it becomes unprofitably stagnant for a time, and then brings on a disastrous inundation. Were it not for unions, the vicissitudes of employment, and the substitution of automatic for hand work, would seldom be so abrupt as to distress the operative.\*

Some may imagine that the present work, which purposes to give a minute analysis and description of the several processes of manufacture, may prove injurious to the trade of this country, by putting foreigners in possession of much useful knowledge, now hardly within their reach. To this I reply, that knowledge is available just in proportion to the capacity and means of the persons who acquire it. Every invention and improvement relative to cotton fabrics is primarily attracted to Manchester as the surest and most productive scene of its development, where it can be most profitable to the inventor, because most profitable to the trade concentrated there. Lancashire is the fertile and well-laboured soil in which the seed of factory

\* The full discussion of this topic belongs to Book III.

knowledge will bring forth fruit one hundred fold, whereas abroad it can yield little more than a tenfold return. However well informed the mill proprietors of Great Britain may be, and they unquestionably may bear a comparison in talent as in wealth with the landed aristocracy in any part of the world, still they may profit extremely by the methodical study of the elements of their prosperity. Many of the machines at present employed by them involve the most elegant applications of both physical and mechanical science; such indeed as if duly studied would enable them to understand the operative part of their business as clearly as the commercial, and thus protect them from those hazardous innovations which crafty projectors are perpetually pressing upon their adoption. Prodigious sums are wastefully expended every year by gentlemen manufacturers in this way, which would be saved by a more thorough acquaintance with those principles of science and art which I shall endeavour to expound.

Several individuals who have embarked vast fortunes in factories are to a very great extent the victims at least, if not the dupes, of scheming managers, who are ever ready to display their perverse ingenuity by the substitution of some intricate trap, for a simpler but less showy mechanism. I have known not a few cases, where a complete system of good machines, capable of doing excellent work, has been capriciously turned out of a cotton factory and replaced by another of greater expense, but of less productive powers, and less suited to the style of work, than the old one if skilfully managed. These substitutions are continual in many establishments. They interfere most essentially, and often unnecessarily, with the going of the

mill, and are referrible almost always to injudicious choice at first, and capricious alterations afterwards,—circumstances over which the proprietor, from ignorance of the structure of a good machine, cannot always venture to exercise the proper control. There are no doubt many mill-managers perfectly fitted by judgment, knowledge, and integrity to second the sound commercial views of the mill-owner, and to advance the business with a profitable career. These practical men form the soul of our factory system. But with a wrong-headed, plausible manager, the proprietor is sure to be led such a mechanical dance as will bewilder him completely, unless he has acquired a clear insight into the *arcana* of the business by deliberate study of the composition and performance of each machine in his factory. It may be supposed that this species of education can be most easily acquired in the midst of the machinery itself. But this is a mistake which experience speedily proves.

There exists in most cotton-spinning factories a beautiful piece of mechanism called the bobbin and fly frame, regulated by a principle of self-acting equations, which would do honour to the genius of Brunel. In venturing to affirm that very few mill-owners understand the structure of this machine, I do not draw the inference presumptuously from the difficulty which I myself encountered in comprehending the automatic adjustments of its parts; but from meeting with several masters of the Manchester mills who were incompetent to explain the train of its motions, however obligingly they undertook the task. In fact one scientific gentleman, a complete master of that mechanism and of every other used in the trade, who kindly acted on

many occasions as Mentor in my factory researches, assured me that his father, a very talented cotton-spinner, as the country well knows, never can retain a clear comprehension of certain differential adjustments in the above machine for a week after it has been explained to him. Some of its movements being necessarily inclosed, and of a curious nature, can be best studied in an analytical drawing, where the whole concatenated motions are brought at once under the student's eye. Such complex mechanisms, indeed, like the topography of an irregular city, are most readily comprehended by inspection of a plan, in which the mutual bearings and connexions of the parts are analytically shown. The representations which I shall have the honour of presenting to the public were made by a talented draughtsman, who accompanied and lived with me in the factory districts, and they were submitted to some of the most eminent engineers and machine-makers of Manchester, from whom they received unqualified praise for accuracy as well as elegance of execution.

I shall conclude this general view by stating, that the moving power, besides performing its proper factory tasks of carding, roving, spinning, weaving, &c., does a vast deal of miscellaneous drudgery. It raises the coals from their bin in the boiler-yard by a sloping series of buckets, like those of a dredging machine for deepening rivers, and delivers them on an elevated railway platform into a waggon—through the drop-bottom of which they are duly distributed among the range of hoppers attached to Stanley's ingenious furnace-feeding machines, and are thereby strewn into the fires in proportion to the demand for steam to work

or warm the mill. In this way the fire-man is entirely freed from muscular effort, so that he can tend with ease many great steam-boilers, and is not liable through ignorance or negligence to mismanage the heat, or dissipate the fuel in such black clouds as lower over a London brewery. It is no uncommon thing in Manchester to see engine-boilers equivalent to the force of from 200 to 300 horses generating their steam without any sensible smoke.

But there is another office more truly menial assigned to the engine, that of transporting any of the work-people upwards or downwards to any floor of the factory, to which their business may call them at any time, and this with equal celerity and safety. To ascend and descend rapidly through several flights of stairs is no trifling source of fatigue, as domestic servants in some fashionable houses well know. Masters of mills, with the twofold motive of benevolence and economy, have long ago taken measures to supersede this painful exertion, by the construction of moveable platforms, inclosed in upright tunnels placed in convenient parts of their many-storied buildings. This apparatus is called a hoist or a teagle, and is usually of such size and stability, as to allow half a dozen of persons, old and young, to travel at once from any one floor to any other. The motion is perfectly smooth and agreeable, as I have often experienced; and is so entirely under control, as to cease at any desired instant opposite to any of the issue-doors in the side of the tunnel.

The muscular force expended in mounting stairs was made the subject of experiment by M. Coulomb. Amontons had previously found that an active man, weighing 150 lbs. English, was completely ex-

hausted in ascending, by steps, sixty-five feet in thirty-two seconds. The full work of a man is obtained by his going up stairs at the rate of forty-five feet in one minute. A man weighing 160 lbs. can ascend by stairs three feet per second for a space of fifteen or twenty seconds; and if he be supposed going up stairs for a day, he actually raises 450 lbs. to the height of 3281 feet; or 1,476,450 lbs. one foot high. If the day be reckoned at ten hours, or 600 minutes, he will raise 2460 lbs. one foot high in a minute, which is only one-thirteenth of Watt's estimate of a horse's power = 32000 lbs. raised one foot high per minute. With a winch a man does, according to Coulomb, only five-eighths as much work as in going up stairs. If the above observations be nearly correct, they prove the expenditure of power in ascending stairs to be great. Coulomb says that this mode of action is the most advantageous for the muscular force of man, though he rates its amount at little more than one-half of Smeaton's estimate of an English labourer's force.

The mechanism of the teagle will be understood by the following description and drawing taken from one of the most improved forms made by Frost of Derby, who in concert with the late William Strutt, Esq., had the merit of inventing this very elegant automatic machine.

The teagle (tackle?) or hoist, consists of three principal parts.

1. The perpendicular shaft or pit, having a horizontal section, of about five or six feet square, placed in the most convenient part of the building, and extending from the ground-floor to the top story.

2. The ascending and descending platform, sus-

ended by ropes from pulleys, and moved up and down by machinery. It is a strong frame-work of timber, about six feet high, boxed up on three sides with deals, leaving the front side open, in correspondence with a series of doors on the several floors of the factory. The power required for hoisting is moderated by over-balancing the platform with two counter-weights, together about a hundred weight heavier than itself, which ascend and descend equably with the descent and ascent of the platform; and which, as well as the platform, are suspended by ropes from the opposite sides of the shaft to secure a steady vertical motion. Two large planks are fixed upright upon the opposite walls of the shaft, as guides to the platform, and two smaller ones as guides to the counter-weights, the latter being sunk groovewise into the building.

3. The third part of the teagle is the machinery capable of being set in train with the moving power.

Fig. 1 shows a longitudinal view of the working gear, and a section of the pit with the platform raised to the top story, opposite the door of the uppermost floor. Fig. 2 is a plan of the whole with the platform descending. Fig. 3 is a cross section through a curious part of the mechanism.

I shall give first a popular explanation of the principle on which the hoist operates.

Every observant visiter of a factory must have noticed that the endless strap or belt which descends from the driving shaft to the steam pulley on the end of a carding, spinning, or weaving organ, (see the loom-factory view at the end of the volume,) sometimes has its two pieces running parallel to each other, as in that view, and sometimes has them crossed

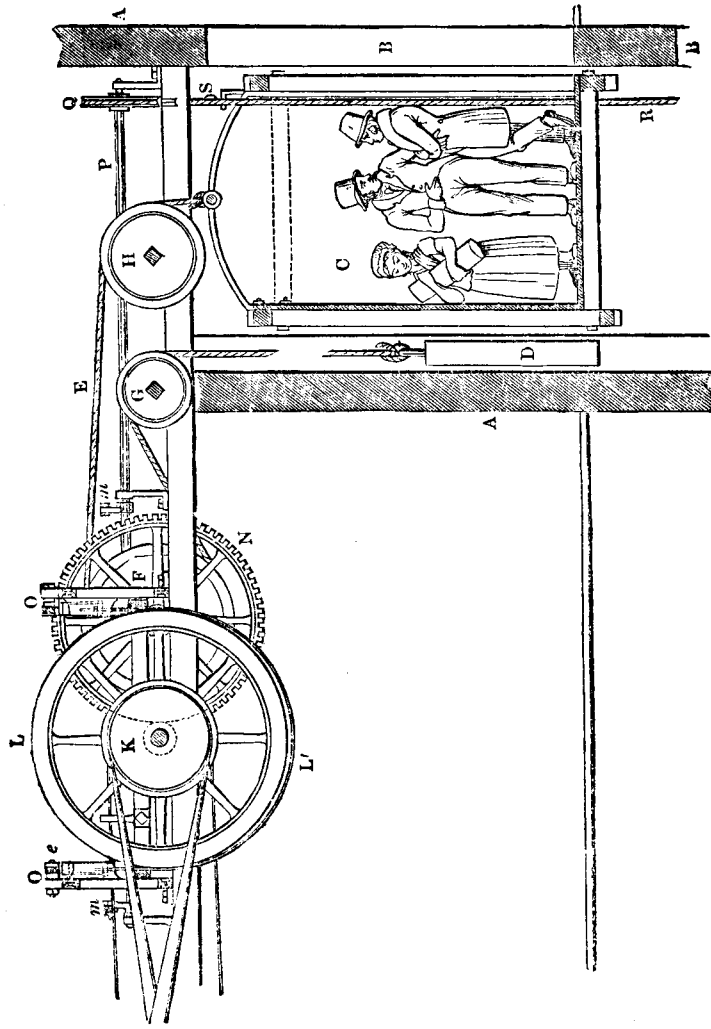
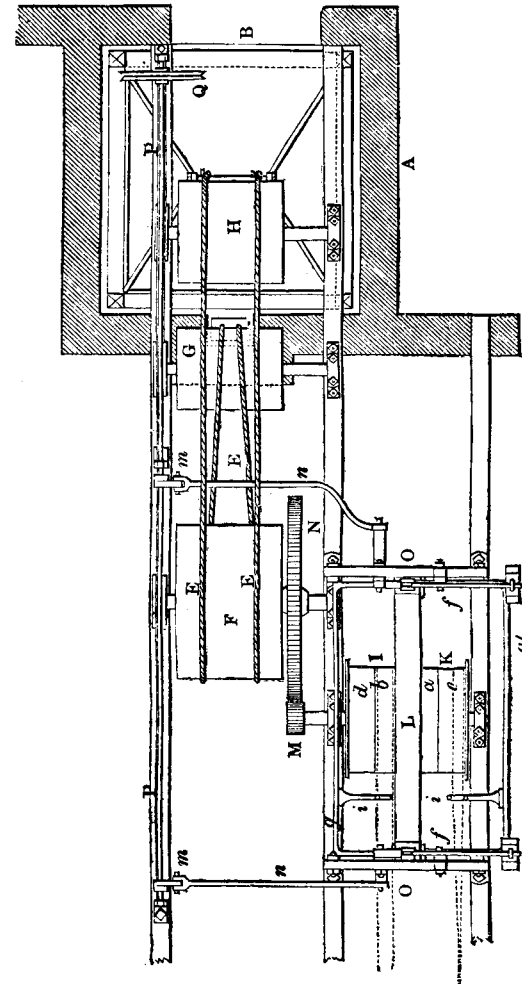

Fig. 1.—The Teagle.



Horizontal Section, or Plan.

Fig. 2.—The Teagle.

over each other. The first arrangement, called the open strap, communicates motion in the one direction, while the other arrangement communicates motion in the opposite direction. Suppose now, that there is a fast pulley on the axis of any machine, and close to it, on either side, a similar pulley loose on the same axis; of which one is driven by an open strap, and the other by a crossed or close one. If the one strap be shifted upon the fast pulley, it will drive the machine in one direction, but if the other strap be shifted upon it, it will drive the machine in the opposite direction; that is, the machine according as it is driven by the open or close strap may be made to work upwards or downwards at pleasure, as in raising or lowering weights, &c.

When both belts are shifted upon the loose pulleys, the machine has no hold of the load, and would therefore allow it to fall by the influence of gravity, were there not some restraining power. This restraint is exercised by a *brake*, which presses strongly on the circumference of a wheel in train with the machinery, and fixes the whole by a force of friction proportional to the weight acting on the brake. Now, to move the load up or down, the brake must be removed at the same instant that the appropriate strap is shifted upon the fast pulley of the machine. The same contrivance which replaces the strap on the loose pulley, replaces the pressure of the brake on the friction-wheel.

Before describing minutely the structure of the hoist, it is proper to mention that all movements produced by straps ought to be pretty rapid, since, when slow, they are apt to permit a slipping of the bands on the surface of the driving-drums or pulleys. As, there-

fore, in this way, the pulley-shaft of the teagle would require too great a speed, for being connected directly with the hoisting rope, it transfers its motion, by means of a pinion and a wheel, to a second shaft, which travels at such a rate as to cause the platform to rise or fall through two feet in the second.

A A (figs. 1 and 2) are the opposite walls of the vertical tunnel, which support at top the beams of the machinery. B is one of the doors leading to an apartment of the mill: C is the platform or hoisting box: D, one of the counterweights, both connected to the ends of the two ropes E E, which run in grooves over the hoisting pulley F, and thence over the guide pulleys G and H. The counterweight D cannot be seen in its proper place in this figure, but has its cord discontinuous, to show the shortening, in order to bring the weight into sight. When the platform is at the top, its counterweight must obviously be at the bottom of the tunnel.

F and K are the steam or impelling pulleys, frequently called riggers (outriggers? as they stand out from the side of the machine, like outrigger-sails in a ship) by engineers. They are moved by two straps proceeding from the principal turning-shaft in that part of the factory. Instead of having one fast pulley common to both straps, as mentioned, for simplicity sake, in our general description, two are used in this teagle, and are to be seen distinctly at *a b*, in the horizontal plan (fig. 2), though concealed in the view (fig. 1), by the wheels at K and F.

The first of these, near K, is for the crossed, and the second, near I, is for the open strap. The adjoining loose pulleys *c*, and *d*, have double the breadth of the fast ones, in order that both straps may have room to



run on their loose pulleys at the same time, so that by shifting them both to the right or to the left, only the one of them will run on the fast pulley, while the other will move upon the spare half of the loose pulley. L is the large *brake* wheel, against the under semi-circumference of which the leather belt L' may be made to press, by means presently to be explained. The dotted little circle at K (fig. 1), shows the form of a small pinion M (fig. 2), which is placed on the other end of the axis of the brake, and works in the teeth of the wheel N, so as to drive it round, and thereby to turn the hoisting pulley F. O O are two iron uprights standing upon the beams which support the bearings of the above-mentioned shafts. In fig. 3, an end view is shown of such an upright frame, or a cross section

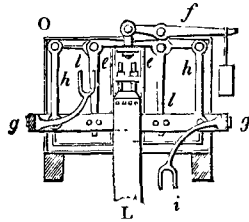

through the beams. One use of these frames is to guide the brake-belt L' in moving up and down for giving friction to, or removing it from, the brake-wheel L. The ends of that belt consist of two pieces of strong leather sewed together, and rivetted to two screw bolts (seen in the middle of fig. 3), which may be attached to two bars of iron *ee*, sliding between flanges on the frames O O, figs. 1 and 2. With the top ends of these slide-pieces *ee*, are connected the levers *ff* (of which one is seen in fig. 3, and both in fig. 2), carrying weights for lifting up the belts

against the brake-wheel, when the machine is out of gear: *gg* is a square iron frame suspended by two rods *hh* on each of the large wooden frames O O. This iron frame, to which are fixed the guides *ii* for moving the straps, may therefore be shifted to the right or left, in order to produce the reversals of motion required. At the same time, however, that they are moved in one of these directions, the frame *gg* presses the two crank levers *ll*, and acts, of course, upon the slide-pieces *ee* which hold the brake-strap, and by depressing it, set the brake-wheel free. By bringing back the swinging frame *gg* into its first position, the levers *ll* cease to press upon the slide-pieces *ee*, so that the weights of the levers *ff* are again able to draw down and detach the brake L'.

It is proper now to state how a person ascending on the platform may push the frame *ee* into a position suitable to his purpose, and may keep it in that position.

P is a slender shaft, upon which there is a rope pulley Q, directly over the middle part of the tunnel, and in the line, in which the endless rope R (fig. 1) goes through the floor of the platform down to the bottom of the pit, in order to pass under a tightening pulley. On the same slender shaft are two arms *mm*, united, by two connecting rods *nn*, to the swinging frame *ee*. By pulling one of the ropes R at any part of its length to which the platform may have arrived, the shaft P will be made to turn round through an arc of 90 degrees, whereby the projecting arms *mm* will be brought into a straight line with the connecting rods, which move the frame *ee* (fig. 3), and thus cause the performance of the already-described move-

ments. The position of the arms  $m m$ , and the connecting rods  $n n$  (shown in fig. 2), in one line will prevent the frame  $e e$  from moving out of the posture it was brought into, till by pulling at the other rope R, the shaft P revolves back again through 90 degrees, and restores its arms  $m m$  to the perpendicular direction.

At a certain point of the top and bottom part of the rope R R are affixed balls, which strike against two rings fixed to the platform, when this has arrived either at its uppermost or undermost position. By these means the platform pulls the rope R and sets itself at rest, so as to prevent every possible accident. When it is required to stop at any intermediate point, the person ascending or descending pulls one of the ropes, marked in the factory teagle with A and D (ascend and descend), and which he learns to do with such nicety that he very seldom errs more than an inch or two in planting the bottom of the platform on a level with the desired spot.

The ropes R R require to be pulled through a space of from twelve to fifteen inches before they produce the required change of motion; and hence they cannot be affected by any casual twitch.

## CHAPTER II.

### *Arrangement and Connexion of Manufactures.*

THE object of manufactures is to modify the productions of nature into articles of necessity, convenience, or luxury, by the most economical and unerring means. They have all three principles of action, or three organic systems; the mechanical, the moral, and the commercial, which may not unaptly be compared to the muscular, the nervous, and the sanguiferous systems of an animal. They have also three interests to subserve, that of the operative, the master, and the state, and must seek their perfection in the due development and administration of each. The mechanical being should always be subordinated to the moral constitution, and both should co-operate to the commercial efficiency. Three distinct powers concur to their vitality,—labour, science, capital; the first destined to move, the second to direct, and the third to sustain. When the whole are in harmony, they form a body qualified to discharge its manifold functions by an intrinsic self-governing agency, like those of organic life.

Manufactures are divisible into two great classes, according as they change the external form, or the internal constitution of their raw material. Hence the distinction of mechanical and chemical arts. Each class may be subdivided into three families, according

as it operates on mineral, vegetable, or animal substances, thus presenting to the student three orders of manufactures, which possess many interesting natural affinities.

Iron will afford the means of illustrating these relations. The ore of the metal is detected and valued by chemical research; but it is dug, and brought to the market, by mechanical agency. The chemist conducts the process of smelting it into cast iron, as well as the conversion of the crude metal into malleable iron and steel, aided by the ministry of the engineer. For the purposes of art, iron is deprived of its metallic state, and acquires many new forms and qualities, by new combinations of its elementary particles. Its various oxides, sulphurets, salts, &c., therefore belong to chemical manufactures. The mechanical group comprehends the operations of the foundry, the forge, the rolling-mill, the slitting-mill, the flattening-mill, &c.

The general classification of the mechanical manufactures may be made either in the order of their respective subjects, as these are arranged by the natural historian, in the mineral, vegetable, and animal kingdoms, or according to the nature of the mechanical and physical actions exercised on these subjects. On the former plan, analogous arts would often be necessarily disjoined, in consequence of the disjoined origin of their materials, however similar their principles and processes might be. Thus the woollen and cotton manufactures, though closely allied, would need to be separately considered under the two distinct departments of the animal and vegetable world. The true philosophical principle of classifying the mechanical manufactures, is to arrange them in the order of the general

properties of matter, which it is their object to modify. The several properties on which mechanical and physical forces are made to act, in order to change the forms of bodies for the uses of life, are the following:—

1. *Divisibility*; 2. *Impenetrability, or repulsiveness*; 3. *Permeability, or porosity*; 4. *Cohesiveness*; 5. *Ductility*; 6. *Malleability*; 7. *Inertia*; 8. *Gravitation*; 9. *Elasticity*; 10. *Softness*; 11. *Tenacity*; 12. *Fusibility*; 13. *Crystallizability*.

I. *DIVISIBILITY*.—To this head may be referred the following processes of Art. 1. Pulverizing dry substances; 2. Triturating solid substances, with liquids, into a pasty consistence; 3. Boring; 4. Sawing; 5. Rasping and chipping; 6. Tearing; 7. Abrading surfaces; 8. Splitting; 9. Planing; 10. Turning surfaces; 11. Shearing surfaces; 12. Granulating and shot casting; 13. Distilling; 14. Subliming; 15. Exploding, or blasting for mining purposes; 16. Comminution of earths and soils.

1. *Pulverization*.—This operation is performed by various machines, according to the nature of the substance to be pulverized; such as corn-mills, flour-mills, drug-mills; manganese, chrome ore, and other mills for pulverizing mineral substances; dye-mills, stamp-mills, and other crushing machinery, &c.

2. *Trituration*.—To this head belong colour or paint mills, flint and other pottery mills, and comminuting processes; certain drug-mills; patio, and other amalgamation works, &c.

3. *Boring*.—Here the action of the cutter and drill is employed to form cylindrical cavities for steam-engines, hydraulic-presses, pump-barrels, cannon, gun-barrels; mine and artesian well-boring, &c.

4. *Sawing* comprehends every species of mill for cutting off flat plates of timber, stone, metal, &c.; such as saw-mills of every kind, marble-mills, stone-cutting works, &c.

5. *Rasping and chipping*.—Under these titles would fall masonry or stone-hewing, the mechanical part of statuary; rasping-mills for logwood, beet-root; and machines for chipping the teeth of wheel patterns, &c.

6. *Tearing*.—To this head may be referred paper-making, as well as flax heckling, for tearing off its parenchymatous matter, threshing-machines, &c.

7. *Abrasion of surfaces*.—This process will comprehend all filing and polishing operations, such as grinding and polishing of metals, of glass, marble, &c. Mirror and lens making belong to this class, as well as cutlery grinding of every kind.

8. *Splitting*.—Here would be considered the art of splitting skins for cards and parchment; splitting timber for laths, whalebone, and other fibrous substances, &c.

9. *Planing*.—Planing machines, now so beneficially used in the working of metals for machinery of every kind, as well as for flooring, and other planks of wood, fall under this division, as well as the key-groove cutting-machines, and many others.

10. *Turning*.—Every species of turning lathe in which a cutting edge is applied to surfaces in a state of rapid revolution, belongs to this process.

11. *Shearing*.—This process includes that beautiful branch of manufacture, by which woollen cloth, after being woven, is finished, with a soft smooth surface. It is performed on the principle of shaving, by moving a slightly inclined, or nearly horizontal blade, close to

the downy surface. As mowing machines operate in a similar way, they may be considered under this head.

12. *Granulating and shot casting*.—In these processes, the property of divisibility is acted on by the solvent power of heat, which, skilfully made use of, saves the labour of grinding a fusible solid. The melted mass being nearly void of cohesion, is separable like water into a shower of drops, which congeal in the course of their descent from the top of the shot-towers into the water-cistern at their base. The refiner of gold and silver, and the alloyer in general, granulate their melted metal, by pouring it on a bundle of moist twigs, or by trituration in a cold mortar.

13. *Distilling*.—Here again the force of caloric divides matter, whether solid or liquid, into separate substances, in the order of their expansiveness by that physical agent. All the varieties of stills belong to this head, all the mechanical processes of the rectifier and compounder of alcohol, the manufacturers of coal gas and pyroligneous acid, &c.

14. *Subliming*.—The same physical influence is here employed to divide and comminute, by separating the more volatile parts of bodies, which, in the aëriiform state of repulsiveness among their particles being suddenly cooled, precipitate in an impalpable powder.

15. *Exploding, or blasting*.—The property of divisibility is, in this case, acted upon and made effective, by the sudden generation of elastic fluid in such force as to overcome the cohesion of the solid mass. Under this head might perhaps be considered the simple action of ignition in effecting the disintegration of rocks for mining purposes.

16. *Comminuting or disintegrating earths and soils.*  
 —Tillage, with the spade, pickaxe, plough, harrow, &c.  
 To till the ground, or break the stubborn glebe with the furrow, is merely a division of its parts, to render the earthy substances friable, in order that the roots of plants may insinuate themselves more easily into it, that the rains and dews may penetrate more readily to these roots, that any excess of water may more freely exhale; and lastly, that the air of the atmosphere may get access to the vegetable mould of the soil, and convert it into soluble vegetable food, on principles developed by chemistry. The proper comminution of the soil by the plough and the harrow is serviceable also in destroying weeds, in bringing up to the surface fresh layers of earth, incorporating with it manure and other improvers, and in giving a slope to the ground favourable to its drainage. The importance of the pulverizing process is so well known, that tillage and agriculture have been long used as synonymous terms. All its processes act on the divisibility of the soil in three ways: 1. By the spade; 2. by the pickaxe and hoe; 3. by the plough, with its wedge-shaped share, which cuts obliquely through the clod, and turns it over to one side. Spade tillage suits best for a soil which is uniform in texture, deep, compact, level, and not very stony or moist. That of the pickaxe, or mattock, is most proper for land that is stony, dry, difficult to penetrate, and uneven, or sloping, in its surface. The plough, though a less perfect pulverizing agent, is more expeditious, economical, and generally applicable to grounds, excepting to steep declivities. The best form of ploughshare for dividing the soil is an interesting problem in mechanical philosophy.

II. IMPENETRABILITY.—This property gives rise to works for separating, by compression, the liquid from the solid parts of bodies, in virtue of the impenetrability of matter. Under this class are comprehended oil-mills, sugar-mills, beet-root presses, cocoa-nut lard-mills, all of which operate either by the flat pressure of a hydraulic or screw press, or by the pressure of surfaces rolling on each other; the object being to extract incompressible liquid matter from the interstitial pores of a solid. Die presses for coining, and transferring engravings from hard steel to soft steel or copper, may be arranged either under impenetrability or condensability.

III. PERMEABILITY.—This property admits of one or more matters to pass through or impregnate the interstices of solids. Filtering apparatus for sugar refiners, for purifying oils, and many other liquids, by means of bibulous paper, sand, stones, with or without external pressure, as well as dyeing, calico-printing, letter-press, copper-plate, and lithographic printing, belong to this head.

IV. COHESION, DUCTILITY, MALLEABILITY, LAMINABILITY.—These are kindred properties, and are the foundations of kindred works, such as wire-drawing, and tube-drawing apparatus, rolling-mills, flattening-mills, tilting-mills, laminating-mills, gold and silver leaf-beating, &c.

V. INERTIA, GRAVITATION.—In reference to these properties, the raising, lowering, and removing weights come to be considered. These effects are produced by cranes, capstans, windlasses, gins for raising coals, and other minerals; pulleys, wheels, and axles; inclined planes for joining different canal levels;

pumps, for lifting water; dredging machines; carriages of every kind. The equilibrium of architecture and of ship-building may be treated here.

VI. ELASTICITY, SOFTNESS, AND TENACITY.—These three properties are combined in the constitution of tortile fibres used for making webs of various kinds, and give rise to the arts of spinning, knitting, and weaving mineral, vegetable, and animal filaments; the principal of which are the manufactures of cotton, wool, flax, and silk. Rope-making and wire-working belong also to this head. Under tortility must likewise be considered the processes of fulling, felting, and the manufacture of hats.

VII. FUSIBILITY.—To this property belong foundries of the different metals, and the mechanical part of glass-making, as well as casting figures in plaster, wax, &c.

VIII. CRYSTALIZABILITY.—This property includes the various physical principles of the manufactures of saline substances, such as salt-works, nitre-works, alum-works, &c.

The sixth of the above divisions comprehends the mechanical arts most interesting to man. Here he has exercised his best talents in producing raiment of every variety for his comfort and decoration; and here, accordingly, he has organized systems of industry no less remarkable for their magnitude than for their perfection. In certain parts of the clothing manufactures moreover automatic machinery has been so extensively substituted for the labours of intelligence, that the superintendence of young persons has come to supersede the costly toil of adults to such an extent, that the vast multitudes of children thus em-

ployed have, of late years, attracted the earnest consideration of the public, and have, in consequence, led the legislature to frame a code of factory laws for their protection. These relate solely to the arts of spinning and weaving by power, as exercised in cotton-mills, woollen-mills, flax-mills, and silk-mills.

#### *Chemical Manufactures.*

Those arts which involve the operation of chemical affinities, and consequently a change in the constitution of their subject matter, may be distributed into three groups, according to the kingdom of nature to which they belong; the mineral, the vegetable, and the animal.

Class I. The chemical manufactures employed on mineral, or more accurately speaking, inorganic matter, may be arranged conveniently under four heads:—  
1. Those which operate on metallic bodies; 2. On earthy and stony substances; 3. On combustibles; 4. On saline substances.

Class II. The chemical manufactures which modify vegetable substances may be distributed according to the chemical analogies of these substances; as starch, sugar, oils, essences, &c.

Class III. The chemical manufactures which modify animal substances may likewise be distributed according to the chemical analogies of their respective objects; as gelatin or glue, albumen, skin, horn, &c.

Class I. Order 1. Arts and manufactures of metallic substances:—

1. Extraction, purification, alloying of the precious metals, gold, silver, &c., and their different chemical preparations.

2. The arts of smelting copper, and making its alloys, its saline, and other preparations.
3. The arts of smelting iron, and making its alloys, its saline, and other preparations.
4. The arts of smelting lead, &c.
5. The arts of smelting tin, &c.
6. The arts of smelting mercury, &c.
7. The arts of smelting zinc, &c.
8. The arts of smelting bismuth, &c.
9. The arts of smelting antimony, &c.
10. The arts of smelting cobalt, &c.
11. The arts of smelting nickel, &c.
12. The arts of smelting manganese, &c.
13. The arts of smelting arsenic, &c.
14. The arts of smelting chromium, &c.
15. The arts of extracting the other metals, cadmium, bismuth, rhodium, &c.

Class I. Order 2. Arts and manufactures of earthy and stony substances.

1. Those which operate on calcareous substances; such as limestones, gypsum, fluor-spar, &c. Mortars.
2. Those which operate on argillaceous earth or clay; as the manufactures of pottery, porcelain, &c.
3. Those which operate on siliceous matter. Manufacture of glass.

Class I. Order 3. Arts and manufactures of combustible substances.

1. Sulphur. Manufacture of sulphuric acid.
2. Coal. Manufacture of coal gas, and its various products.
3. Amber, petroleum, bitumen, asphaltum.

Class I. Order 4. Arts and manufactures of mineral saline substances.

1. Rock, or sea-salt; salt works of various kinds; manufacture of muriatic acid, and of chlorine. Art of bleaching.

2. Alum—its manufacture.
3. Natron, or soda—its manufacture.
4. Potash—its manufacture.
5. Sal-ammoniac—its manufacture.
6. Nitre—its manufacture; that of **gunpowder**, nitric acid, &c.
7. Borax—its manufacture.
8. Sulphate of magnesia—its manufacture.

Class II. The chemical manufactures of vegetable substances.

Order 1. The art of extracting and refining sugar.

2. The art of extracting and purifying starch.
3. The art of making artificial gum.
4. Extraction and purification of fixed oils, drying and unctuous oils, such as linseed-oil, castor-oil, nut-oil, &c., oil of olives, of almonds, of the palm, of the cocoa-nut, &c. Manufacture of oil soaps.
5. Extraction and purification of volatile oils, such as oil of turpentine, citron, anise, cinnamon, lavender, &c. Art of the perfumer.
6. Art of purifying and bleaching wax.
7. Extraction and purification of resinous bodies, such as common rosin, lac, mastic, &c. Manufacture of varnishes and sealing-wax.
8. Extraction of *caoutchouc*; caoutchoucine. Manufacture of water-proof cloth.
9. Preparation of extracts for the apothecary; extract of nut-galls. Manufacture of ink.
10. Extraction of the colouring matters of plants,

as of madder, safflower, archil, logwood, weld, indigo, &c. Arts of dyeing and calico-printing.

11. Art of fermenting vegetable juices and extracts into wine, beer, &c. Breweries, distilleries, &c.

12. Art of fermenting vegetable juices and extracts into vinegar.

13. Art of fermenting dough into bread. Baking.

14. Decomposition of wood by fire in close vessels. Pyroxilic acid, spirit, and naphtha.

15. Preparation of composts by the putrid decomposition of vegetable substances. Agriculture as a chemical art.

Class III.—The chemical manufactures of animal substances are,—

1. The art of extracting and purifying gelatin; or the manufactures of glue, size, isinglas, &c.

2. The art of extracting butter from milk. Manufacture of cheeses.

3. The art of converting skin into leather, or tanning.

4. The art of the tallow-chandler. Purification of spermaceti.

5. The manufacture of tallow and other soaps.

6. Preparation of animal pigments—carmine from cochineal.

7. The art of curing animal food.

8. Decomposition of animal substances by fire. Manufacture of sal-ammoniac, and of Prussian blue.

The preceding table presents merely the more general objects and subdivisions.

### CHAPTER III.

#### *Topography and Statistics of the Factory System.*

THE topography of the textile manufactures is a most interesting subject of philosophical research. It investigates the causes why one district is occupied chiefly with cotton fabrics, a second with flax, a third with wool, and a fourth with silk. The reason of the predominance of factory over agricultural employment in any province of this island is more obvious, and may be generally traced to the abundance of motive power, in the form of fuel or water-courses.

Some circumstances of ancient date, now little known, have had a share in determining the locality of particular manufactures. Where the soil is too thin to be productive to the plough, it is converted into sheep walks, as in the north-eastern parts of Scotland, and thereby gives birth to the woollen trade, first in a handicraft way, and afterwards by machinery. The convenience of harbours for intercourse with foreign countries, rich in certain raw materials, naturally determines their importation and also their manufacture, provided the population of the neighbourhood be numerous, active, and possessed of natural resources in fire and water power. Thus the eastern counties of Scotland having long carried on a shipping trade with the opposite coast of Europe, where flax is much cul-



tivated, have been led to import it largely, and to work it up on a corresponding scale. On the other hand, cotton being imported chiefly from the West Indies and United States into the two great western ports of the island, Liverpool and Glasgow, in the neighbourhood of districts abounding in rivers and coal mines, naturally occasioned the development of the cotton manufactures of Lancashire, Lanarkshire, and Renfrewshire. What cause excluded them from Bristol?

The worsted trade of England has been remarkably developed in Leicester, the centre of the district where the long-woolled breed of sheep has been reared with greatest success. The softer and shorter stapled fleece of the sheep reared in the south-western counties of England naturally suggested the establishment of the fine woollen-cloth manufacture in Gloucestershire, Somersetshire, and Wiltshire. The peculiar facilities for steam and water power enjoyed by Yorkshire have favoured the rapid extension, within a few years, of the same manufacture in several parts of that county. As soon, however, as machinery becomes generally prevalent in any district, and possesses ample resources in motive agents for its unlimited application, it will attract to that district a great many manufactures in addition to the indigenous, and may, in fact, by the influence of such advantages, deprive other districts of their original staple trade. The silk-weaving of England sprung up in the cheap end of its metropolis, because it had to seek customers for its expensive ornamental fabrics among the luxurious population of the court; and there it continued for a century, flourishing and fading in alternate vicissitudes, though progressive on the whole, till it has found in the self-acting power

machinery of the cotton-factory districts an attractive influence injurious to the monopoly of Spitalfields.

The mechanical skill which Leeds long exercised in the coarse woollen fabrics has been latterly directed by some of its intelligent manufacturers to flax-spinning, and has given to this branch a remarkably rapid development.

Sometimes political events or local disturbances turn the current of manufactures out of their native beds into distant and unthought-of channels. The inquisitorial cruelties of the duke of Alva, and the revocation of the edict of Nantes by Louis XIV., violently transplanted from the Netherlands and France a great many thriving trades into the other countries of Europe. The bobbin-net lace manufacture was the foster-child of Nottingham, Loughborough, and some of the villages placed betwixt them, where it was growing up into a vigorous manhood, till it was frightened from its native home by the frame-breakers, who succeeded the Luddites in their riotous career. Its patronizing capitalists were forced to make a tour through the remote provinces of Wales, and the south-west of England, on purpose to seek a quiet retirement, where they might set down their ingenious industry aloof from lawless ruffians. Thus the lace business suddenly emigrated to Tiverton, Barnstaple, Taunton, and Chard, places farther beyond London to the south, than its birth-place Nottingham was to the north.

The following table exhibits the topographical distribution of the manufactures among the counties of Great Britain. In former times, when the textile manufactures were handicraft occupations, they were established, as I have said, in reference to the near supply

of the raw materials, and to streams of pure water for scouring, bleaching, or turning a little mill. Since the introduction of machinery driven by steam-power, and the extension of inland navigation for the cheap transport of coals and goods, manufacturers have taken a wider range in selecting their seats, and have been guided in this respect as much by the convenience of a good mart for home sale and exportation, as by any other consideration. From this cause, Manchester and Glasgow have attracted them in extraordinary numbers. There is, however, something apparently capricious, or at least difficult to account for in this business. If cheap fuel, an abundant population, and a commodious sea-port, be the circumstances most favourable to the erection of manufactures, it may be asked, why have they not led to their establishment in the neighbourhood of Edinburgh, where these three conditions concur? Much may be ascribed to the countervailing influence of a previously organized emporium. Thus, with the exception of a few large factories at Aberdeen, and one at Stanley, near Perth, the Scotch cotton manufacture is almost entirely confined to the Glasgow district. The energy of two or three capitalists will sometimes determine the rise of a manufacture round their residence, though apparently not the most congenial soil for its growth. To this circumstance is probably owing the factory enterprise of Aberdeen, at a distance from coals, and the non-factory character of Edinburgh, built on the border of a great coal-field. As railways multiply, they will multiply the sites of manufactures, and lead to their establishment in many inland districts where the population is redundant in reference to rustic occupation, and ready to dispose of its labour at a low rate.

The local fixation of a manufacture is a remarkable circumstance. It has been found by the Glasgow people impossible to transfer to themselves with all the knowledge and opportunities they possess the peculiar fabrics of Manchester; and *vice versâ*, the Manchester people have made many efforts to naturalize the muslin trade of Glasgow and Paisley, but never with any advantage, so that the warehousemen of the one town continue to get their supplies reciprocally from the other.

It is not pretended that the same quality of goods could not be made indifferently at either of these emporia, but it could not be made at the same average cost. Each of them endeavours, perhaps too much, to outstrip the other in the race of reducing prices; but both have greatly benefited by the general cause of that reduction, namely, the fall in the price of the raw material and of the machinery.

American cotton-wool, which three years after the peace was 18*d.* a pound, is now about 7*d.*, and other cottons in proportion. Now, in respect of a very common article, supposing the price of the cotton-wool 7*d.* the price of the cloth would be from 13*d.* to 14½*d.* a pound. The throstle twist, which has been so largely exported of late years, is made with almost no manual labour; and though it be low priced, it still remunerates the skilful manufacturer of good capital. And notwithstanding the competition of the cotton trade in foreign countries, the export of twist from us to them has materially increased. This increase may be attributed to the very low price at which we can sell it. Another advantage we possess is the cheapness as well as excellence of our machinery. A machine which would

cost only 30*l.* in Manchester, would cost 54*l.* in the United States ; and a dozen of spindles which would cost only 4*s.* in the former place, would cost 14*s.* 6*d.* in the latter. Hence the cotton manufacture of Russia is hitherto confined to the Emperor's establishment, a pet mill, carried on without reference to profit or loss. Along with the fall of the raw material, if we consider the improvement of machinery and of the workmen's skill in using it, we shall understand how business can be carried on still with profit, though with a much smaller one than at the period of the peace.

The factory system extends no farther north than Aberdeen, in which city it has been applied on a considerable scale in several mills, in some to worsted, and in others to flax and cotton, by the enterprising spirit of the inhabitants, in a locality favoured by two powerful streams and a convenient harbour. In coming southwards, numerous flax-mills occur along the whole line of the eastern coast ; at Bervie, Montrose, Brechin, Dundee, Arbroath, Cupar, Kirkland, Dysart, Kircaldy, Kinghorn, Dunfermline, Perth, Blairgowrie ; of which nearly forty of different magnitudes are referred to by the Factory Commissioners. At Bannockburn and Stirling, are a few woollen-mills. The Stanley mills, near Perth, and the Deanston mills, near Doune, are two great cotton works belonging to Glasgow houses, which were planted in these remote localities on account of their supply of water-power, and an industrious population.

The next great factory district is Glasgow, and its dependent stations at New Lanark, Paisley, the water of Leven, Kilbarchan, Johnstone, Lochwinnoch, Rothesay in the isle of Bute, and Old Kilpatrick in

Dumbartonshire, which are almost entirely occupied with cotton fabrics, with the exception of Paisley, partially employed in the manufacture of fancy silk goods. To the south of the river Forth, the flax-spinning mill of Mr. Craig, at Preston Holme, ten miles from Edinburgh, deserves to be noticed on account of its salubrious arrangements.

With the exception of Carlisle and its immediate neighbourhood, factories are but thinly spread over the four northern counties of England, the total amount being only fifty-two, exclusive of Kendal, where there is a considerable number occupied chiefly with woollen fabrics. In the remarks on the population of the different counties of England a general view is given of the nature and extent of their respective manufactures.

Few factories are yet established in Ireland, except at Belfast, where several considerable cotton-mills have been for many years in activity, and some large flax-mills have been recently erected. A few manufactures exist in the vicinity of Dublin, particularly in the calico-printing department.

County.	Population	Agricultural Labourers	Manufacturing Labourers	Remarks.
YORK.				
East Riding .	168,891	14,388	175	Ropes and sail cloth at Kingston-upon Hull, 100
City & Ainsty .	35,362	1,437	211	Linen manufacture, 200.
North Riding .	190,756	18,980	1,005	Domestic weavers numerous, but scattered, sail cloth at Whutby, 90.
West Riding .	976,350	35,138	74,669	Woollen cloth greatly increased during the war which terminated in 1815. In consequence of the introduction of machinery like that invented for the cotton trade, much of the west country clothing trade was transferred to this county. In the three wapentakes of Agbrigg, Morley, and Skyrack, are found 17,000, 22,000, and 29,000 males, twenty years old thus employed, in all 68,000. The limit of the county of Lancaster defines pretty exactly the demarcation line of the woollen and cotton trade in this part of the kingdom Halifax 12,000; Leeds 9,400; Bradford 7,900, Almondbury parish 4,500, worsted and silk at Huddersfield, 3,700, Kirk Burton 2,400, Calveley 2,100 At Saddleworth, the frontier towns, &c 1,300 in woollen, and 1,500 in the cotton manufactures. In linen and thread, at Leeds 500, at Barnsley 1,300, wapentake of Claro, 1,000, in linen and cotton fabrics at Stanchise and Eweross, 2,300; in woollen and linen promiscuously in Stifforth and Staincross wapentakes, 1,000, linen weavers 100 at Ripon liberty Iron and hardware at Rothelham, Sheffield, Bradfield, and Ecclesfield. Carpets at Dewsbury.

## SUMMARY OF ENGLAND.

Total persons, 13,091,005:—Agricultural labourers, 744,407  
 Labouring occupiers . 94,833

839,290

Manufacturing labourers, 314,106:—Other labourers, 500,950

## WALES.

County.	Population.	Agricultural Labourers.	Manufacturing Labourers.	Remarks.
Anglesey .	48,325	5,406	120	Weaving domestic woollens, 120 males.
Brecon . .	47,763	3,978	551	Ditto 80; iron-works, 470.
Cardigan . .	64,780	6,684	246	Domestic woollens and flannels, 240.
Carmarthen .	100,740	10,014	292	Ditto ditto, 260.
Carnarvon . .	66,448	6,597	143	Ditto ditto, 100.
Denbigh . .	83,629	8,089	235	Ditto ditto, 200.
Flint . . .	60,012	5,038	630	At Holywell, in silk and woollen goods, and in paper, 256. At Mold, in cottons, 230; weavers scattered, 40
Glamorgan .	126,612	7,123	1,993	Iron works as at Merthyr Tydfil; weavers of woollens, scattered, 168
Merioneth . .	35,315	3,847	194	Flannel and other weavers, 200.
Montgomery .	66,482	7,357	1,630	A great many weavers of domestic woollens and flannels, of which 1,169 adult males are noted in the return.
Pembroke . .	81,425	7,939	131	Weavers as above, 130.
Radnor . . .	24,651	3,362	42	Ditto not enumerated, wool-sorters 14.

## SUMMARY OF WALES.

Total persons, 806,182:—Agricultural labourers, 55,468  
 Labouring occupiers . 19,966

75,434

Manufacturing labourers, 6,218:—Other labourers, 31,571.

## SCOTLAND.

County.	Population.	Agricultural Labourers.	Manufacturing Labourers.	Remarks.
Aberdeen . . .	177,657	15,030	2,294	In linen, cotton, and woollen manufactures, 1,600 in the city of Aberdeen. In the county, 700 weavers of woollen and linen, many of them for domestic use.
Argyll . . .	100,973	11,533	816	Domestic weavers; a few.
Ayr . . .	145,055	6,583	8,311	On silk, woollen, cotton, and linen fabrics, 8,300 males are employed, at Kilmarnock, in the carpet and bonnet manufactures, &c. 1,300; at Girvan, in weaving muslins, &c. 1,100, at Maybole 600; at Loudon 500, at Beith 400; at Catrine cotton factory and neighbourhood, 300.
Banff . . .	48,604	4,904	240	In woollen and linen manufacture, 240, chiefly for domestic use.
Berwick . . .	34,048	2,040	399	Flax dressing and weaving linen 380.
Bute . . .	14,151	815	215	In cotton-spinning and weaving for the Glasgow market, 200.
Caithness . . .	34,529	3,786	88	
Clackmannan . . .	14,729	443	259	Cotton-weavers 200: a few woollen-weavers.
Dumbarton . . .	33,211	1,347	1,998	About 2,000 engaged in the cotton manufactures as spinners, weavers, calico printers, &c.
Dumfries . . .	73,770	4,866	1,602	Cotton manufacture, 1,500 weavers for the wholesale markets.
Edinburgh . . .	219,345	3,911	1,267	Preparation of flax, weaving linen and woollen-cloth, 200 men; sail-cloth and nets, 100, paper, 60 and upwards. Shawl weavers and manufacturers of fancy articles, 800.
Elgin . . .	34,231	2,844	199	Linen & woollen-weavers, 200.
Fife . . .	128,839	5,047	7,729	Flax, tow, and hemp manufactures much cultivated. At Dunfermline nearly 2,700 in weaving damasks; at Dysart nearly 700; and in other places considerable numbers, amounting in the whole to 7,500 adult males.
Forfar . . .	139,606	5,565	8,574	At Dundee, the capital of the linen trade, 3,300 males employed in it; at Arbroath upwards of 1,200; at Forfar 900, at Kerriemuir nearly 600; at Brechin upwards of 400, at Liff upwards of 320. Canvass and strong linens are the staple manufacture, and furnish employment to 8,000 men in this county; to which number may be added 500 weavers of linens and woollens for domestic use.

County.	Population.	Agricultural Labourers.	Manufacturing Labourers.	Remarks.
Haddington . . .	36,145	2,960	194	Domestic weavers, 150.
Inverness . . .	94,797	11,455	344	Ditto, ditto, 340.
Kincardine . . .	31,431	2,963	726	In weaving dowlas, household linens, and a few woollens, 700 men are employed.
Kinross . . .	9,072	530	562	Cotton-weavers 500; and a few in woollens and linens.
Kircudbright . . .	40,590	3,138	529	A number of scattered weavers of cotton goods for Glasgow manufacturers.
Lanark . . .	316,819	5,152	26,677	This county embraces every department of the cotton manufacture, and has upwards of 7,000 weavers in its different small towns. In Glasgow 19,913 males are engaged in manufactures, chiefly of cotton goods.
Linlithgow . . .	23,291	1,131	560	Cotton weavers 500; chiefly for Glasgow houses.
Nairn . . .	9,354	757	54	Weavers of cloth for family use.
Orkney and Shetland } . . .	53,239	7,246	170	Ditto ditto.
Peebles . . .	10,578	887	173	In weaving cotton, flax, and wool, 170 adult males.
Perth . . .	142,894	9,565	4,942	Cotton weaving, 900 in the town of Perth. At Dunblane 200, and at Dunning 156 in woollens; at Errol upwards of 200 on linens; besides about 1,700 in other places, chiefly in the cotton manufacture, in the whole upwards of 3,000 males so employed.
Renfrew . . .	133,443	2,547	9,617	This is second in Scotland only to the county of Lanark for cotton manufactures; and perhaps it is the first for silk. In the town of Paisley, 6,000 males are thus employed; and 3,000 in other places.
Ross & Cromarty . . .	74,820	9,218	383	320 "home-cloth" weavers.
Roxburgh . . .	43,663	3,372	1,076	Weavers and stocking makers, 1,000, several of them employed on carpets and other woollen articles.
Selkirk . . .	6,833	535	154	Weavers, chiefly of woollens, 150.
Stirling . . .	72,621	3,412	3,376	Woollen and cotton fabrics. At St. Neman's more than 500 men in weaving tartan or plaid, and carpets; at Stirling 315, in cottons, at Campsie 450, and cotton weavers at Kilsyth 424, flax-dressers in various places; in all about 2,250 in textile manufactures.
Sutherland . . .	25,518	9,520	50	50 weavers of "home cloth."
Wigtown . . .	36,258	3,156	416	Woollen, cotton, and linen weavers 400.

## SUMMARY OF SCOTLAND.

Total persons, 2,365,114:—Agricultural labourers, 87,292
Labouring occupiers .. 53,966
141,258

Manufacturing labourers, 83,993:—Other labourers, 76,191.

## GENERAL SUMMARY OF GREAT BRITAIN.

Total persons, 16,539,318:—Agricultural labourers, 887,167:—Occupiers not employing labourers, 168,815:—Total agricultural labourers, 1,055,982:—Manufacturing Labourers, 404,317.

Persons employed in retail trade, or in handicrafts, as masters or workmen, 1,159,867.

Total adult males employed in arts and trades, 1,564,184, being about fifty per cent. more than those engaged in agriculture.

## BOOK THE SECOND.

## CHAPTER I.

*Examination of the Textile Fibres,—Cotton, Wool, Flax, and Silk.*

MAN has been properly defined a tool-using animal. This faculty was first exercised in agriculture; for we read that Adam was set to his penal task of tilling the ground immediately on his expulsion from Eden. He was then clothed in coats of skins. We have no authentic notice in sacred or profane history when tools were first employed in making cloth; but there can be little doubt that fibres of wool were twisted and woven, under the tuition of their benignant Creator, by the family of Jabal, the antediluvian shepherd, as we find raiment familiarly spoken of immediately after the flood. This valuable art was transmitted by the posterity of Noah to the oriental nations, and was soon carried to high perfection in Egypt and India, but seems to have been lost by many of the migrating tribes in their pilgrimages to the north and the west.

The early inhabitants of Greece were dressed in skins. Their posterity had an obscure tradition that their forefathers had been taught the art of spinning by a divine instructress, which, with their usual fancy, they afterwards embodied in a mythological legend. In these primeval times, indeed, so few generations had intervened since the days of Noah, "the just man and perfect who walked with God," that the sentiment of heavenly communion prevailed among most nations,

and was particularly cherished by the sensitive and intellectual inhabitants of Greece. It was Ceres who showed them how to cultivate grain, Bacchus to plant a vineyard, and Pomona to graft fruit trees; each instruction being deemed divine. Minerva was worshipped for the sake of sundry benefactions. In the fruit of the olive tree, she furnished bland oil to season their corn or fish as well as to trim the student's lamp; and in the distaff and the loom she taught the art of converting loose flocks of wool into elegant and durable garments.

These implements were the favourite attributes of the tutelary power of Athens, and constituted in the eyes of its ingenious citizens her chief claim to a seat on Olympus. According to Homer, spinning and weaving appear to have been held in the highest reverence in the heroic ages; they were not vulgarized by common hands, but were the proud prerogatives of queens and princesses. Nor need we wonder at the honours paid to the loom by a people ill supplied with the conveniences of life, however heroic their conduct and sentiments might be; for if an English maiden were now set down among the simple-minded inhabitants of some lonely Australian isle with a spinning wheel and knitting frame, she would doubtless be hailed as a celestial visitant.

We above all others ought to respect the artisans of such invaluable industry, however lowly their modern place in artificial society. To mock the humble toil and obscure destiny which pre-eminently contribute to the grandeur of Great Britain would be a despicable pride. The few among our ancestors who in the time of Julius Cæsar aspired to the luxury of dress, wrapped themselves in the hides of beasts killed in

the chase; and it was only after being subdued by him and his successors, that they learned the mystery of working wool into a robe to cover their calico skins. The Romans, by imparting such valuable instruction to the shivering tenants of the forest and morass, came to be regarded by our forefathers as benignant patrons, whose departure in the decline of the empire was deprecated and deplored by them in the most affectionate manner.

The textile fibres, cotton, wool, silk, flax, and hemp, differ considerably from each other in structure; the first three consist of definite and entire filaments not divisible without decomposition; the last two consist of fibrils bundled together in parallel directions, which are easily separable into much more minute filaments. These bundles are bound by parenchymatous rings, from which they are freed in the operations of heckling, spinning, and bleaching. Weak alkaline leys dissolve these rings without acting on the linen fibres.

The downy filaments of cotton are cylindrical tubes in the growing state, but get more or less flattened in the maturation and drying of the wool. They are shut at both ends. Their flattened diameter varies from  $\frac{1}{500}$  to  $\frac{1}{3000}$  of an inch, according to their quality, as will be fully described in the treatise on the cotton manufacture.

In October, 1833, I paid a visit to Paris chiefly with the view of investigating the botanical relations of the different cottons of commerce, and learning what progress was making in the application of the microscope to organic chemistry. I had the good fortune to procure at that time an achromatic microscope of extraordinary power and distinctness, made by Georges Oberhäuser, a German optician resident in that city, and I

directed it immediately to the examination of cotton and flax fibres. In December or January following, I made known the results of my observations to several of my scientific friends at the Royal Society, and being requested by Mr. Pettigrew to submit mummy cloth to my microscope, I accordingly did so, and communicated to him the following statement, which was published in March, 1834, in a foot note to page 91 of his interesting History of Egyptian Mummies:

“Dr. Ure has been so good as to make known to me that which I conceive to be the most satisfactory test of the absolute nature of flax and cotton, and in the course of his microscopic researches on the structure of textile fibres, he has succeeded in determining their distinctive characters. From a most precise and accurate examination of these substances, he has been able to draw the following statement:—

“The filaments of flax have a glassy lustre when viewed by daylight in a good microscope, and a cylindrical form, which is very rarely flattened. Their diameter is about the two-thousandth part of an inch; they break transversely with a smooth surface like a tube of glass cut with a file. A line of light distinguishes their axis, with a deep shading on one side only, or on both sides according to the direction in which the incident rays fall on the filaments.

“The filaments of cotton are almost never true cylinders, but are more or less flattened or tortuous; so that when viewed under the microscope they appear in one part like a riband from the one thousandth to the twelve-hundredth part of an inch broad, and in another like a sharp edge or narrow line. They have a pearly translucency in the middle space, with a dark narrow border at each side like a hem. When broken

across, the fracture is fibrous or pointed. Mummy cloth, tried by these criteria in the microscope, appears to be composed, both in its warp and woof yarns, of flax and not of cotton. A great variety of the swathing fillets have been examined with an excellent achromatic microscope, and they have all evinced the absence of cotton filaments.’ ”

A few months after the date of this publication, on showing my very excellent friend, James Thomson, Esq. of Clitheroe, F.R.S., then in London, the appearance of cotton fibres in my microscope, he informed me that the subject of mummy cloth, with which I had been lately occupied, had several years before engaged his attention. He has since published an ingenious paper on the subject with sketches of cotton and flax fibres, taken from the microscope by Mr. Bauer, who represents flax as uniformly marked at regular distances in each filament with channelled articulations at right angles to its axis; and cotton as consisting of two cylindrical cords, connected by a thin membrane, which are twisted spirally about each other. It appears to me that the cotton has been viewed by him when impasted in Canada balsam or some similar varnish, whereby its fibres have derived certain peculiarities of appearance, which are not visible when they are viewed in less powerful refracting media.

Fig 4.

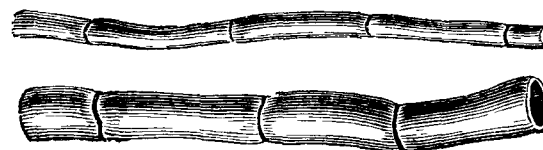

Flax, as represented by Mr. Bauer.



Fig. 5.



Cotton, as represented by Mr. Bauer.

The figures of flax as seen in my microscope with a magnifying power of 300 are exceedingly distinct, and yet they never exhibit rectangularly placed, cane-like furrowed joints; they show occasionally, indeed, cross lines, at variable angles to the axis, but at irregular intervals, though frequently they show no cross lines at all, even when the filaments are impasted in balsam.

Fig. 6.



Sea Island Cotton, as viewed by me, in balsam.

When fibres of cotton are viewed in the balsam, they appear very different in the microscope, from what they do when viewed alone or immersed in a film of water, in consequence of the small difference between their refractive power and that of the medium. All the beautiful veining of the riband surface in these circumstances disappears, and of course none of it is represented by Mr. Bauer. The thin shrivelled edges of the ribands also look as if they were enlarged into cylindrical cords. In fact the distinctive marks of the different commercial samples of cotton—the Sea Island, the Upland, the New Orleans, the Surat, &c., which constitute the valuable objects of this kind of research, are in that way entirely lost and confounded.

Fig. 7.

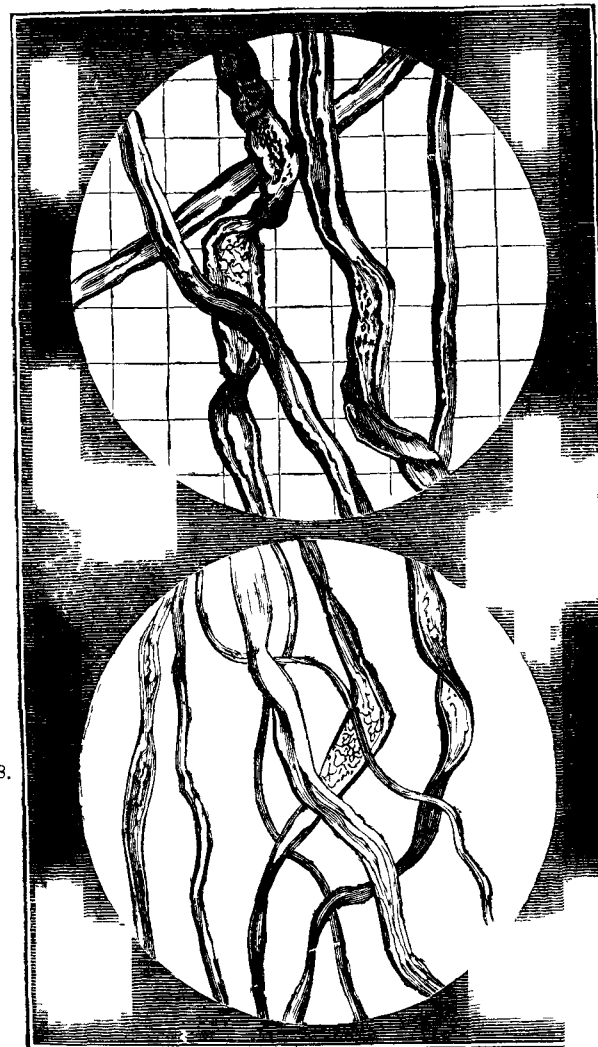

Fig 8.

Fig. 7.—Smyrna Cotton, shown on the micrometer lines, in glass,  $\frac{1}{1000}$  of an inch apart.—One million of these squares are contained in one square inch.

Fig 8.—Surat Cotton—both are irregular riband-form.

When viewed in their dry state or moistened with water, the Sea Island and the Smyrna cottons are seen to be remarkably dissimilar (compare fig. 7 and fig. 8); but when viewed, as Mr. Bauer seems to have done, in balsam, they are hardly distinguishable. Unless great attention be bestowed on the refractive influence of the media in which objects are placed for examination, the microscope is sure to become the source of numberless illusions and false judgments, as M. Raspail has abundantly shown in his *Chimie Organique*. I have found liquid albumen (white of egg) a good medium for many objects, as it serves to show the outlines distinctly without distorting them.\*—See note A.

Some modern inquirers pique themselves on their power of vision with a single lens microscope; but

\* During my late visit to Manchester, I had an opportunity of exhibiting to several skilful spinners the powers of my achromatic microscope to distinguish the different qualities of cotton-wool, and of satisfying their minds that such an instrument would prove a valuable guide in the purchase of cotton. Accordingly many manufacturers expressed their intention to become possessed of a similar microscope. I may here relate an instance of the importance of such scientific researches in the ordinary business of life. Cassava and arrow-root are two species of fecula, nearly similar in appearance, use, and chemical properties; but they differ in their origin, in the place of production, and import duty; cassava being from foreign colonies, and therefore liable to a rate of 20s. per cwt., while arrow-root, being from our own colonies, is admitted at the rate of 1s. per cwt. A few months ago I was professionally called upon to give an opinion on an article, entered under the name of arrow-root, which was suspected, from the port it was shipped at, to be cassava. I placed a little of it under the microscope, and demonstrated by ocular proof to an Hon. Commissioner, and to one of the surveyors-general of H. M. Customs, that it was cassava, because it consisted of minute *spherical* particles in clusters, while I showed them in the same way that arrow-root consisted of separate truncated ovoid particles of nearly double the size. The evidence was irresistibly clear.

Fig. 9.

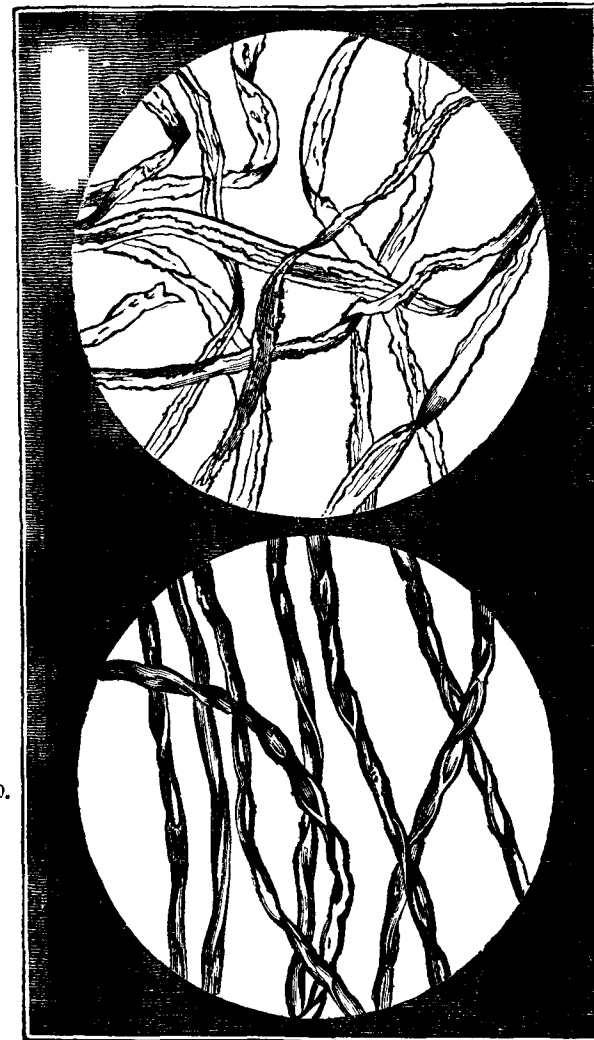

Fig. 10.

Fig. 9.—Religious Cotton, of which threads are worn by the Brahmuns.—It has a very flimsy fibre.

Fig. 10.—Best Sea Island Cotton, of which lace and fine muslin are made.—Fibres  $\frac{1}{2000}$  of an inch;—tortuous semi-cylinders of uniform size.

they will hardly pretend to decypher by its means the minute cross lines of flax or of wool. If such an instrument, when used with no common perspicacity and patience, led Lewenhoeck to describe the filaments of cotton as being all triangular, with fine sharp edges, and therefore very irritating when applied to ulcers, to what errors may it not give birth, with common hands and eyes! When I find a microscopic observer so justly celebrated as Mr. Bauer, representing both the fibres of flax and cotton under forms which I cannot help regarding as erroneous, I must own that my faith in minute philosophy is impaired. I offer this remark with the less hesitation, as I have verified the results derived from my own instrument with regard to cotton, by a comparison with those obtained from an excellent achromatic microscope by Tully belonging to Mr. Bauerbank, as well as by a very fine one constructed by Mr. Powell of Somers Town. I entertain no doubt that Plæssl's microscope is of the most perfect kind, though it is probably not superior to Powell's, nor of Mr. Bauer's general skill in observation; but I conceive the nature of the medium in which his objects were placed for inspection, has affected their forms very considerably, by refracting or diffracting the light by which they were viewed.

Wool and silk, however, may be viewed with most advantage impasted in Canada balsam slightly thinned with oil of turpentine, for water does not assimilate well with their fibres, nor with their refracting power.

The filaments of wool so seen in a powerful achromatic microscope have somewhat of the appearance of a snake, with the edges of its scales turned out a little from the surface, so as to make the profile line of the

Fig. 11.

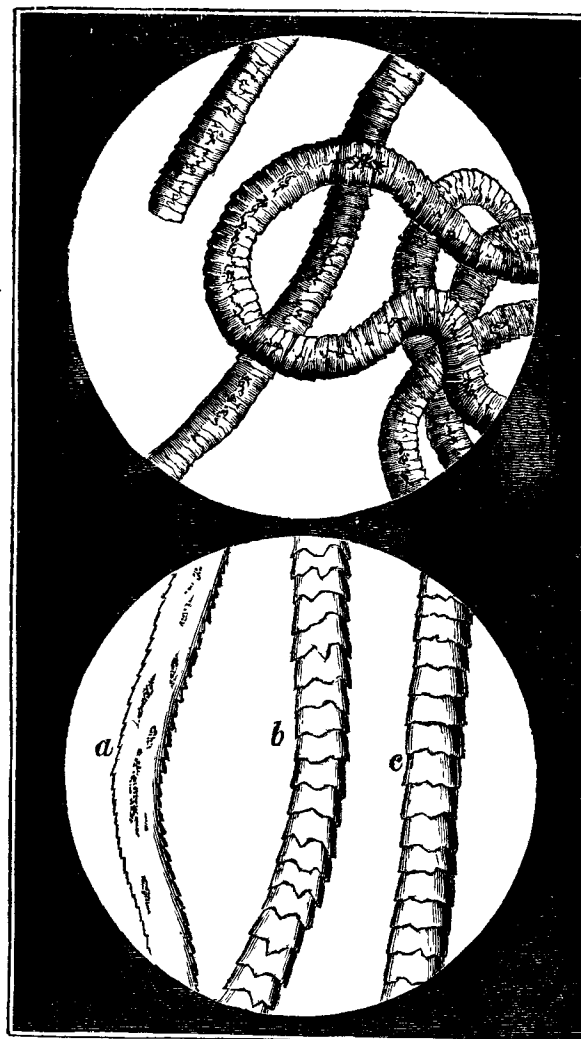

Fig. 12.

Fig. 11.—Australan Merino Wool.—Mr. Mc.Arthur's breed.  
 Fig. 12 —a, Leicestershire Wool; b, finest Saxony; c ditto Spanish.

sides look like a fine saw, with the teeth sloping in the direction from the roots to the points. Each fibre of wool seems to consist of serrated rings imbricated over each other, like the joints of equisetum. The teeth differ in size and prominence in different wools, as well as the annular spaces between them—the latter being in general from  $\frac{1}{2000}$  to  $\frac{1}{3000}$  of an inch, while the diameter of the filament itself may vary from  $\frac{1}{1000}$  to  $\frac{1}{1400}$ . The transverse lines resemble a little the wrinkles of an earth worm, but they are less regular in their course. Were a number of thimbles with uneven edges to be inserted in each other, a cylinder would result not dissimilar in outline from a filament of Spanish merino wool,—the fleece in which this texture is best developed. In the finest Saxony wool, the articulated appearance is also prominent, and of course the serrated profile of the edges. They are, likewise, well marked in Mr. M'Arthur's best long combing wool. In the Leicestershire long staple, the serrations are very minute, and the cross markings indistinct.

When the filament of wool is viewed in its dry state in a good microscope, it shows sometimes warty excrescences, but not (see fig. 13) the articulated texture, on account of the refraction and diffraction of light; though, when it is immersed in a thin stratum of turpentine, varnish, or oil, it exhibits these serrations most distinctly; but the warts vanish in the medium. This examination cannot be well made with even a good compound microscope of the ordinary construction; it requires for its satisfactory completion an achromatic instrument with a linear magnifying power of nearly 300. The felting property depends on the serrated mechanism, but is not

Fig. 13.

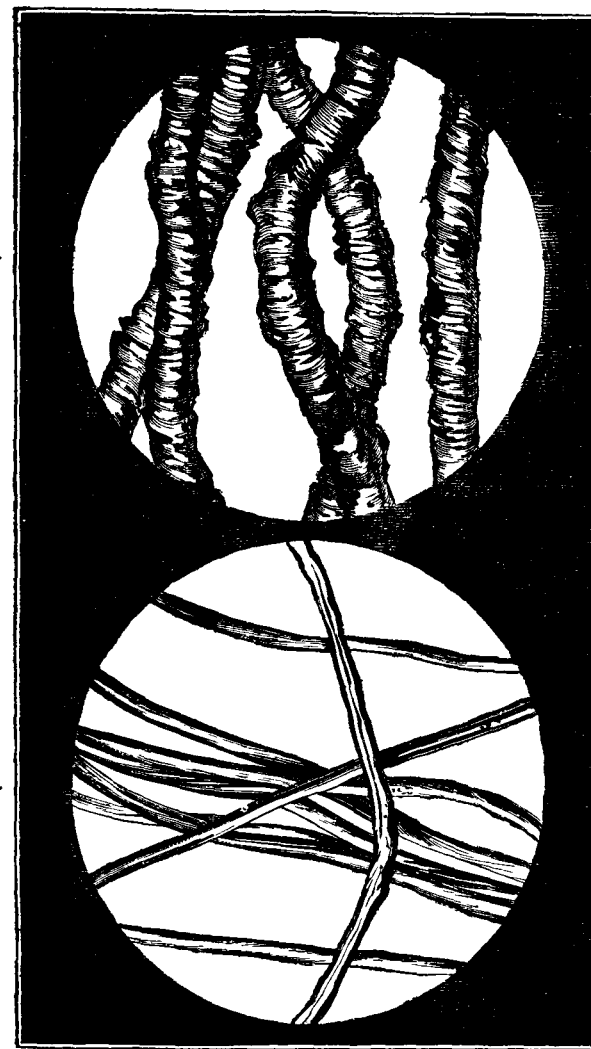

Fig. 14.

Fig. 13.—Wool, as seen alone.

Fig. 14.—Flax, as seen alone.

proportional to its development. The imbrications of the fibres lay hold on each other, as clicks do on ratchet teeth, so that when the wool is alternately compressed and relaxed in mass, they cause an intricate loco-motion among the filaments, urging them onwards till they become compacted into a solid tissue, called felt. In some specimens, the markings cross each other obliquely, with an appearance somewhat like the imbricated scales of pine-tops.

The cocoon-silk threads are twin tubes laid parallel in the act of spinning by the worm, and glued with more or less uniformity together by the varnish which covers their whole surface. Each filament of this thread varies in diameter from  $\frac{1}{1800}$  to  $\frac{1}{2300}$  of an inch, the average breadth of the pair being  $\frac{1}{1000}$ , but it is variable in different silks. The Fossombrone, worth from 22s. to 24s. per pound, consists of four cocoon threads, or of eight ultimate filaments, each of which is about  $\frac{1}{2000}$  of an inch, and the compound cord is equal to about  $\frac{1}{500}$ . The white Italian Bergam has its ultimate filaments so fine as  $\frac{1}{2300}$  of an inch. Different raw silks or singles appear in the microscope to vary considerably in the closeness and parallelism of the threads, a circumstance dependent partly on the quality of the cocoons and partly on the skill used in reeling them.

East Indian Comerolly single is loose in texture, consists of sixteen ultimate filaments, each about  $\frac{1}{2000}$  of an inch, and the cord at its most compact part has a diameter of  $\frac{1}{333}$  of an inch.

Turkey (Brutia) has a flaxen appearance, and consists of ten ultimate filaments, which form a cord of  $\frac{1}{333}$  of an inch.

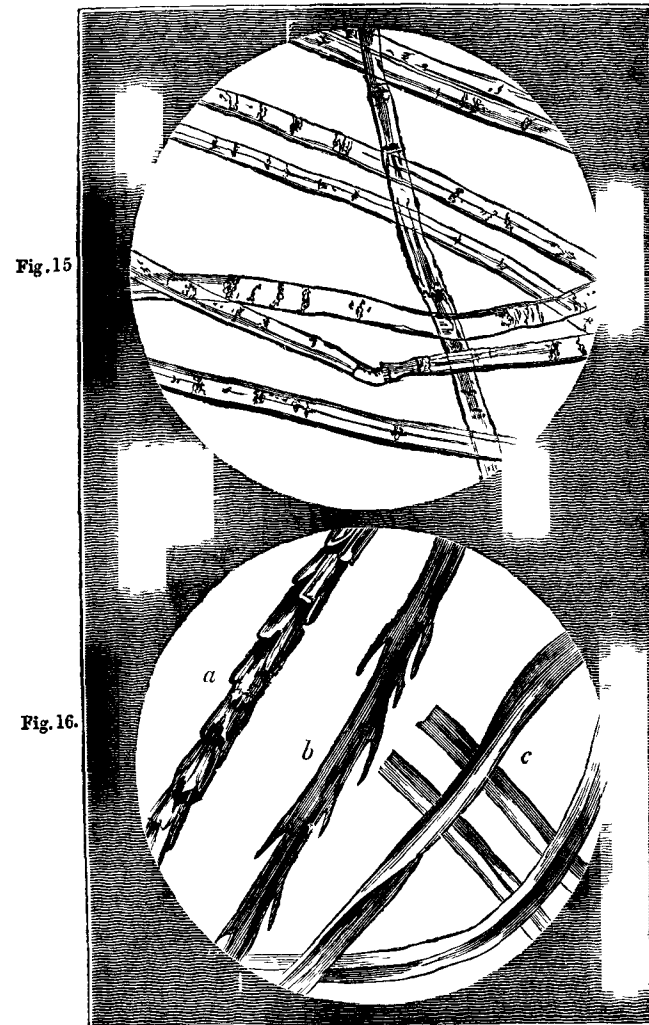

Fig. 15.

Fig. 16.

Fig. 15.—Flax, viewed by me in balsam.

Fig. 16.—*a*, hair of seal; *b*, hair of tiger-caterpillar; *c*, twin filaments of silk—all in balsam.

I have tried various modes of measuring microscopic objects, and give the preference, for very accurate purposes, to Troughton's eye-piece with parallel wires moved by a screw furnished with a graduated head. When this eye-piece is attached to my achromatic microscope, it enables a practised observer to measure easily the hundred-thousandth part of an inch. When a rougher estimate only is wanted, then Tully's slip of glass divided by the diamond into parallel lines  $\frac{1}{1000}$  of an inch asunder, of which I possess an admirable specimen, is a most convenient micrometer. It gives correct results to  $\frac{1}{5000}$  of an inch with an experienced eye. I concur in opinion with our distinguished naturalist Robert Brown, Esq., F.R.S., that micrometer measurements taken from the spectral image as seen projected upon a plane in the line of sight beyond or beneath the microscope, are apt to lead to great fallacies, from the effect of parallax. This method was extensively tried by me before employing the above two graduated instruments, but the discrepancies it occasioned in repetitions of the experiment on the same object, were so considerable as to make me give it up. Many of Raspail's measurements of the particles of different kinds of starch are erroneous from a similar cause.

The chemical composition of textile fibres was made the subject of experiments by me in the spring of 1822, and was described in my paper on the ultimate analysis of vegetable and animal substances, read before the Royal Society on June 27, and published in the Philosophical Transactions for that year. The constituents in 100 parts were as follows :

	Carbon.	Hydrogen.	Oxygen.	Azote.
Cotton-wool. . . . .	42·11	5·06	52·83	—
Flax. . . . .	42·81	5·50	51·70	—
Silk . . . . .	50·69	3·94	34·04	11·33
Wool. . . . .	53·7	2·80	31·2	12·3

Flax possesses nearly the same chemical constitution as sugar, for which reason it may be easily converted into sugar by trituration with sulphuric acid, and saturation of the acid with chalk.

Silk and wool are characterized like other animal matter, by the presence of azote in their composition.

Cotton when burned leaves one part in the hundred of incombustible ashes, consisting of 0.6 of soluble salts, chiefly carbonate of potash, with some muriate and sulphate of potash; and 0.4 of insoluble matter, phosphate and carbonate of lime, with phosphate of magnesia and red oxide of iron. The clean fleece of carded cotton was burned in a vessel of pure silver, and analyzed in vessels of platina and glass, so that the iron is a native element.

To ascertain with precision the specific gravity of textile fibres is a more troublesome experiment than would at first sight appear, and the point has for this reason probably been left hitherto undetermined. Having bestowed some pains upon the subject, and having contrived a simple method susceptible of giving exact results, I shall here state it in detail. I take a taper-necked phial, capable of holding nearly 2000 grains of distilled matter, poise it when so filled, mark the line of the neck where the water stands, and then pour out exactly 200 grains of the water. I next weigh out 300 grains of the textile substance, lay them on a clean tray, and proceed slowly to introduce them into the phial, in

harsh from the texture of the fibre itself, but from numerous warty excrescences which stick out all along its side. The finest wool of Mr. M'Arthur's growth, at 4s. per lb. has a glassy transparency, and is quite free from warts, even when viewed without varnish, like the best Saxon and Spanish wools. It is more uniform also in the size and shape of its cylinders than either of the two others. The average diameter of the Australian is  $\frac{1}{12000}$ , and in only a few is it  $\frac{1}{13000}$  of an inch. The Saxon at 5s. has several of  $\frac{1}{16000}$ , but others so large as  $\frac{1}{10000}$ ; and the Spanish at 3s. 6d. has the average diameter of the Australian, but not uniformly so, varying from  $\frac{1}{8000}$  to  $\frac{1}{13000}$ . Some of it appears warty when viewed in the microscope\*.

The smaller filaments of flax readily separate from each other when the fibres are delicately washed with hot water or a weak alkaline ley, or when a thread of white linen cloth is dissected by a needle point; they have an average diameter of  $\frac{1}{23000}$  of an inch; some however do not exceed  $\frac{1}{30000}$ . Different species of flax decompose into these minute fibrils with different degrees of facility; and thereby create different grades of value for the fine spinner. These filaments have a vitreous lustre similar to a capillary glass tube. They seem to be smooth, uniform, and free from joints when viewed in air, as represented in Fig. 13.

Fig. 7 of textile fibres represents Smyrna cotton, an irregular ribbon varying in breadth from  $\frac{1}{700}$  to  $\frac{1}{1200}$  of an inch. The straight lines seen crossing at right angles are those cut on Tully's glass micrometer, and

\* These samples of wools were obtained for me from the great wool-brokers Messrs. Loughnan and Hughes of Basinghall Street, through the favour of James Cook, Esq. of Mincing Lane.

are exactly  $\frac{1}{10000}$  of an inch asunder. Fig. 8 represents the fibres of Surat cotton, also very irregular, ribbon-like, and very variable in size. Fig. 9 exhibits the fibres of the *Gossypium religiosum*, of which threads are spun for the Brahmins to wear round their necks. I was indebted to Colonel Sykes for the specimen taken from his interesting herbarium of Indian plants. The cotton is extremely fine, but so filmy and frail as to require great pains to spin it. Fig. 10 shows a good specimen of Sea Island cotton, distinguished like all cottons of fine staple, by a semi-cylindrical and spiral structure; it is nearly uniform in the breadth of the filaments. The characters of the several varieties belong to the cotton manufacture. When cotton filaments are examined by a high power in a non-achromatic microscope, the bends of the semi-cylindrical ribbons look like empty spaces, and give the whole fibre the appearance of being a series of links.

The relative tenacities or strengths of several textile fibres has been experimentally found by suspending weights to threads or cords of them of a certain diameter. The following results were obtained:—Flax 1000; Hemp 1390; New Zealand Flax, 1996; Silk 2894.

The strength of cotton and wool has not been well ascertained, but it is much inferior to that of the preceding filaments. The New Zealand flax, which forms so strong a rope, is broken easily by angular flexure, and therefore does not form a durable canvass.

*On the different Modes of numbering Filaments, Yarns, and Threads, employed in Clothing Manufactories.*

The examination of a thread is not limited to its form or texture, but comprehends its colour, softness, hard-

ness, and strength. The measure of its strength is the weight requisite to break it, when suspended at one end, and loaded with a weight at the other. It has been found, that when the thread is cylindrical, or nearly so, it breaks under the same weight, whatever be its length. A convenient manner of making this measurement, is to tie the one end of the thread to the last link of a chain laid along a table, and to raise the other end till so many links are lifted off the table, as to effect the rupture of the thread. The weight, or number of links so lifted, will be equivalent to the strength of the thread. An ingenious mechanism, which registers the weights thus broken in the successive trials of the different portions of a thread, has been invented by Henry Houldsworth, Esq., of Manchester, which enables him to verify, with great readiness, the tenacity of his fine cotton yarn.

In cotton yarns, the rule of numbering is very simple, being the number of hanks, each eight hundred and forty yards long, requisite to form one pound in weight. Thus No. 40, written 40s., denotes yarns of which forty hanks weigh one pound. In France, a royal ordonnance, in 1819, directs that the *number* of cotton yarn should be reckoned by the number of kilometres contained in the weight of half a kilogramme. M. Molard, of the Academy of Sciences, was charged to explain this law by a table of instructions for comparing the old system of counts with the new. It is a matter of indifference whether the number of yarn be represented by the amount of given lengths of it in a pound, or in a half kilogramme, for the two weights are nearly the same; but the French have taken a unit of length inconveniently great, for showing moderate differences

of fineness. Their unit is upwards of thirteen hundred yards, while ours is only eight hundred and forty.

In the woollen manufacture, the French have established another system of numbering. At Sedan, the number of woollen-cloth yarn, indicates the number of hanks contained in a pound, *poids de marc*. The hank contains twenty-two *macques*, the *macque* twenty-two turns of the asple, and the asple 1,543 metres; whence it appears that the hank contains 1,493.6 metres. The ordinary numbers are 4,  $5\frac{1}{2}$ ,  $6\frac{1}{2}$ , 8.

Any one of these numbers, 8 for example, indicates that 8 hanks of yarn, No. 8, weigh one pound (*livre de marc*), which is agreeable to the English plan.

Long-wool yarns are numbered on the same principle; but their hank is shorter, being only 731 metres long, or somewhat less than one half the length of their hank of woollen cloth yarn.

#### FLAX-YARN.

The French reckon flax-yarn by the *quarter*, which contains  $12\frac{1}{2}$  *portées*; the *portée* contains 16 threads, each 16 ells long; whence it appears that the length of the quarter is 3,800 metres. The weight of the quarter denotes the fineness of the yarn. The English reckon by the number of hanks in a pound; 640 yards being a hank.

#### SILK-YARN.

The standard, or *titre* of silk measurement in Lyons, is expressed in deniers, or grains of the Montpellier pound weight, which contains 414.65 grammes, or 6,417.6 grains English. The unit of length is 400 ells, or 475 metres = 520 yards E.; and the thread



for trial being wound into a skein of this length, denotes by its weight in such grains the titre of the silk. The numbers most in use at Lyons, are:—

Ordinary organzine,	of from 25 to 30 deniers.	
Fine ditto	. . . . . 18	ditto.
Finest thrown silk for tulle	10	ditto.

*Matteau*, or paquet of white tram of two threads of grège silk . . . . . 24 26 ditto.

Grège silk is formed with four cocoon filaments.

The grain, or denier of Montpellier, according to Molard, weighs 45 milligrammes; and the pound contains 9216 grains. Hence the denier of Lyons would seem to be to the English grain used by goldsmiths, as 693 to 1000. I have found, however, by trial, that the denier in use among the silk manufacturers of London is equal to 0.83 of an English grain; or that 100 deniers weigh 83 grains.

In numbering cotton by the English method, as well as flax and silk by the French, the length of the thread is constant, and the weight denotes the number. For wool, the French plan is to take a constant weight of yarn, and reckon the number by its length.

## CHAPTER II.

*Nature, &c. of a Cotton Factory.*

THE art of spinning may be traced to the most remote antiquity, especially that by the distaff; and it is claimed as an honourable discovery by many nations. The Egyptians ascribe it to Isis, the Chinese to their emperor Yao, the Lydians to Arachne, the Greeks to Minerva, the Peruvians to Mamacella the wife of Manco Capac their first sovereign. The Greek and Roman authors attribute to their own nations respectively the invention of the spindle, as well as the art of weaving. Many writers of different countries give the honour of spinning to the fair sex; and the ancients, in particular, regarded this occupation as unworthy of men. It was under the infatuation of love that Hercules degraded himself by spinning at the feet of Omphale. Modern opinions have undergone a complete revolution with regard to this species of industry. A man is no longer deemed to be deserving of contempt for exercising the functions of a spinner; but what a superior result does he produce to that produced by Hercules! The Grecian demi-god, with all his talent, spun but a single thread at a time, while a Manchester operative spins nearly 2000. This art consists, philosophically speaking, in forming a flexible cylinder of greater or less diameter, and of indeterminate length, out of fine fibrils of vegetable or animal origin, arranged as

equably as possible, alongside and at the ends of each other, so that when twisted together, they may form an uniform continuous thread. Hence with very short filaments, like those of wool, cotton, and cachemire, a thread of the greatest length may be formed by torsion, possessed of nearly the sum of the cohesive forces of its elementary parts. Its size, or number, is measured by the area of the section perpendicular to its length; and this size is known to be variable or untrue, when equal lengths have different weights. Persons accustomed to deal in yarn can discover defects of this kind by mere inspection; but for accurate purposes they generally weigh a certain length of it. Its strength is easily estimated by the weight sustained by it; and this, as already stated, does not depend on the length of the specimen tried.

There is nothing in the history of commerce which can be compared with the wonderful progression of our cotton trade. Fifty years ago, the manufacture of woollens was the great staple of the country. In the year 1780, the whole export of manufactured cotton goods, of every description, amounted in value to only 355,000*l.* In 1785, two years after the American war, and when the commerce of this country had in some measure recovered from the difficulties under which it necessarily laboured during that conflict, the whole extent of our cotton exports, of every description, amounted to no more than 864,000*l.*; whilst, at the same period, the exports of woollen manufactured goods amounted to considerably more than four millions: the proportion between the two commodities being at that time in the proportion of one to five. From the last year up to 1822, incredible as it may

almost appear, the exports alone of manufactured cotton goods rose, by the official estimate, to the enormous amount of 33,337,000*l.*, being forty times greater than it was in the year 1785. But with respect to the woollen, the great staple trade of the country in former times, the exports in 1822 did not amount to more than 6,000,000*l.*, being not so much as one-fifth of those of cotton. Here we see what pre-eminent advantages arise from the principle of allowing capital to run in an open and unrestrained channel. The official value is no doubt higher than the real, but it is equally so for both branches. Mr. Huskisson stated in the House of Commons, on March 8, 1824, that according to the best information he had been able to obtain on the subject—and he said he had taken some pains to acquire it—he believed he was not overstating the fact, when he affirmed that the real value of cotton goods consumed at home within the last year amounted to 32,000,000*l.* sterling. Of these thirty-two millions' worth of goods, not more than six millions were invested in the raw material; and the remaining twenty-six millions went to the profits of the capitalist, and the income of the persons employed in the manufacture.

A great truth is here taught to the rulers of mankind. When they remove the restrictions and burdens from any particular branch of industry, they afford relief not only to the amount of the tax remitted, but lay the foundation for commercial enterprise, to an extent of benefit impossible to foresee. We may ask any man who has attentively considered the resources of this country, whether, if the restrictions had not been removed from the manufacture of cotton, this country could possibly have made the gigantic exertions which

it put forth during the late long war with the world, or could now pay the interest of the debt contracted in carrying on that war? We may also ask, whether the number of persons employed in this manufacture, to the amount probably of a million and a half, whose wants are supplied in return for their labour, does not afford more real encouragement to the agriculture of the country, than any regulation for keeping up artificial prices could possibly effect? It is to the increasing wealth of the manufacturing population, and the progress of creative industry, and not to artificial regulations for creating high prices, that this country must look not only for relief from her present burdens, but for the power of making fresh exertions whenever her position may demand them. The relief claimed for agriculture, by the landed aristocracy, cannot be given by any artificial measures, either to it or any other mode of occupation. It can flow only from the undisturbed and increasing industry of the people\*.

The most remarkable feature in the history of the cotton manufacture is the impetus which it has given to invention, the numerous valuable discoveries which it has brought forth, the ingenuity which it has called into action, the lights it has reflected, and the aids it has lent to the woollen, linen, and silk trades: the tendency and effect of all which have been to produce British goods at the lowest possible rate, and of a quality suited to every market, domestic and foreign. Each of these improvements, each corporeal transformation, so to speak, was attended at the time with some inconvenience to those engaged in the business, who were not in harmony with the movement; but the result has

\* Mr. Huskinson's Parliamentary speeches.

been, that not only has much more capital been beneficially invested in buildings and machinery, but a greater number of hands has been employed to occupy them, in proportion as the prospects of fresh resources were laid open to the manufacturer.

The details of the cotton trade, including a proper analysis of its operations, demand much ampler space than the limits of this volume allow; but such an outline of them may be given as will fill up our general view of the factory system. The perspective picture which fronts the title-page represents a cotton factory, recently erected at Stockport, on the most improved plan, and it will serve perfectly to illustrate the arrangement of the machines and concatenation of the processes.

The building consists of a main body, and two lateral wings; the former being three hundred feet long, and fifty feet wide; the latter projecting fifty-eight feet in front of the body. There are seven stories, including the attics. The moving power consists of two eighty-horse steam-engines, working rectangularly together, which are mounted with their great gearing-wheels on the ground-floor, at the end of the body opposite the spectator's right hand, and are separated by a strong wall from the rest of the building. This wall is perforated for the passage of the main horizontal shaft, which, by means of great bevil wheels, turns the main upright shaft, supported at its lower end in an immense pier of masonry, of which the largest stone weighs nearly five tons. The velocity of the piston in each of these unison engines is two hundred and forty feet per minute; which, by the balance beam, and main wheel, is made to give to the first

horizontal shaft 44.3 revolutions, and to the main upright shaft 58.84 revolutions per minute. As the one engine works with its maximum force, when the other works with its minimum, the two together cause an uniformity of impulsive power to pervade every arm throughout the factory, devoid of those vibratory alternations so injurious to delicate and finely-poised mechanisms. The engines make sixteen strokes per minute, of seven feet and six-tenths each, and perform their task with chronometric ease and punctuality.

The boilers for supplying steam to the engines, and to the warming-pipes of the building, are erected in an exterior building at the right-hand end of the mill; and transmit the smoke of their furnaces through a subterranean tunnel to the monumental-looking chimney on the picturesque knoll, shown in the drawing. By this means, a powerful furnace draught is obtained, corresponding to a height of fully three hundred feet.

As this mill spins warp yarn by throstles, weft yarn by mules, and weaves up both by power-looms, it exhibits in the collocation of its members an instructive specimen of the *philosophy of manufactures*. Both systems of spinning, namely, the continuous or by throstles, and the discontinuous or by mules, require the cotton to be prepared on the same system of machines; and therefore they must be both arranged subordinately to the *preparation rooms*. This arrangement has been considered in the true spirit of manufacturing economy by the engineer.

As the looms require the utmost stability, and an atmosphere rather humid than dry, they are placed on the ground-floor of the body of the building, as

also in a shed behind it, to the number of about one thousand. The throstle-frames occupy the first and second stories of the main building; the mules, the fourth and fifth stories; each of these four apartments forming a noble gallery, three hundred feet long by fifty wide, and twelve feet high. The third story is the preparation gallery, intermediate between the throstles and mules, as it is destined to supply both with materials. Towards one end of this floor are distributed the carding-engines; towards the middle, the drawing-machines for arranging the cotton fibres in parallel lines, and forming them into uniform slivers, or soft narrow ribands; and towards the other end, the bobbin and fly frames, or roving-machines, for converting the said slivers into slender porous cords, called rovings. These rovings are carried downstairs to be spun into warp-yarn on the throstles, and upstairs to be spun into weft (or sometimes warp) yarn on the mules.

The engine occupies an elevation of three stories at the right hand end of the mill. The stories immediately over it are devoted to the cleaning and lapping the cotton for the cards. Here are, 1. the willows for winnowing out the coarser impurities; 2. the blowing machine for thoroughly opening out the cotton into clean individual fibres; and 3. the lapping machine, for converting these fibres into a broad soft fleece like wadding, and coiling the fleece into cylindrical rolls. These laps are carried to the contiguous carding-engines, and applied to their feed-aprons. The winding-machines, and a few mules, occupy the remaining apartments in the right wing. The attic story of the main building is appropriated to the machines for warping and dress-

ing the yarn for the power-looms. The other wing of the mill is occupied with the counting-house, store-rooms, and apartments for winding the cotton on the large bobbins used for the warping-frame.

A staircase is placed in the corner of each wing, which has a horse-shoe shape, in order to furnish, in its interior, the tunnel space of the teagle or hoist apparatus, for raising and lowering the workpeople and the goods from one floor to another.

The plan and sections of this finished model of mill architecture are replete with the finest lessons of practical mechanics. They will be represented in accurate engravings, and explained with suitable details in our treatise on the cotton trade.

It will not be inexpedient, however, to describe here the American saw-gin, the ingenious invention of Whitney, which has had so great a share in reducing the price of cotton wool, as also the processes of carding and drawing in some measure common to all the textile manufactures. The saw-gin has never, to my knowledge, been fully figured or explained in any work in our language, though if rightly made and applied, it would prove highly useful to our commerce in cleaning the cottons of Hindostan. The attempts made with it there have hitherto proved abortive from want of knowledge and skill.

The French Minister of Marine, with the view of encouraging the growth of cotton in Senegal, caused experiments to be made in Paris with a Carolina saw-gin imported from New York. In the first experiment, twenty-eight pounds of Senegal seed-cotton, in its native state, were used. The filaments of this species adhere loosely to the seeds. The machine was set

in motion, first by one man, and then by two men, for three-quarters of an hour, and it yielded a product of eight pounds of picked cotton, and nineteen pounds and a half of seeds. Half a pound of cotton fibres seem to have been dispersed through the apartment, causing an apparent waste, which would not be felt on the great scale. The second experiment was made on a Georgian cotton, which sticks strongly to the seeds. Two workmen cleared out, in a quarter of an hour, seven pounds of native cotton, and obtained five pounds of seeds, and nearly two pounds of cotton wool. The cotton, as it left the machine, appeared in a sound state, and so well opened, that it might have been carded without previous blowing or batting. The commissioners thought, however, that the saw-teeth of the gin, in tearing the fibres from the seeds, broke several of them, and thus injured the staple. The experienced American ginner avoids this evil.

From these experiments, it would appear, that two men, working ten hours a day, would obtain one hundred and six pounds of wool from the first kind of seed-cotton, and only ninety from the second. It may be remarked, also, that while one workman turns the machine, another can feed in the crude cotton, and gather the ginned wool into bags. The commissioners, thinking favourably of this machine, recommended its introduction into the French colonies.

The principal parts of the saw-gin are two cylinders, of different diameters, F H (figure 17), mounted in a wooden frame A, which are turned by means of a handle, fixed on the axis of a fly-wheel. Its endless band turns a large pulley on the other end of the saw-cylinder F, and a smaller one on the other end of the

brush-cylinder H, causing the latter to revolve most rapidly. On the wooden cylinder F, ten inches in diameter, are mounted, at the distance of three-quarters of an inch apart, fifty, sixty, or even a greater number of circular saws like I, of one foot diameter, which fit very exactly into grooves, cut an inch deep into the cylinder. Each saw is formed of two segments of a circle, made preferably of hammered sheet iron. The teeth should be very sharp. Opposite the interstices of the saws are flat bars of iron which form a parallel grating, of such a curvature, that the shoulder of the oblique-shaped tooth passes first, and then the point; whereby a tooth when bent resets itself, by rubbing against these grate-bars, instead of being broken off, as would happen, if the point of the saw entered first between them. Care must be taken to keep the saws turning in the middle of their proper intervals; for when they rub against the bars, they tear the cotton to pieces. The hollow cylinder or drum H is furnished with brushes *c c*, the hair ends of which ought to touch the saw-teeth, and carry off the cotton adhering to them. It turns in an opposite direction to the cylinder F, and with greater velocity.

The cotton, with its seeds, is thrown into the hopper L. The saw-discs I, as they turn, meet the cotton, catch its fibres with their teeth, and drag them within the grating, while the stripped seeds, which cannot enter, on account of the proximity of the bars to one another, fall on the inclined board M, by passing through the bottom N of the hopper, the aperture of which is regulated by an adjusting screw. The teeth, filled with the wool, after passing through the grating, meet the brushes *c* of the cylinder H, and deliver up their cot-

ton to it, which then falls on the inclined board O, and thence into the magazine P. A cover Q incloses the cylinders and the hopper, which may be turned up on its two hinges, for giving the machine a charge, and then let down before setting it in action. The axes of the cylinders should be fitted well into their collar-bearings, to prevent any lateral swagging, which would injure their operation. The dotted lines in the figure indicate the cover in its raised position.

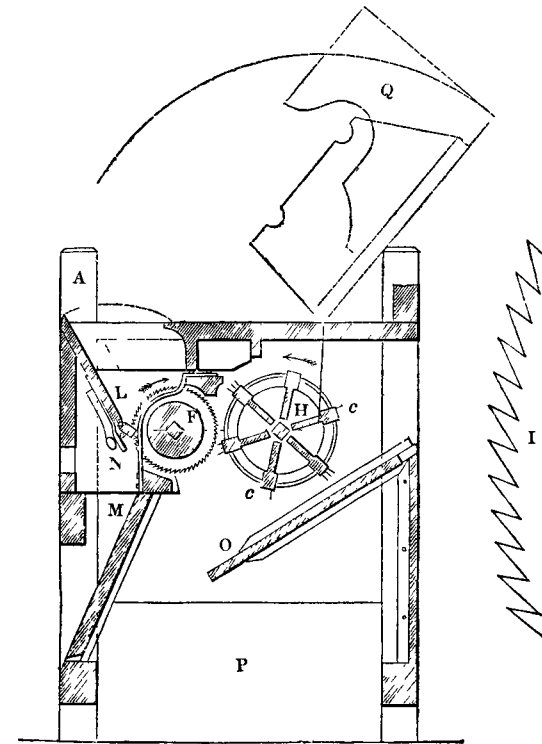

Fig. 17.—Whitney's Saw-gin.

Cards are instruments which serve to open up the filaments of cotton and sheep's wool, preparatory to their being spun. The fineness and equability of the spinning process, as well as the beauty of the stuff made from the yarn, depend very much on the regularity and perfection of the carding operation. In fact, an indifferent weaver will more easily turn off a piece of fine cloth, with well-made yarn, than a dexterous weaver could with that which has been ill prepared for spinning. Cards are made of bands of leather, pierced with a great many holes, having bent pieces of iron wire, called teeth, fixed into them. Each bit of wire bears two teeth. The leather, thus bristled, is then lapped round a cylinder, and fixed firmly to it by pins. The teeth should be uniform in size and shape, equally distributed, and stand at equal angles of inclination to the curved surface, conditions which cannot be expected from hand-work.

To judge of the difficulties of such manipulation, fig. 1 and fig. 2 need only be inspected. The wire must, first of all, be bent at right angles, at *a* and *b*; then each branch must receive a second bend, at *c* and *d*, at a determinate obtuse angle, which must be invariable for the same system of cards. It is indispensable that these two angles *a c e*, *b d f*, be mathematically equal, not only for the two conjoined points, but for the whole series of teeth; for if one of them slope more or less than its neighbour, it will lay hold of more or less cotton or wool, and render the carding irregular.

The perfect regularity of the teeth is an important matter, but it is not alone sufficient to constitute a good card. The teeth must be implanted, by pairs, in

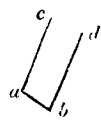

Fig. 1

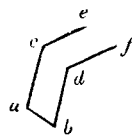

Fig. 2

its leather, and kept close to it by the cross part *ab*. The leather must therefore be pierced with twin holes for each double tooth, at the distance *ab*, but in such a way that the inclination of these holes, in reference to the plane of the leather, be invariably the same; for otherwise the length of the teeth would vary with the angle of inclination, and spoil the card. A third condition, indispensable for obtaining the required regularity, is to have the leather of uniform thickness throughout its whole surface; for were it not so, in vain might the teeth have equal lengths, and be implanted at equal angles, as the difference of thickness in the leather would make them unequal, and cause them to operate in a most defective way. Hence machines have been contrived,—first, for splitting leather with extreme precision into equal layers; secondly, for piercing it with equal regularity; and thirdly, for cutting, bending, and fixing the wire teeth.

The card-making machine of Mr. Dyer, at Manchester, is one of the most complete automatons to which manufactures have given birth. It splits the leather, pierces it, forms the teeth, and implants them, with precision and rapidity. Curious strangers, who are permitted to inspect it, through the liberality of the proprietor, never fail to express delight and astonishment at its operation.

The drawing-frame is a most essential constituent of the spinning system, executing a task much too delicate and irksome for handicraft labour, and therefore does the highest honour to its inventor, Sir Richard Arkwright. It equalizes the riband delivered from the finishing card, and reduces it to one of smaller dimensions called a sliver, which it effects by uniting

many ribands into one, at the same time that it lays the fibres in parallel lines and attenuates the whole by a regular process of extension. The twin-roller mechanism, which was perfected at least, if not invented by Arkwright, derives its best illustration from the drawing-frame. This talented individual saw so clearly the great part which this machine played in cotton-spinning, that when bad yarn made its appearance in any one of his mills, he swore a loud oath, according to the vile fashion of the time, and ordered his people to look to their drawings, convinced that if *they* were right, every thing else would go well. It is only those who have deliberately studied the intricate train of operations in a spinning-factory who are qualified to appreciate the merit of so admirable a systematist as Arkwright; and they know the value of his drawing-frame far better than his invidious detractors.

The drawing of the sliver into parallel lines of filaments is effected by the joint action of upper and under rollers; the former being smooth and covered with leather; the latter being fluted lengthwise. Of such twin rollers, there are usually three in the same horizontal plane; of which the three under-rollers are driven by wheel-work with either two or three successive velocities, and carry round their incumbent weighted rollers by the effect of friction.

Fig. 18 represents a section of the working parts of one drawing-head; and fig. 19 shows how the top rollers are pressed upon the under ones. B is the strong roller-beam, on which are fixed several such drawing-heads; *a, b, c*, are the under-rollers, and *a', b', c'*, their respective top-rollers; the former turning

in brasses, on iron bearings *d*. The front-roller bearing *c* is fixed, but the bearings of the two other rollers may be shifted in grooves so as to cause the rollers to approach to, or recede from, each other, until the adjustment proper for the staple of the particular cotton is hit; and then the bearings are secured in that position by the clamp-screw *d*, acting on the edges of the slots in the sliding-bearers. This is a recent and valuable improvement in the construction of the drawing-machine; prior to which these two bearings were so connected as to move together, and to be adjustable only in common to the front one; whereas, on the new plan, each of the intervals between the three rollers may be increased or diminished at pleasure. The slot-piece *d*, adjusts the roller *a*, and a similar slot-piece, behind or on the other end, adjusts the roller *b*. The top-rollers are equal in length to the two fluted portions of the under-rollers; and they turn with their ends in bearings which are adjustable in like manner with the bearings of the under-rollers, as shown in the figure. In the middle of each of the top-roller pieces *a', b', c'*, there is a smooth neck, on which the brass-collets *e, f*, (fig. 19) rest, whence proceed the wires *h, h'*, suspending the weights *g, g*, (fig. 18.) In general, the two back rollers *a, b*, which move most slowly, are pressed down by a weight common to both, while the front roller is pressed down by a separate one. The three top-rollers are covered with a mahogany bar *i*, faced underneath with flannel, to wipe off any fibres which may adhere to the top-rollers. A similar bar *l* (fig. 19) about an inch thick and of the length of one head, also faced with flannel, is made to press upwards, by a slight weight *m*, against the two front under-rollers *b*,



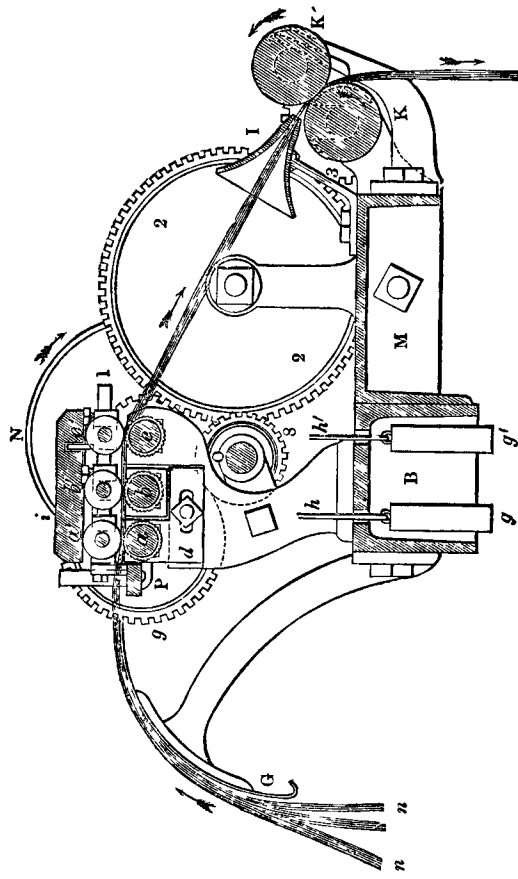

Fig. 18. - Section of a Drawing Head.

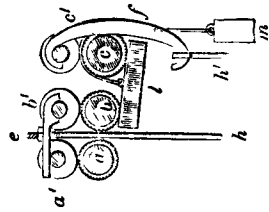

Fig. 19. - Drawing Rollers.

and *c*, to wipe them clean. In fig. 18, *G* represents a smooth curved brass or tin plate, along the surface of which the several slivers *n, n*, from their respective cylinder cans, placed at the back of the machine, are conducted to the rollers, being kept apart by pins, not visible in this view; whereby from three to six slivers may be brought together and united on one fluted portion of the rollers. This multiple sliver in passing between the triple roller series, especially by the action of the front pair, is drawn out into a much elongated and very thin sliver; of which two are generally brought together in the funnel *I*, and delivered by the two smooth rollers *K* and *K'*, into a can standing in the direction of the arrow in the front of the machine. Sometimes one of these slivers, just delivered, is returned over the smooth roller *K'*, and united with the slivers which enter the funnel of the adjoining drawing of the same head. The smooth roller *K* lies in bearings of the frame *M*, attached to the roller-beam *B*, which frame supports the funnel *I*. The top roller *K'* presses on the other by its own weight only, and is turned from the under one by toothed wheels on their ends, not seen in this view. This pair of long smooth rollers collects into one sliver the cotton fibres, which were spread between the drawing rollers *a, b, c*; wherefore it must travel with the same surface velocity as the front roller *c* does.

Since the surface of the front roller *c* must move very considerably quicker than that of the others, it is made somewhat larger, being from an inch and a quarter to an inch and three-eighths in diameter, while the others are only one inch; whereby it does not require a driving train of toothed wheel-work too much differing

in size from the rest. The surface velocity of the front roller *c*, is to that of the back roller *a*, in the proportion of from four to one, to six to one; and may be varied by changing the wheels on the ends of their axes, according to the degree of attenuation required in the sliver. The two back rollers *a* and *b* differ inconsiderably in their surface speed, generally not more than one-tenth, the middle roller *b* serving chiefly as a guide to conduct the fibres smoothly to the front roller.

It is the business of the attendant to mend or piece the feeding slivers *n, n*, whenever any of them fail or are broken, and to stop the machine, by sliding the drawing strap upon the loose pulley, whenever the delivery is in fault.

The first drawing-head unites eight card-ends into one, for the purpose of equalizing and extending the riband as well as laying its constituent fibres in parallel lines. The second and third drawing-heads go more slowly, they derive their supply of slivers from the first, and usually associate four of the slivers delivered by it into one. When a third drawing is given, seven of the last slivers are united; and when a fourth, fifth, and sixth are used, as sometimes for fine spinning, the doublings amount altogether to the product of  $8 \times 4 \times 7 \times 6 \times 6 \times 6 = 42,384$ . In spinning coarse yarns, such as 40s., three successive doublings, as they are termed, are reckoned sufficient: at the first, six slivers are incorporated into one; at the second, six into one; and at the third, nine into one—forming altogether the union of 324 slivers into the final sliver. In the subsequent preparation-machine, called the coarse bobbin and fly-frame, one pair of the drawing slivers

is associated into one roving, thus constituting a total doubling of the fibres 648 times, before they are taken to the mule or the throstle. In fine spinning, the doubling of the fibres is sometimes 70,000 fold—for the purpose of producing perfect uniformity in the finished yarn. From these facts, some idea may be formed of the important part which Arkwright's drawing-frame performs in a cotton-mill.

---

## CHAPTER III.

*Worsted Manufacture—General Observations on Wool.*

WOOL is the filamentous substance which covers the skins of sheep, and some other animals, as the beaver, the ostrich, the llama, the goats of Thibet, of Cachemir, &c. These varieties of wool serve for the manufacture of various stuffs and fabrics used for raiment and other purposes, under the name of broad cloths, kerseymeres, baizes, flannels, worsted stuffs, merinos, castorine, vigontines, cachemires, &c. Sheep's wool alone possesses the fulling or felting property.

Wools have been distinguished in commerce into two classes; fleece wools and dead wools. The first are obtained from the annual shearing of sheep; the last are those cut from dead animals, and are characterized by their harshness, weakness, and incapacity of taking a good dye, especially if the animal has perished from a malignant disease. In general, the best wools are those shorn towards the end of June or the beginning of July. Hence, on the sixth of this month, the celebrated sheep-shearing fête of Mr. Coke, of Holkham, is held.

Sheep's wool is greatly modified by the breeding of the animal; for it is a coarse hairy substance, mixed with a soft down close to the skin, on the wild *argali*, to which genus all the varieties of the domestic sheep have

been traced\*. That animal, and others with a similar coat, when placed in a temperate climate under the fostering care of man, lose their long rank hair, and retain the soft wool. Attention to the cultivation of fine wool has been long paid in many countries, and has produced the highly-valued merino species. It has been ascertained that the female has more influence than the male on the bodily form of an animal; but that the male, in sheep particularly, gives the peculiar character to the fleece. The produce of a breed from a coarse-woolled ewe and a fine-woolled ram will give a fleece approaching half-way to that of the male; and a breed from this progeny with a fine-woolled ram will yield a fleece differing by only one-fourth from that of the sire. By proceeding in the opposite ratio, the wool would rapidly degenerate into its primitive coarseness. Great care must therefore be taken to exclude from a breeding flock any accidental varieties of coarse-woolled rams.

Wools differ from each other in value, not only according to the coarseness and fineness, but also the length of their filaments. Long wool, called also combing wool, differs as materially in a manufacturing point of view from short or clothing wool, as flax does from cotton. Long wool varies in length from three to eight or ten inches; it is treated on a comb with long steel teeth, which open the fibres and arrange them horizontally like locks of flax, and such wool, when woven, is unfit for felting. Short wool varies in length from three to four inches; if longer, it is cut or broken to adapt it to the subsequent operations of carding and felting, in which the fibres are convoluted and matted together.

\* See note B at the end of the volume.

Among the long or combing wools, the shorter varieties are used principally for hosiery, and are spun into softer yarn than the longer varieties. The longer are manufactured into hard yarns for worsted pieces, such as waistcoats, carpets, bombazines, crapes, poplins, &c.

With regard to broad cloth, the finer, shorter, and to a certain degree softer the filaments of wool, the better the goods they make, because they accommodate themselves better to the fulling operation.

Short-stapled, or cloth-wool, is valued by the fineness, softness, soundness, density, uniformity, and whiteness of its fibres. These qualities are estimated with considerable accuracy by the cloth-manufacturer, wool-sorter, and wool-dealer, experienced by multiplied trials in discerning with the touch minute differences quite imperceptible to common observers, and not appreciable by the microscope. In the first chapter of this book, I have described certain methods of measuring the diameters of the fibres of wool with a microscope, provided with a micrometric glass plate, divided accurately by Tully into thousandth parts of an inch. The fibres are stretched gently across the graduated slip of glass, and kept in their place by a similar slip of glass laid over them, which is then fixed to the other by a slender clamp at each end. For very nice measurements Troughton's micrometer eye-piece, with parallel wires moved by a fine screw and graduated head, may be attached to the instrument. Thus equipped, it is capable of measuring pretty exactly the one hundred thousandth part of an inch.

The finest Saxon wool, at 5s. per pound, consists of filaments of  $\frac{1}{14000}$  of an inch in diameter.

A second Saxon wool, at 3s. per pound, measured  $\frac{1}{11000}$ , and was warty when viewed alone.

Spanish wool at 3s. 6d. varied in the diameter of its filaments from  $\frac{1}{11000}$  to  $\frac{1}{15000}$ .

A wool marked,  $\left. \begin{array}{l} I \ A \ E \\ L \end{array} \right\}$  Lot 12, varied from  $\frac{1}{7000}$  to  $\frac{1}{14000}$ , and was harsh to the feel.

The fibres of wool, viewed naked in a good achromatic microscope, have somewhat of a pearly lustre, and are covered with little rugosities, like pig's skin. The finer wools, viewed in balsam, show an annular arrangement. They are all tubular. The chief use of the microscopic observations of wool would seem to be the determination of the inequalities of size and form in one parcel. In good wools, the diameters of the filaments appear to be pretty uniform, and to be less than  $\frac{1}{10000}$  of an inch.

Four qualities are distinguishable in the fleece of the same animal. The finest is upon the spine from the neck to within six inches of the tail, including one-third of the breadth of the back or saddle. This kind is called by the Spaniards *floretta*. The second quality covers the flanks, and extends from the thighs to the shoulders. The third covers the neck and the rump; and the fourth lies upon the lower part of the neck and the breast down to the feet, as also upon a part of the shoulders, and the thighs to the bottom of the hind quarters. The Spaniards call this portion *cayda*. The sorting of these four qualities takes place immediately after the shearing, by tearing asunder the several portions, and throwing each into a particular bin.

Dividing Saxon wool into 20 parts, the assortment is—

2	from	6s. 6d.	to	7s. 6d.
6		3 6		4 6

6 from	2s. 3d.	to	2s. 6d.
6	1 8		2 6

The Austrian is a little lower.

The highest price of the best Saxony wool is 7s. or 8s.; but little of that quality is imported. One shilling a-pound, however, is of little consequence for the best qualities of broad cloths. It comes in washed in a superior manner.

The hardness of some of the English wools does not depend entirely on the race, or the climate, but on certain peculiarities in the soil which affect the pasture. The fleece of sheep fed on chalky districts is generally harsh; that of those fed on rich loamy argillaceous soil is distinguished for its softness. The Saxony sheep, being exposed to a less ardent sun than the Spanish, yield a softer fleece. The sheep pastured on the Cheviot hills in Cumberland, though not of the finest-woolled English breed, yield fleeces of remarkable softness, and have been refined still more by artificial means, particularly by smearing the sheep with an unguent, composed of tar and butter, immediately after shearing them. The felting property of wool is in some measure proportional to its softness, and depends conjointly on the annular and other rugosities of the filaments observable by means of a good microscope, and on their elasticity. In consequence of this structure, when they are pressed and rolled together, they become convoluted, and entangled by mutual friction. Heat and moisture favour the flexure and curling of the wool, which are essential to the matted texture. For this process, only the curling fibres are fitted, which continually change their directions in the fulling movements, and thereby interlace

themselves round other fibres. The furs of the hare, the rabbit, and the castor, being naturally straight, cannot be employed alone for felting, till they have acquired a curling texture at their points, by the application of nitrate of mercury,—an artifice called *secretage*.

The best length of staple for the clothing or fulling species of wool is from two to three inches. But Saxony wool, though four or five inches long, admits from its tenderness of being easily broken down by carding to the proper shortness, and is preferable, on account of its variable lengths, for making kerseymeres, pelisse-cloths, shawls, and such fabrics as require fine yarn.

The grease, or yolk of the fleece, is a species of soap secreted by the sheep, and consists of oil, with a little potash. Hence it serves to facilitate the scouring of wool by means of water alone, with which it forms a kind of sud or emulsion. It is most abundant in those breeds which grow the softest fleeces, and on the part of the back covered with the finest wool. This yolk, however, though favourable to the growing fleece, becomes injurious to it after it is shorn, and ought to be immediately removed, otherwise it will produce a fermentation in the wool heap, and render it hard and brittle, a change which takes place most rapidly in hot weather. Sometimes the fleece is washed with cold water on the animals before shearing; but when it is thick, as in the merino breed, it is washed after it is shorn, either with cold or hot water, the latter being most effectual, and is afterwards squeezed in a press to accelerate its drying. Wool loses, in this process, from thirty to forty-five per cent. of its weight. A Merino

sheep frequently yields from three to four pounds of pure wool, while the finest English fleece rarely weighs more than two pounds in the foul state, or a pound and a half when cleaned.

Long wool, called also carding wool, requires length and soundness in its staple, in order to admit of being spun in a way suitable for worsted fabrics. The fineness of the fibres, of the first consequence in the clothing wool, is of subordinate importance in the combing variety. There are two kinds of long wool: the one used in the manufacture of hard yarn for worsted pieces, the other in that of soft yarn for hosiery; the former being eight inches at least in length, the latter about four or five.

The rich pastures of England and of Belgium seem to be more favourable to the growth of long combing wool than any other country of the world hitherto tried; and they suit very well with the Lincolnshire and Leicestershire breeds of sheep. The average weight of a fleece being about eight pounds, renders the growth of such wool an object of importance to the farmer. For the general purposes of the worsted manufacture, this long-stapled fleece leaves nothing further to be sought after in British trade, and makes it an object of desire to other nations.

Of the origin of the worsted manufacture little is known, or the period when the comb was introduced in the treatment of long wools.

The long-woolled sheep of England are of four breeds: the Dishley, or new Leicestershire; the Lincolnshire; that of Tees Water, and of Dartmoor.

The Dishley wool has a staple about a foot in

length: it is very fine, and weighs eight pounds on an average of each fleece.

It is supposed that this peculiar product of our agricultural industry employs fifteen thousand looms, and is worked up into worsted goods worth three millions sterling.

The goats of Thibet, which furnish the fine shawl wool, grow it in the form of a soft down at the roots of their long coarse hair. The Angora goat also grows an extremely fine silky hair, often worked up along with silk into a peculiar style of goods.

The imported wools are almost entirely worked on the card; the finer kinds to be manufactured into cloth, the coarser into carpets. Of late years, a wool of the merino fleece has been grown to great advantage in New South Wales, and imported in great quantities. It is fully equal to the best Spanish merino.

The wool of the lamb is generally softer than that of the sheep from the same flock; and as it has the felting quality in a high degree, is much used in the hat manufacture. The wool of dead lamb-skins possesses less of the felting property, and is employed for flannels, and lamb's-wool hosiery.

Our races of short-woolled sheep are principally the Dorsetshire, Herefordshire, and Southdown.

We know little concerning the woollen manufactures of the Egyptians, Greeks, or Romans; but we may conclude that the latter nation had carried this important art to high perfection, from the great pains bestowed by them on the improvement of the breed of sheep, the high prices at which the fine-fleeced animals were sold, and from the large supplies of clothing sent to their armies. Woollen garments formed almost ex-

clusively the attire of the Romans, male and female, of every rank. After the downfall of their empire, the cloth manufacture, which had been with all the other arts of civilized life involved in a temporary ruin, began first to revive about the middle of the tenth century in the Low Countries, where it continued to bestow peculiar opulence, freedom, and consideration on the people for several hundred years.

In the middle ages Spain seems to have abounded in fine-woolled sheep, of the Tarentine breed, which it originally derived from its ancient Roman masters. So far back as 1243, the woollen cloth of Barcelona and Lerida is spoken of with admiration, and as being in high esteem at the gay court of Seville in the reign of Peter the Cruel. Innumerable flocks existed in Spain in the time of Charles V., of which so many as 30,000 belonged to one shepherd, and served to supply foreign nations with the softest wool. The finest wools then went to the Italian States, to the amount of many thousand sacks annually, at from forty to fifty gold ducats each; that is, from 10*l.* to 12*l.* of our present money. A coarser wool was exported to the Netherlands. The French were next in order to the Italians in manufacturing fine cloth, which they consumed partly at home, and exported to Turkey. In 1646, Nicholas Cadeau obtained a patent of twenty years for making, at Sedan, black and coloured cloths of the finest Spanish wool, like those of Holland; and thus laid the foundation of a local manufacture which has been famous ever since. Prior to their great revolution, the French excelled all the rest of Europe in the fabric, finish, colours, and softness of superfine broad-cloth.

Winchester, according to Camden, was the seat of a

cloth manufacture, under the rule of the Romans in Great Britain. But on their departure the arts also took flight, and left the English, for upwards of one thousand years, to clothe themselves in skins. Even George Fox, the founder of the Quakers in the reign of Charles I., travelled as a missionary through the country, buttoned up in a leathern doublet with sleeves, instead of a cloth coat; this being the common dress at the time of labouring mechanics, to which class this gifted individual belonged. History affords very scanty materials respecting the woollen manufactures of England prior to Edward III. That wise prince gave a new impulse to them by affording liberal protection to foreign merchants and artisans, who had been previously proscribed or molested by absurd enactments and prejudices. About this period Thomas Blanket and others set up looms in their houses at Bristol for weaving woollen stuffs, but were so harassed by the impositions of the mayor and bailiffs, that they were obliged to solicit letters from the king to permit them to exercise their calling without impediment, calumny, or exaction. In the year 1357, Blackwell Hall was appointed by the mayor and common council of London for a market, which was to receive the cloth goods exposed to sale. The statutes, in the following reigns, concerning the woollen manufacture, show that the manufacturers had now become a jealous body, desirous of imposing restrictions on the making and sale of goods to suit their own narrow interests.

During the reign of Henry VI., the exportation of woollen yarn was prohibited. Two *cloth-searchers* were appointed for every hundred throughout the realm, with authority to inspect and seal all cloth, even that made

in private families, which was sent to the fulling-mill, and to levy a penny on each piece. In the same reign, a reciprocity law ordained that “if our woollens were not received in Brabant, Holland, and Zealand, then the merchandize growing or wrought within the dominions of the Duke of Burgoine shall be prohibited in England, under pain of forfeiture.” It would hence appear that we were beginning to supply these countries with the kind of goods which we had been taught by their weavers to work only a century before.

About the year 1482, hats, made by felting wool, were introduced, instead of the caps in universal use before; but the hatters continued a small body in comparison of the cappers for a long time thereafter.

Among the sapient acts of the good old times may be mentioned the ordinance of Henry VII., declaring “that every retailer who should sell a yard of the finest scarlet-grained cloth above sixteen shillings, or a yard of any other coloured cloth above eleven shillings, was to forfeit forty shillings a yard for the same.” In the year 1493, this prince quarrelled with the archduke Philip, and thereby caused “an interruption of trade between the English and Flemish, which began to pinch the merchants of both nations very sore,” in the wise language of Lord Bacon.

Multitudes of eminent manufacturers were driven from the Netherlands to England by the Duke of Alba’s persecution of the Protestants, where they were graciously received by Queen Elizabeth, and obtained liberty to settle at Norwich, Colchester, Sandwich, Maidstone, and Southampton. These refugees contributed to improve our manufactures of worsted and light woollen goods, and to introduce the manufacture

of linens and silks, and probably extended the frame-knitting business. Elizabeth passed an act to relieve the counties of Somerset, Gloucester, and Wiltshire from the old oppressive statutes, which confined the making of cloth to corporate towns.

Alderman Cockayne and other London merchants had sufficient influence with James I. (whose kingcraft, like that of his predecessor, delighted in granting monopolies) to obtain the prohibition of the export of white cloths, and the exclusive privilege of *dressing* and *dyeing* cloths. In consequence of this preposterous act, the Germans and Dutch immediately prohibited the importation of dyed cloths from England, and thereby gave so great a check to our export trade in woollens, that in a few years it fell to one-third of its former amount. The wool was also depreciated by this measure from 70 to 80 per cent. After having inflicted much misery on the country by this disgraceful piece of legislation, the government at length took off the restrictions, and left the export of white cloth free.

The first act of parliament which absolutely prevented the exportation of wool by making it a felony, which could not be set aside by a royal license, is the 12th of Charles II., which was passed soon after the Restoration. To escape from this and other legislative shackles, Thomas Telham of Warwickshire, and two thousand manufacturers, left the kingdom, in the year 1665, and established woollen manufactures in the Palatinate, under the wise patronage of the Elector. They were soon thereafter reinforced by a band of manufacturers from Herefordshire.

It deserves particular notice, that during the pre-



valence of monopolies and protections, from the reign of Elizabeth to the year 1668, the woollen manufacture remained quite stationary in England, while it was making remarkable advances, both in quality and extent, in the neighbouring nations. In that year, however, Brewer with about fifty Walloons, came over to England, and received royal encouragement in the working and dyeing of fine cloths from Spanish wool alone, without admixture of inferior wool,—arts unknown to this nation before, and indeed declared to be impossible. They produced them 40 per cent. under their former price. The backwardness of England in this important branch of trade has been accounted for by Huet as follows :—“ It was owing to the municipal laws of England, and its usages towards strangers ; who, besides being doubly rated at the custom-house, were excluded from all companies or fraternities of trade ; and were not allowed to carry on manufactures as masters or partners, unless such as the natives were unacquainted with ; so that none of the Flemish master manufacturers of fine cloth went thither, theirs being a mystery not accounted new, though very much superior to the cloth-working then known in England. It was only those who worked in new kinds of worsteds, serges, damasks, or stockings, who went thither.”

In the year 1662, the Company of Merchant Adventurers declared, in a public memorial, that the white-clothing trade had abated from 100,000 pieces to 11,000 ! Such was the baneful result of impolitic legislation. An extremely foolish act of the lord-mayor and common-council of London was passed in 1678, “ for the regulating the cloth markets of the city, and for *preventing foreigners buying and selling !*” “ Fo-

reigners” is here a term of most exclusive import, as it denotes all persons not free of the corporation. This emanation of selfish fatuity prohibits the sale of all woollen cloths sent to London, except at three specified halls, amerces them in certain duties, and forbids their removal for three weeks, unless they were meantime sold to some draper or other freeman of the city. The door-keepers were to attend strictly at the halls, and turn out all foreigners and aliens coming to purchase cloth. They further ordained, that every freeman of the city who should introduce such a stranger into the halls should forfeit, for the first offence, five pounds—for the second, ten—and for the third, fifteen pounds !

That the commercial senate of the metropolis should pursue a policy so idiotic as to expel purchasers from their public markets, would be incredible at the present time, did we not hear strange sophistry still employed by certain city sages in favour of the most absurd systems of monopoly.

The American war gave a disastrous interruption to our old staple manufacture, and caused the price of wool to fall, towards its close, lower than ever it had been even when money was more valuable. A tod of twenty-eight pounds of the best Lincolnshire wool, for combing, fetched no more than nine shillings, and of the inferior kinds only six shillings, that is, from threepence to fourpence per pound weight.

It does not appear that for upwards of a century and a half any very essential alteration or improvement had been made in the *processes* of manufacture, either for woollen or worsted fabrics, beyond the variations of colours and patterns, accommodated

to the caprices of fashion. But fortunately for our clothiers, the ingenious mechanical inventions and arrangements of Arkwright, for the carding and spinning of cotton-wool, were soon modified to suit the two staples of sheep's wool, and produced an entire revolution in the woollen and worsted trade. Since this memorable era, the manufactures of heavy woollens and coarse worsted goods having been vitalized by mechanical power, have gradually expanded themselves in Yorkshire, Lancashire, and Gloucestershire, where, from the cheapness of living, the industrious spirit of the inhabitants, the abundance of coal and water-streams, they enjoy immense advantages over what they had possessed in mere hand-labour in the midland and western counties, where fuel is scarce. In the year 1738, the total number of pieces of broad and narrow cloths made in the West Riding of Yorkshire was under fifty-seven thousand. In 1817 it amounted to upwards of four hundred and eighty-three thousand, having increased nearly nine-fold, though our whole woollen exports were only doubled in the same interval. We thus see how the districts which were most forward in adapting mechanical inventions to the woollen trade have gained the ascendancy in the manufacture over the ancient localities. About the year 1782, the quantity of British wool unsold, in the hands of the farmers, was nearly equal to three years annual growths,—a quantity too large to have been consumed by our manufacturers, had not the introduction of machinery enabled them to work it up with much greater facility than in former times, when few masters used more than one pack per week each, instead of one hundred, a not unusual quantity now. Mr. John Brooke, of

Dewsbury, manufactures weekly about 110 packs of wool, in carpets and blankets, chiefly of the short-stapled foreign wool of moderate quality, because it is cheaper than the British. Under what a debt of gratitude have the agricultural interests been laid to the mechanical arts in this single branch of industry. How narrow must the mind of that landholder be who denounces and seeks to shackle factory labour.

In carpets, worsted yarn is used for the warps, and woollen yarn for the wefts. In Wilton carpeting, there is both a linen warp and a worsted warp.

Mr. Francis, of Heytesbury, Wiltshire, says, speaking of his own establishment in the year 1828, “the total quantity of our manufacture per week is 15,000 yards, and we are obliged to use entirely foreign wool, because the cloth made from the mixture of foreign and English sells so much less freely, and bears a less profit. The English clothing wool has altered for the worse in its quality for the last ten years. There is a difference of 1s. a yard between cloths made of the two wools at the same price. The English wool also wastes 5 lbs. in the score, and the other only 2½ lbs., by loss of animal grease.”

“I could not make an article that would be merchantable at all, except of foreign wool. I am of opinion that the French cloth is not superior to ours in the manufacture or the dyeing. The great importation of foreign wool has, in my opinion, aided the price of British wool; it has aided it in some instances by a mixture with it. We could not have executed the whole of an order unless we had had the two. We export eight parts of British to one of foreign in our own works. There is very little demand at home now

for British wool in clothing; but there is for it in blankets, bear-skins, and such articles\*.”

Hence, by the plan of mixture, much low English wools are consumed in our cloth manufacture, that would otherwise find no market at all.

The Prussians manufacture cloths with much address, and are our most powerful rivals.

The following interesting particulars are extracted from the Lords' Committee's Report on Wool, in 1828.

“A yard of army clothing costs about 4s.; and weighs, in its finished state, one pound ten ounces. Five pounds' sterling worth of wool is worked into twelve pounds and ten shillings worth of cloth. The cost of manufacturing finer cloth for gentlemen from their own wool, is 9s. a yard.

“Nap coatings at about 3s. weigh 14 ounces, and consume about 24 ounces of wool at 9d. per pound, per yard.

“Duffils weigh per yard one pound ten ounces, and consume 2¼ lbs. of wool, of low quality mixed with noils.

“Common worsted stuffs, made from long combing wool, cost 15s. or 16s. a piece of 28 yards. Merino gown and shawl pieces of 28 yards, cost about 34s. The former weigh about 2¼ ounces per yard; and consume about four times that weight of fleece-wool.

“About an ounce of indigo is requisite to dye a yard of army cloth; and to complete the blue dye, or the red with madder, costs 7d. per yard †.

“In consequence of the reduction of the duty on

\* Mr. B. Gott, of Leeds.—Committee of the Lords on Wool, 1828, p. 280.

† Mr. John Varley, Committee on Wool Trade, 1828.

foreign wool from 6d. to 1d. per lb. in 1824, and the speculating mania in 1825, the importation of German wool in these years glutted the market to such a degree that our short-stapled wool fell from 1s. 3d. to 7d., and the long-stapled from 1s. 2d. to 10d. In 1828 the prices began to rally, so that in 1833 Southdown wools fetched 1s. 2d.; our combing wools 1s. 4d.; and German wools, which had been so low as 1s. 6d., rose to 2s. 6d. Wools above 3s., however, have not advanced in price. The rise in foreign wools was owing, in a great measure, to the increase of the manufactures on the continent, especially in Belgium, and to the successful competition of the goods of the latter with the English in the Grecian Archipelago.

“Such has been the improvement in the course of the last twenty years in the quality of our best broad-cloths, that if a piece of Sheppard's celebrated imperial cloth were now brought into the market it would not sell. The processes of art are better understood, and are carried on with superior machinery, as will presently be shown. The cropping or shearing-machine was contrived by a gentleman of the name of Lewis, in Gloucestershire, the idea of it having been suggested by the sight of an American invention for the same purpose.

“There is no wool which spins so well as the improved Australian does, in consequence of the length of its staple, and its softness; and it has increased so much in quantity of late, that in the course of fifteen years it will probably suffice for the supply of all the import wool to our manufactures, to the exclusion of the Spanish and German wools\*. It is also better for

\* Mr. Henry Hughes, Committee on Manufactures of 1833, p. 78.

The first process to which the long wool is subjected, in a worsted factory, is washing, which is performed exclusively by men, with soap and water. They are paid by quantity, each man being attended by a boy, who receives the wool as it issues from between the two rollers in front of the washer, which squeeze out the greatest part of the moisture. The wool is then carried by the boy, in large baskets, to the drying-room, where it is spread upon the floor. The drying-room is generally placed over the boilers of the steam-engine, and is thus kept at a high temperature. The time during which the boy is exposed to this heat is inconsiderable.

After drying, the wool is removed to a machine called the plucker, which is always attended by a child, generally a boy of ten, twelve, or fourteen years. His business is to lay the tufts of wool pretty evenly, in an endless web, on an apron, which, as it travels forward, delivers the wool to a pair of spiked rollers, by which it is carried to the interior apparatus, which is somewhat similar to the willow employed in the cotton factories, and thence it is blown out at the opposite side. The use of this mechanism is to clean and straighten the fibres of the wool, and to prepare it for the next machine, the comb-card. In the old routine of the trade, and still for the finest description of work, the wool is not carded in the factory, but is given out to the wool-combers, who comb it by hand. This is very hard work, and is generally carried on in rooms which are close and hot, from their containing several stoves for keeping the combs at the high temperature, requisite to increase the pliancy and ductility of the filaments. Boys are not set to learn this trade at an early age.

Three implements are in common use for combing long wool:—1. a pair of combs for each workman; 2. a post, to which either of the combs can be fixed; and 3. a comb-pot or small stove, for heating the teeth of the combs. Each comb is composed of two rows of tapering pointed steel teeth, *c* and *b*, disposed in two parallel planes; of which one row is longer than the other. They are fixed into a wooden stock or head *c*, which is covered with horn, and has a handle *d* fixed into it, perpendicular to the planes of the teeth-range. The space between these planes is only one-third of an inch at the bottom of the teeth. The combs used for

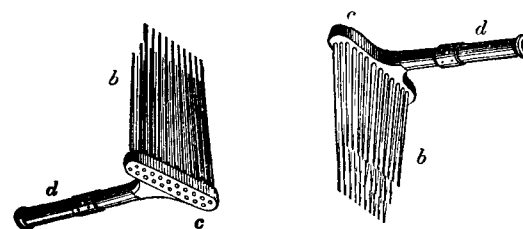

Fig. 20.—Long Wool Comb.

the last combing have three rows of teeth. In the workshop a post, fig. 21, is fixed, in order to support the combs occasionally during the process. An iron stem *g* is fixed into it, which has an upturned point, for passing through a hole of the handle of the comb, while it has a staple pin *h* at its inner end, for entering into the hollow extremity of the handle, and by the two fixtures holding it fast to the post. The stove consists of a flat iron plate, heated by a fire, or by steam, and surmounted by another plate, for confining the heat. Into a small space, left between the two plates, the teeth of the combs are introduced.

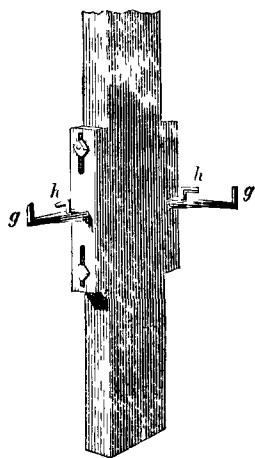

Fig. 21.—Comb Post.

In combing the wool, the workman separates it into handfuls, of about four ounces each, sprinkles it with oil, and rolls it up in his hands, to smear it uniformly. The proportion of oil varies from a fortieth to a sixteenth of the weight of the wool. Having fastened a heated comb to the post, with its teeth upwards, the workman takes one-half of that quantity of wool in his hand, and, throwing it over the points of the comb, draws it through them, and so repeatedly, a portion of wool remaining each time in the comb. When all the wool is gathered on the teeth, the comb is placed with its points in the stove, and the wool hanging on the outside receives a portion of the heat. The other comb, now hot, is fixed to the post, and filled, in its turn, with the other half of the four ounces of wool, and is then removed to the stove, like the first.

When both combs are properly warmed, the comber

holds one of them, with his left hand, over his knee, as he is seated on a low stool, and with the other comb, held in his right hand, he combs the wool upon the first, by introducing the points of the teeth of one comb into the wool contained in the other, and drawing them through it. This is repeated till the fibres are laid parallel. He always begins by introducing the points of the teeth of one comb first into the extremity of the fleece contained in the teeth of the other comb, and he then advances deeper at each succeeding stroke, till, eventually, he works the combs as closely together as possible without bringing their teeth into collision; otherwise he could not draw the comb through the wool without breaking its fibres, or tearing the wool out of the teeth of the comb. The short wool which remains on the teeth of the comb at last, because it does not reach the place where the comber grasps it, is called *noyl*, and is unfit for worsted spinning; it amounts to about an eighth of the new wool by weight.

The wool which is drawn off from the comb forms a continuous sliver or band, with straight parallel fibres, but is still not ready for the spinning-machine, till combed again at a somewhat lower temperature. When the process is complete, the wool is formed into parcels containing ten or eleven slivers each.

A great many self-acting machines have been contrived for performing the wool-combing operations. As the limits of this work do not allow me to give an historical account of them, I shall content myself with describing, briefly, one of the latest. It was made the subject of a patent by Mr. John Platt, of Salford, in November, 1827, being an invention communicated to

him by a foreigner residing abroad. This machine is intended to comb wool by means of two revolving combs or heckles. Figure 22 is a horizontal representation of the machine. It consists of a square frame of iron *a a*,

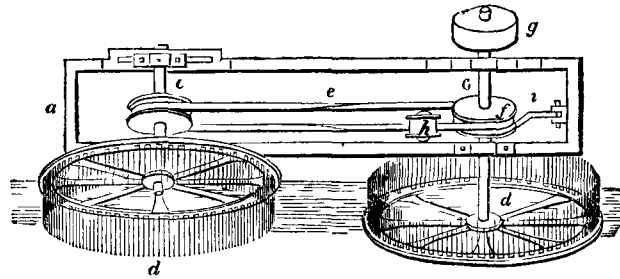

Fig. 22.—Platt's Wool Combing Machine

mounted upon legs, as exhibited in the end elevation, Fig. 23. *b* and *c* are two axles, upon each of which one of the circular combs *d d* is mounted. These axles, *b* and *c*, are not placed in horizontal posi-

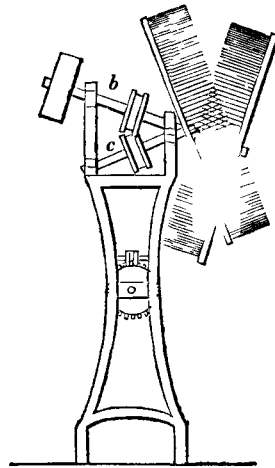

Fig. 23.—Platt's Wool-Combing Machine.

tions, but are inclined at acute angles to the horizon, and in directions crossing each other. The two circular combs, which are fixed upon these axles, consequently revolve in planes considerably inclined to the perpendicular, as well as to each other. These combs are made in the form of ordinary wheels, with arms, of which the nave is attached to the axle by screws. The points or teeth are set in the edge of the rim, at right angles to the axis of the wheel, and are made to revolve in opposite directions by means of a crossed or twisted strap *e e* running over a pulley *f* on each axle; these being driven by a band and rigger, or power-pulley, on the end of the axle *b*.

As the comb-wheels go round, they are made to approach each other slowly. This approach is caused by mounting the bearings of the axle *c* in slots, which allow of their sliding, and enable that axle and its circular comb to be brought towards the circular comb on the axle *b*. This traverse movement is effected by an endless screw and toothed-wheel, or snail-work, connected to the under part of the frame, as shewn at the centre of fig. 23. This mechanism gradually moves the axle *c* in a lateral direction, while the twisted strap *e*, which connects the two axles, and drives *c*, by the rotation of *b*, is kept at its proper tension, as the circular combs approach each other, by means of a heavy roller *h*, which hangs on a jointed lever *i*, fig. 22.

In putting this comb in operation, the proper quantity of wool, in its entangled state, is to be stuck between the teeth, and when the wheels are set in rapid rotatory motion, the loose ends of the fleece will, by the centrifugal force, be thrown out in the direction

of radii, and will catch against the points of the teeth of the other revolving comb, whereby the fibres will be drawn out and straightened. The operation is to commence when the comb-wheels are at their greatest distance apart. As they slowly approach each other, the ends or fibres of the wool will be laid hold of by the teeth-points, at progressively increasing depths, until the wheels come near together, by which time the whole length of the staple will have been combed out smooth, and will be then drawn from the comb, by throwing the driving-belt, as usual, on a loose pulley (not shown here). The *noyls*, or short refuse wool, which remains entangled among the teeth, being removed, the machine is charged for another operation.

Large machines of this kind are now at work in Leeds. In one of them the comb-wheels are ten feet in diameter, and are furnished with hollow iron spokes filled with steam, which keep the whole apparatus at a proper combing heat. These wheels are made to revolve slowly, while a boy, seated on the ground, dresses one of them with wool. They are then made to revolve with great rapidity, by shifting the driving-belt on the proper pulley, during which revolution they gradually approach each other. This being a work of simple superintendence, and not of effort and skill, like the hand-combing business, is now discharged by young children; and shows, in a striking point of view, the effect of automatic mechanism, in embodying handicraft dexterity and intelligence in a machine, and thereby substituting cheap and docile labour for what is dear, and sometimes refractory. Such machines will probably, ere long, supersede the hand-comb altogether. Care should be had to keep

the joints steam-tight, so as to prevent wetting the children employed at the machine, and to give due ventilation: for hot air, if pure, is not insalubrious.

The *breaking frame* is the next machine in the worsted manufacture, and is, in fact, a continuous form of comb or card, called by the French the *defeu-treur*, from its opening out any felted fibres. Fig. 24 represents a vertical section of a breaking comb, for the purpose of explaining the principles of its action. A B is a frame for carrying the machines, of which there are usually four alongside of one another, each from four to six inches broad. E is the front or feeding pair of rollers, three inches in diameter, the upper one bearing by a weight suspended to its axis on the under. F is the continuous lower comb, moving in the direction marked by the arrow *a*. G, the upper comb, going with the same velocity as the lower, in the direction indicated by the arrow *b*. The rows of teeth slope gently forwards, and alternate with the teeth of the other comb; thus the row of the one corresponds to the middle of the two other rows. H are fluted cylinders, which cause the rotation of the endless chain of combs. I, counter cylinders, fluted in like manner. The forked bearings in which these turn are so mounted as to permit the comb-chain to be stretched. K, small tension-cylinders, for giving a proper direction to each comb. L, the second pair of rollers, which takes the wool from the combs. These rollers are like the first, made of wood, and of the same diameter. The under one of this pair is kept clean by a brush. On its axis the fast and loose power pulleys are fixed, which give motion to the whole machine. The upper roller is furnished

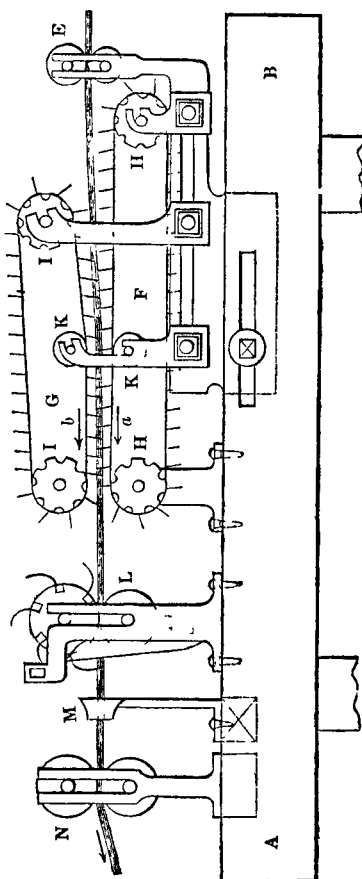

Fig. 24.—Worsted Spinning.

with wiper-wings; that is, its surface is covered with a series of small leaves of parchment, held by one of their edges with little clamps, or keys, in grooves cut lengthwise on their surface. The same cylinder is firmly pressed down on the lower one by a loaded steelyard.

The speed of the first pair of rollers is to that of the

second, as one to four, and the velocity of the comb-train is the geometrical mean between them, or two. Too great a velocity in these parts would be apt to knot and felt the wool; and it must not therefore exceed above five or six inches in a second. M is a copper funnel, or trumpet mouth, for conducting the sliver delivered by the second rollers. N, the third pair of rollers, turning with a little more velocity than the second pair, only in consequence of having a diameter a little greater.

The comb of this continuous machine is formed of a series of small rectangular pieces of tin-plate, hinged together, the half of one overlapping that of the other like slates on a roof, as is shown in figure 25 in double size. These pieces are struck out by a punch, which leaves at their four corners little discs *a, a*, which are afterwards bent back to a right angle by a

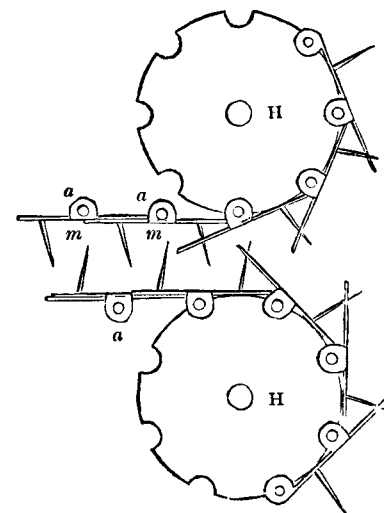

Fig. 25.—Machine for Wool Combing.



pair of plyers, and which serve to make the hinge joints, as is plainly shown in the figure. While the chain is advancing in a straight line, the teeth *m, m*, soldered to the lower tin-plate present the whole of their projection, minus the thickness of the upper plate, which is here cleft; but in proportion as these plates come upon the fluted cylinders H, fig. 25, which drive them, the plates cease to lie flat on each other, and become inclined by the curvature of the cylinders. The part cut through for the passage of the teeth recedes, or turns out of the way, and thereby passes by the extremities of the teeth *m, m*; thus getting disengaged from the fibres of the wool, and allowing them to be immediately seized by the second pair of rollers. In this way each piece of tin-plate acts both as a tooth and a disengaging bar. It is obvious that the upper and the lower combs, during their parallel progress, by means of their alternate rows of teeth passing between each other, like the fingers of our two hands, perform a double combing at a single stroke upon the cardings introduced in pairs at the feeding rollers. The rectangular figure (fig. 26) represents the whole breadth of

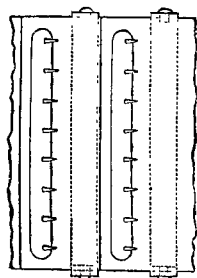

Fig. 26.—Hinge-pieces.

the tin piece, and the successive points where the teeth

are fixed into it, as well as the simple hinge mechanism.

The sliver delivered by the roller N, fig. 24, proceeds next to a large bobbin or cylinder, round which it is lapped, till the whole combing is entirely wound up. It is again passed through another chain-comb like the preceding, furnished with finer and closer-set teeth; and in this process the sliver is doubled, to give greater uniformity to the fleece.

The person who attends this machine, invariably a young boy or girl, is called the feeder. His business is to weigh the wool, and spread it in definite quantities on a travelling apron, which feeds the first pair of rollers. The attention of the feeder is necessarily invariable while the engine is at work, as the uniformity of the thread finally produced depends, in no small degree, on his accuracy. The film of wool, or open *drawing*, on its delivery from the last pair of rollers, is collected through a funnel mouth, and either lapped on a cylinder or received in a tin can, and broken off when the can is full. An empty can is then set in the place of the full one.

The machines for reducing, and at the same time equalizing, by doubling the *open drawings* of long wool, are constructed on the same principle as the drawing frame of a cotton-mill, only the distance between the first and last pair of rollers is much greater, on account of the greater length of the wool-staple. The drawing operation is performed by the first pair of rollers moving more slowly than the last pair, whereby the soft woolly riband is extended in length proportionally to that difference of velocity.

Hitherto, no degree of torsion has been given to the

slender fillet; but a little twist must now be introduced to preserve its cohesion, in its progression towards the state of a fine thread.

The following description of a roving apparatus for long wool will communicate a tolerably distinct idea of the process.

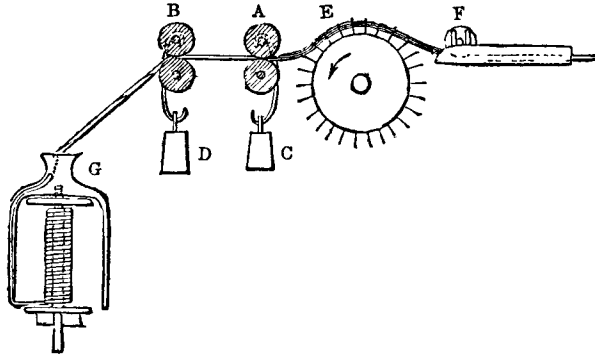

Fig. 27.—Worsted Roving.

A and B represent the sections of two pairs of rollers, the lower ones being made of iron, and fluted; the upper being of wood, covered with leather. Pressure is exercised by the upper on the under ones by means of the weights C D, suspended by curved rods from the ends of the axes of the upper rollers. The roller B moves faster than the roller A, in the proportion of  $2\frac{1}{2}$  or 3 to 1, according to the nature of the wool. The roller A rests on a moveable bearer, which permits it to be placed nearer to, or farther from, the roller B. E is a cylinder mounted with pins, which revolves very slowly on its axis, and delivers to the roller A, moving with a treble surface velocity, the open drawings of wool supplied by the feeding roller F. G is a spindle, having one leg of its forked flyer tubular, through which the roving passes in its way to the

bobbin. The spindle turns very slowly, so as to give no more twist to the filaments than may be necessary to secure the formation of an uniform soft cord during their extension. The up and down motion of the bobbin is given by an eccentric acting on the copping-rail, in a way which will be fully explained in treating of the cotton manufacture.

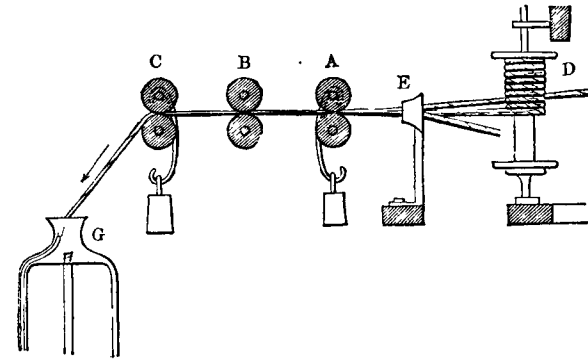

Fig. 28.—Worsted Spinning.

Fig. 28 is intended to explain the general manner of spinning long wool into a finer thread. Here are three pairs of drawing rollers, A, B, C; the first two of which are supported on moveable bearings, or brass bushes, which allow of their being separated, more or less, from one another, and also from the roller C, to suit the staple of the wool. The ratio of the speed of the first and last pair of rollers is as one to four. The roller B serves merely to bear up the fine roving; its velocity is therefore a mean between that of the other two. The bobbins filled with rovings made on the previously described machine, are arranged at D, behind the back-drawing roller A, in a creel-frame, so that three rovings together may pass

through the funnel or eyelet E, placed opposite the middle of this roller. The roving is never reduced to its ultimate fineness by passing through two or three such machines, but it passes successively through five or six of them, receiving not only extension, but an equalizing combination every time. At last, the fine yarn is formed by a spinning frame, or throstle, which may contain 254 spindles on each side, furnished with a four-fold set of drawing rollers. A popular conception of these may be obtained by inspecting fig. 29. The back and the front pairs of rollers A B alone are loaded by a suspended weighted lever D. The upper rollers of the two middle pairs E F are of lead, and press merely by their own weight. The ratio of the velocities of the extreme pairs of rollers is here as one is to six, eight, or ten, according to the fineness of the roving, and the number of yarn wanted. In this final spinning there is no doubling operation; but single bobbins are set on skewers in the reel in correspondence with the single spindles on the copping rail. The number of doublings in the process of drawing and roving long wool, may amount in certain cases to several thousand.

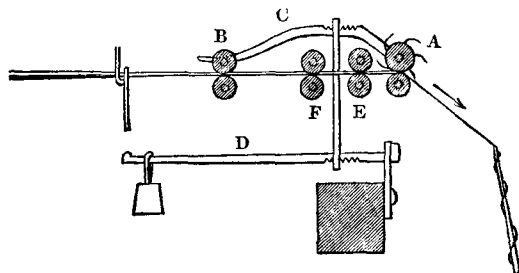

Fig. 29.—Worsted Throstle.

The spindles should revolve very quickly in the

spinning frame, in order to give the requisite degree of twist to the worsted. The hardest twisted worsted is called *tammy* warp; and when its fineness is such as to contain twenty-four hanks to the pound weight, the twist is about ten or twelve turns in every inch length. The least twist is given to the hosiery worsted yarn, which runs from eighteen to twenty-four hanks to the pound weight. The twist is only from five to six turns per inch. The degree of twist is regulated by the size of the wharves or whorls upon the spindles, and the speed of the front rollers, as will be fully explained in treating of cotton, in the spinning of which, on the fine mule, extraordinary nicety of adjustment is required.

A hank of worsted yarn contains five hundred and sixty yards; and it is divided into seven leys of eighty yards each. Some count hanks of eight hundred and forty yards, like those of cotton yarn.

The roving frames have much fewer spindles than the fine spinning frame; some of them are two spindle, some of them four spindle, others six spindle-frames, &c., which all repeat, however, the similar process of doubling threads and passing under drawing rollers, so as to give successive draughts to the spongy cords, and to maintain their perfect equality of texture. Girls, from sixteen to twenty and upwards, are generally employed at drawing, roving, and spinning frames. At the former two they earn from 6s. to 7s. each weekly; at the last, from 9s. to 10s.

## CHAPTER IV.

## NATURE AND OPERATIONS OF A WOOLLEN FACTORY.

*Of the Short Wool, or Cloth Manufacture.*

IN the structure and mechanical properties of its filaments, short or carding-wool resembles cotton very closely, and is therefore, throughout the spinning department at least, the object of similar machinery and manipulation. The great contractility and elasticity of the animal fibres, however, give to the cloth made of them a susceptibility for peculiar treatment by what is called the fulling, felting, and teasing operations.

The *wool-mill* or *willy* (called *willow*, in the cotton manufacture, probably a corruption of winnow) is the first machine to which clothing-wool is subjected. It opens up and cleans from sandy and other loose impurities the matted fleeces supplied by the wool-stapler. The most improved willy is the conical one, as now constructed by Mr. Lilly of Manchester, for opening out the staple of cotton as it comes from the bags. By the favour of this distinguished engineer, I shall be enabled to exhibit a correct delineation of all the essential parts of this very effective automatic apparatus. In the former willows used in cotton-mills, the cotton was introduced to the revolving spiked apparatus and removed by hand, not without risk of injury to the operator. Here, however, no such dan-

ger exists, for the wool, whether of the sheep or the cotton-plant, is continuously fed in at the one end by means of a travelling exterior apron, and given out by a similar mechanism at the other end. This facility of spontaneous circulation and discharge is derived from the conical form of the revolving drum.

The wool entering near the summit of the cone is at first subjected to the minimum rotatory impulsion of the machine, and is thenceforth continually solicited onwards, in the direction of the base, in obedience to the increasing centrifugal force. This cone is studded with rows of iron pins, and it revolves within a concentric case, studded with similar pins arranged alternately, so as to permit the former to pass through their intervals. When the wool has arrived by a spiral circulation near the base of the cone, it is deposited upon an endless apron, by whose motion it is turned out upon the floor of the apartment in a disentangled state. Fig. 30 exhibits a top view of this willow, with part of the casing and frame removed to show the interior structure. The cone *A* consists of a strong iron-shaft *a*, surmounted with three cast-iron rings, one at each end and one in the middle for supporting the sheet-iron mantle which forms the surface of the cone. Along this surface four equidistant iron-bars are fixed parallel to the axis, each of which receives a row of strong iron pins *b*, fixed perpendicularly by nuts and screws; corresponding with the intervals of these pins, are fixed also by nuts and screws a row of pins *d, d* on each side of the casing-frame. The top of the cone is covered in by a concentric envelop of thin sheet-iron, and its bottom is formed of a gridiron-plate also con-

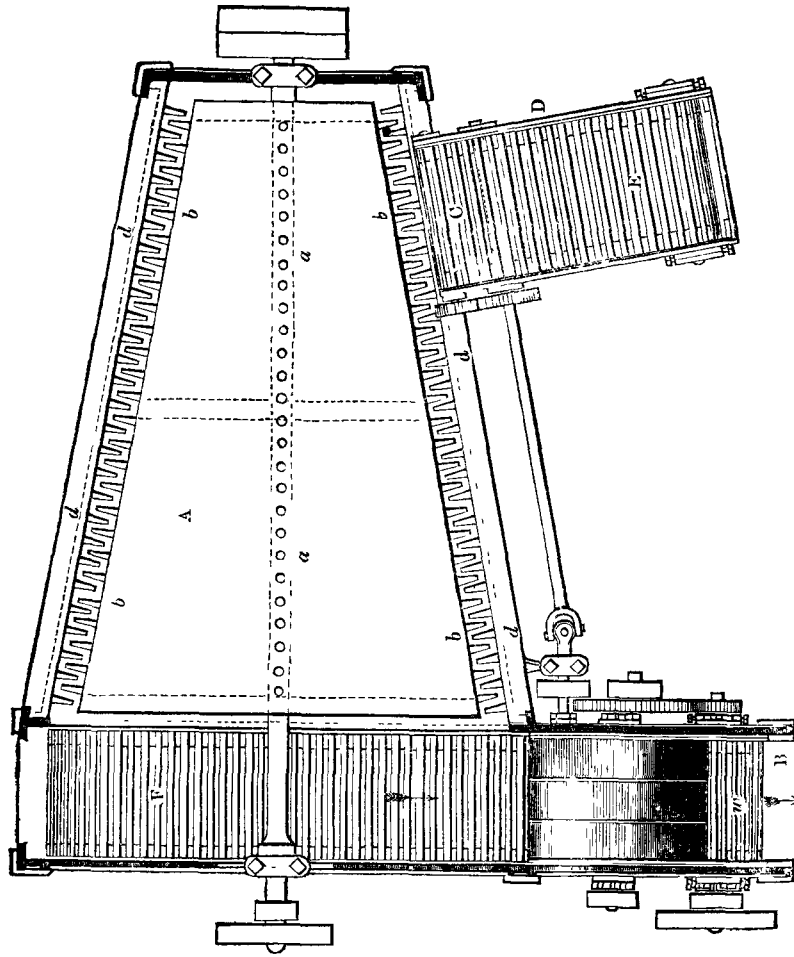

Fig. 30.—Lilly's Conical Willow.

centric. In the top casing near the narrow end there is an oblong opening C having a frame D attached to it, which carries an endless apron E. On this table or travelling apron the wool is spread by hand. The table consists of parallel slips of sheet-iron three-quarters of an inch broad, with interstices between them of half an inch, rivetted at their ends upon two endless leather straps. These travel upon pulleys fixed on two shafts parallel to the iron slips, the one of the shafts being moved by wheel-work and the other being adjustable by set screws which act on the bearings of the shaft so as to tighten the strap.

At the wider end of the machine there is a chamber F into which the wool is tossed out of the cone, after performing its spiral revolutions, and is then received on an endless apron like the former, as shown in the figure. About an inch above the surface of this apron, a cylindrical wire-cage revolves on an axis parallel to the apron. It is enclosed in a casing of sheet-iron, which communicates at its side with the chamber F. Over this casing, within the frame-work of the machine, a fan is placed, enclosed in a similar case, which sucks out the dust through the wire or squirrel cage in the chamber F below it, and blows it out through a large pipe connected with an orifice not visible in this view. The wire-cage and the fan are placed in communication by a flat tin-plate cover or lid, which embraces the openings at one end of the axis of these two cylinders. The opposite ends of the fan and case are left open to draw the dust out of the room, and to ventilate it. The wire-cage not only prevents the fibres of cotton or wool from being wafted away with the lighter dust, but it

lays them down in a fleece by its rotation on the travelling apron. Two other figures are requisite for exhibiting the working geer of the machine, but these are reserved for the more minute details illustrative of the cotton manufacture.

The machine is here represented on the greatest scale, and is drawn correctly three-fourths of an inch to a foot. I saw one of them in action, which was capable of cleaning 3000 pounds weight of cotton-wool in twelve hours. The wool slowly fed in by the apron *E* is disentangled by the revolving spikes of the cone, aided by the centrifugal movement; and discharges at once its heavier impurities, such as twigs, dirt, and stones, through the perforated bottom, and the lighter ones through the cylindrical cage under the draught of the fan, into a large pipe, and thence into a separate dust-room of the factory. The cleaned fibres thereafter come forth on the apron at *w* in the direction of the arrow. The best speed of the revolving cone is about 500 turns per minute.

Sheep's wool for coarse goods is passed several times through the willow, first to break the mats of the raw wool and to render it light; then a second time after it is dyed; a third time to mix the different sorts together, and a fourth time with the view of incorporating the oil thoroughly with the woollen fibres.

Blowing and lapping machines of curious structure are universally employed for cleaning and opening cotton after it has passed through the willow, before submitting it to the cards. But these refined mechanisms do not seem to have been introduced into the general run of the woollen manufacture, though they

will probably be adopted to a certain extent when their nature and merits become better known; a result which may in some measure be promoted by the delineations and descriptions of them prepared for the second portion of the present work.

*Scribbling* is merely a rude species of carding the oiled wool, and is the next process in the woollen manufacture. The scribbling machine delivers its wool in the form of a broad thin fleece or lap, and therefore corresponds exactly to the breaker-cards in a cotton-mill. This lap is then presented to the cards properly called, which work it again, and deliver it in a narrow band or sliver. A view and description of one of these machines will therefore serve to explain the structure and operation of both. Carding opens up and separates the woolly filaments, renders the fleece lighter, more equable, and homogeneous; it occasionally breaks the fibres in disentangling their connexions, multiplies their fibrils, and by giving them a bristling and downy texture, renders them more disposed to agglomerate in the fulling process.

By carding, wool expands greatly in its dimensions; the short broken filaments get crossed in every possible direction and are ready to lay hold of one another; constituting the most favourable conditions for being fullled. As the fibres of wool are more tortuous, elastic, and stiffer than those of cotton, they require in their carding apparatus not merely a main cylinder with card teeth, but a series of smaller ones riding upon and embracing it, for alternately taking off and returning the wool, so as to open it sufficiently without breaking it to pieces, and to lay the fibres at every imaginable angle to each other. Yarn made of

wool thus carded becomes susceptible of entering into a coherent combination, and forms at once a more ductile and more substantial thread, than yarn from wool which has been carded by hand.

The wool-carding engine represented in fig. 31 consists of several smaller cylinders covered with card cloth grouped round a larger cylinder A similarly

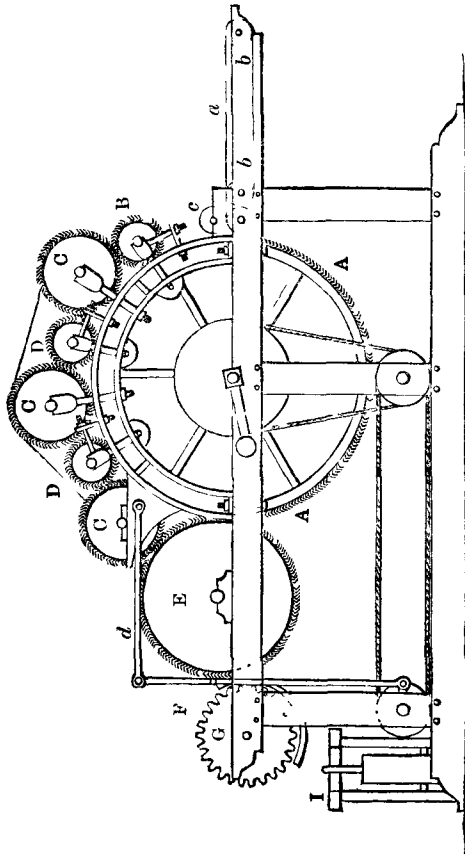

Fig. 31.—Woolen Card-Engine.

covered, which is about thirty-six inches in diameter, and thirty-two inches long. The wool is first laid down and spread evenly by hand upon an endless apron *a*, stretched between two rollers *b, b*, which by their rotation gradually move forwards the cloth and introduce the flocks of wool upon it between the pair of feed-rollers *c, c*, by which it is seized and distributed upon the first cylinder-card B, and from it transferred to the card-drum A. The drum is surmounted by three other pairs of cylinders of smaller diameters, which take successive shares in the carding operation. Each pair of cylinders consists of a *worker C*, and a *cleaner D*, somewhat less in size than its fellow, and turning in the reverse direction of the drum. The teeth of the first *worker* strip the wool from the surface of the drum, and then give it up to the *cleaner*, which, revolving with much greater rapidity, returns it to the drum-card. Hereupon the second working cylinder takes possession of the wool thus deposited, and turns it over to its attendant cleaner, whence it is again given up to the drum, and thus in continual succession. It is therefore by this repeated transfer from one cylinder-card or urchin to another, and by a continual drawing out between the teeth of the different orders of cards, that the filaments become separated and expanded. Pulled about, turned, and returned in every way, they get mixed and confounded together at one moment, to be disentangled at another, in order to form a light and homogeneous fleece. The teeth of the several cylinders do not come into actual contact, but they work so closely that they strip each other, time-about, of every adhering filament in regular succession.

When the fibres have been thus thoroughly teased out by three and sometimes four pairs of urchin cylinders, they are finally taken off the main drum by the stripping-cylinder E, called the *doffer*, which is of a smaller size and turns more slowly. The wool is taken off the doffer by a steel comb F, or doffing-knife, moved rapidly up and down by a crank, so as to give a shaving stroke to the surface of the card only in its descent, and thus to take off the card-teeth a continuous fleecy web of extreme tenuity. In the scribbling process this fleece is wound upon the surface of a revolving roller into the form of a lap.

In this lap, however, the fibres of the wool are seldom sufficiently disentangled. Several little knots and convoluted flocks may be perceived which this primary carding has not been able to undo. A second operation is therefore performed on the same wool by the same machine, and if necessary even a third.

The finisher or roll-carding-engine differs from the scribbler in several particulars. The doffing-cylinder, instead of having its surface completely covered with card-fillets in a spiral form, has merely a succession of oblong card-leathers fixed on it at intervals, parallel to the axis, so that the wool is detached from the doffer by the comb, in the shape of thin narrow bands of fleece, nearly as long as the cylinder. Each of these fleecy stripes is formed afterwards into a roll, by being rubbed round in succession by a fluted cylinder called the *roller-bowl*, encased at its lower and back part within a segment of a hollow cylinder called the *shell*. The fleece, being slowly rolled about in the small space between these two cylinders, takes naturally a cylindrical shape, and is turned out in

rolls called *cardings*, upon an endless cloth placed in front of and beneath the fluted cylinder. This finisher carding-engine is furnished with finer teeth than the scribbler. All the parts of the carding-machines derive their movements from a main axis, driven by a power pulley, as will be fully shown in analyzing the structure of cotton carding-engines. The wool card-drum makes about one hundred revolutions per minute; but the cotton-cards revolve far more rapidly. The surface of the working cylinders moves in the same direction as that of the drum, but much more slowly; the proportion being such that the *workers* make only one turn for every ten turns of the drum; and as they are about eight inches in diameter, their surface moves forty-five times less quickly than that of the drum.

The *cleaners* are so placed as to card the wool both on the *workers* and on the drum: they revolve very quickly, and take the wool from the workers, so as to clean it effectually; but their surface does not move so rapidly as that of the drum; for though they make three turns for every one of the drum, as they are only four inches in diameter, their surface moves about three times more slowly than that of the drum.

The last working-cylinder is called the *fly*, on account of its extreme velocity. Its surface turns in the same direction as that of the drum, but nearly one and a half times faster, its diameter being ten inches, and that of the driving-pulley, on its end, only three and a half inches. The fly is not set so near the drum as to be capable of taking the fibres from it, but only to tease them out among the teeth of the cards, and to raise them on the surface of the drum, to prepare them



for being easily stripped by the next cylinder—the doffer. For this reason the fly is furnished with straight teeth. The doffer turns very slowly, having a surface velocity of only one-thirtieth of that of the drum. It is fourteen inches in diameter, and receives motion from the same toothed wheel-work as the working cylinders. It is covered with rectangular pieces of card leather, about four inches broad. In the scribbler it is covered spirally with fillet cards, and the fleece taken from it either falls down into a bin, or is wound upon a wooden cylinder, about twenty-eight inches in diameter, turning with such a surface velocity as to coil on the lap no faster than it is taken off by the doffer-knife, for fear of stretching or tearing it. The doffer-knife is made to move up and down in an elliptic curve of about two inches in its longer axis, so as to strike and comb out the fibres from the card-teeth of the revolving cylinder. The teeth of the comb are about one-eighth of an inch long, and one-sixteenth of an inch apart.

On comparing the ancient plan of flat hand or stock cards with that of modern carding-engines, the advantages of the latter will be seen to consist not merely in economy of power and time, but also in a superior distribution of the woolly filaments. In fact, the workman carding by hand operates always in the same direction, and does not sufficiently intermingle the fibres, but brings them generally back to their primitive position; thereby giving the wool a less cohesive texture, and rendering it less fit for making strong yarns. By the use of carding cylinders the yarn becomes stronger, more readily woven, requires less dressing in

the warp, and the cloth made of it is therefore more easily scoured.

The scribbled wool is weighed, and a proper weight of it being taken to the finisher carding-engine, is spread over a certain length of the feeding cloth, so as to supply the wool to the feeding rollers with the utmost regularity. The proper weight is found out experimentally, and in correspondence to the quality of yarn required. The *cardings* are also weighed from time to time, to see that each contains the proper quantity of wool. They ought to be regular in texture and in size, to be converted into good rovings.

*The Slubbing Machine, or Billy*, performs the next operation. It reduces the cardings by drawing them out in length; joins them in a continuous spongy cord, giving them at the same time a slight twist, to maintain their cohesion and uniformity; and thus forms what is called a slubbing or roving—a soft thread to be thereafter spun, on the mule-jenny, into yarn fit for the loom. This operation was formerly done by hand, on a spinning-wheel similar to the common one for spinning wool, but of a smaller size. Machines were then contrived by which a number of cardings could be drawn out together; but the aid of the hands was required for joining the cardings of wool together in succession, which occasioned much loss of time and labour, and was therefore superseded by a special mechanism. Under the name of *Billy* this machine excited great interest during the recent investigations into the employments of factory children, and it therefore merits a particular description. Such slubbing is unknown in the worsted or long-wool as well as in the

cotton manufacture. It deserves to be noticed, moreover, as having been, in general, a non-automatic process, left very much at the mercy of the chief workman, to stand by or desert at his pleasure; and therefore it should bring no discredit on steam-driven machinery, since, were it so impelled, it would not be susceptible of causing that over-work to its juvenile attendants, with which it has been so loudly and not unjustly charged,—evils arising from the culpable irregularities of the adult slubber.

Fig. 31 is a perspective view of the slubbing-machine in common use. AA is the wooden frame; within which is the movable carriage DD, which runs upon the lower side rails at *aa*, on friction wheels 1, 2, to make it move easily backwards and forwards from one end of the frame to the other. The carriage contains a number of steel spindles, marked 3, 3, which receive a rapid motion from a long cylinder F, by means of separate cords passing round the pulley or whorl of each spindle. The cylinder F is a long drum of tin-plate, six inches in diameter, covered with paper, which extends across the whole breadth of the carriage. The spindles are placed in a frame so as to stand nearly upright, at about four inches apart: their lower ends are pointed conically, and turn in brass sockets called steps, and are retained in their position by a smaller collar of brass for each, which embraces the spindle about the middle of its length. The upper half of each spindle projects above the frame. The drum lies horizontally before the spindles, with its centre a little lower than the line of the whorls. The drum receives motion by a pulley at one end, with an endless band, from a wheel E, made like

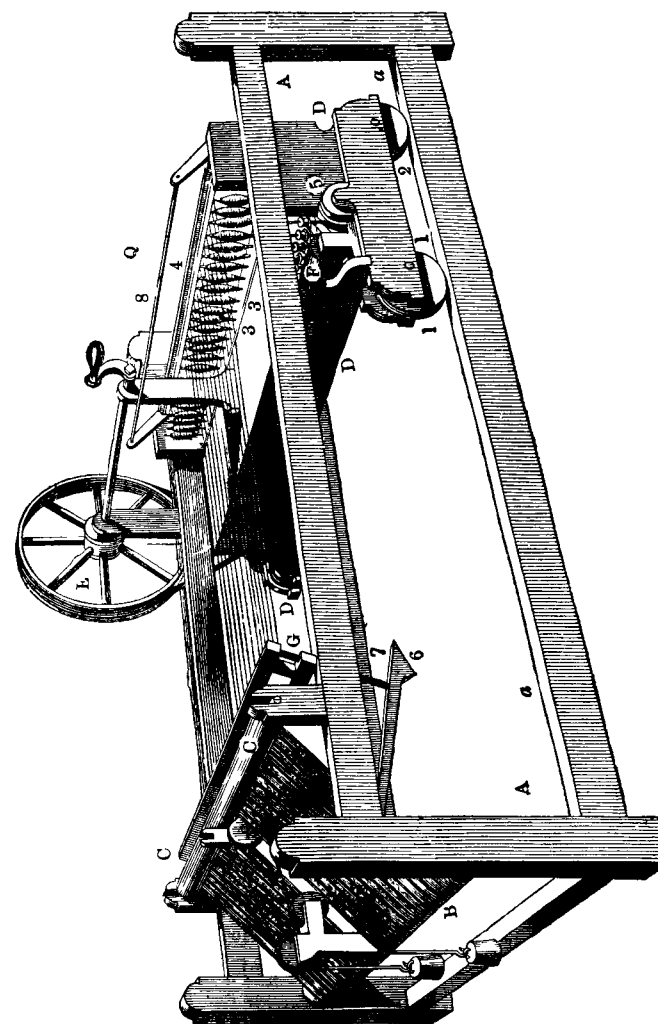

Fig. 31.—Slubbing Eully.

the large domestic wheel formerly used in spinning wool by hand, and of similar dimensions. The wheel is placed on the outside of the main frame of the machine, having its axle supported by upright standards, erected from the carriage D. The wheel is turned by the spinner, placed at Q, with his right hand applied to a winch (as plainly shown in the drawing), which gives motion to the drum, and thereby causes the spindles to revolve with great velocity.

Each spindle receives a soft cord or slubbing, which comes through beneath a wooden roller C C, at one end of the frame. This is the so much talked-of *Billy-roller*. The cords thence proceed to the row of spindles standing in the carriage, so that they are extended in nearly a horizontal direction. By the alternate movement of the carriage, the spindles are made to advance to, or recede from, the roller C, so as to extend any required length of slubbing.

The cardings of wool which are to be spun into slubbings are laid straight, side by side, upon an endless cloth, which is strained in a slanting position between two horizontal rollers, of which one B is shown in the figure. One carding is allotted to each spindle, and the number of spindles may vary from fifty to one hundred in one machine. The roller C rests on the cardings which move along the cloth, and, as it must press slightly, it is made of light wood. Immediately in front of this roller there is a horizontal wooden rail G, or long bar, with another beneath it, fixed horizontally across the frame. The carding is conducted between these two rails, the upper or moveable one being raised to let it through. When this bar is again let down, it pinches the carding fast; and

hence this cloven mechanism is called the clasp. It is precisely the clove originally used by Hargreave in his cotton-jenny. The upper or movable rail G is guided between sliders, and a wire 7 descends from it to a lever 6. When the carriage D is wheeled close home to the end of the machine, a wheel 5 lifts up the end 6 of the lever, and this, by the wire 7, raises the upper rail G so as to open the clasp, and release all the cardings. In this state of things, if the carriage be drawn back from the clasp-bar, it will necessarily pull the cardings forward on their inclined plane. There is a small catch which receives the upper bar G of the clasp, and keeps it from falling till the carriage has receded to a certain distance, and has drawn out about eight inches in length of the cardings: a stop on the carriage then comes against the catch and withdraws it, so as to allow the upper rail to fall and pinch the carding, while the carriage continues to recede, drawing out or stretching that portion of the roll which is between the clasp and the spindle. Meanwhile the wheel has been turned to keep the spindles in motion, and to give the proper twist to the cardings in proportion as they are extended, in order to prevent them from breaking.

It might be supposed that the slubbing threads would be apt to coil round the spindles, but as they proceed in a sloping direction from the clasp, they merely receive a twisting motion, always slipping over the points of the spindles without being wound upon them. Whenever the slubber has given a due degree of twist to the threads, he prepares to wind it upon the spindles in a conical shape, by pressing down with his left hand the faller-wire 8, so as to bear it away from

the points of the spindles and place it opposite to their middle part. He now causes the spindles to revolve, and at the same time pushes in the carriage slowly, so as to wind the slubbing upon the spindle into a conical cop.

The wire 8 is made to regulate the winding on of the whole row of slubbings at once, and is placed at the proper depression for this purpose by its connexion with the horizontal rail 4, which turns on pivots at its ends, in brasses fixed on the standards which rise from the carriage D. By turning this rail on its pivots the wire 8 is raised or lowered to any desired degree. The slubber seizing the rail 4 in his left hand thereby draws the carriage out; but on its return he depresses the faller-wire at the same time that he pushes the carriage before him.

As the cardings are exceedingly tender, they would readily draw out or break if they were dragged up the inclined plane. To save the necessity of this traction, a cord is applied round a groove in the middle part of the upper roller, and after passing over proper pulleys, as shown in the figure, it has a weight suspended at the one end, and another, but smaller, at the other; the small weight serves merely to keep the rope stretched, but the large weight tends to turn the rollers with their endless cloth or apron round in such a direction as to bring forward the cardings without putting any strain upon them. Every time that the carriage is pushed home, the large weight gets wound up by a piece of wood, which projects from the carriage, seizing a knot in the cord at the part which lies horizontally: this pushes the cord back a certain distance, so as to draw up the great weight; but the endless cloth cannot

return backwards, by reason of a ratchet and click at the end of one of its rollers: the rope therefore slips round upon the roller. When the carriage retires, the greater weight turns the roller, and advances the endless apron, so as to deliver the cardings at the same rate as the carriage, by coming out, takes them up; but when the proper quantity is delivered, the knot in the rope arrives at a fixed stop, which does not permit it to move any farther; and at the same instant the roller 5 quits the lever 6, and allows the upper rail G of the clasp to fall, and pinch the carding fast: the wheel E being then put in motion makes the spindles revolve, and the carriage being drawn out extends the slubbings, while under the influence of twisting. In winding up the slubbings the operative must take care to push in the carriage, and to turn the wheel round at such rates that the spindles will not take up faster than the carriage moves on its rail-way, or he would injure the slubbings.

A child attends the machine, who brings the cardings from the card-engine, and places them upon the inclined cloth between C and B; and he must be careful to join on fresh ones to the ends of those nearly exhausted. Slubbings intended for warp-yarn must be more twisted than those for weft; but they must also receive a degree of torsion relative to the quality of the wool and the cloth to be made with it. In general, it may be stated that no more twist is given to the slubbings than is indispensable to make them draw out to the required tenuity without breaking. This twist forms no part of that of the yarn, for the slubbing will be twisted in the contrary direction, when it is spun thereafter in the jenny. Instead of these hand-

machines, automatic stretching machines, like the stretching mules used in cotton manufactories, have been recently introduced into the woollen trade with the effect of making better work, and superseding the irregularities of the slubber, which operated sometimes most injuriously on his young assistants, as I shall hereafter describe.

The cardings, as fast as they fall from the carding-machine, are taken up by the children, called pieceners, from the nature of their work, being to piece or join those porous rolls together, to fit them for being drawn into a continuous thread. One slubber with one billy machine, containing on an average sixty spindles, is appointed to each carding-engine, and has in well-regulated factories four pieceners attached to him. These billys are, as we have shown, not driven by the steam-engine, and are worked within the factory merely because the card-engines are there. Hence the speed and continuance of their labour are entirely at the option of the slubbers. The billy is placed immediately opposite the carding-engine.

The business of the children is to take the cardings and lay them on the sloping billy-board, joining their ends by rolling them together for a moment with the palm of the hand. Each piecener having fifteen ends to piece, collects several cardings at once, which he lays over his left arm, and walks alongside of the billy, joining each end successively with his right hand. The part of the billy which contains the spindle-carriage is movable in a direction from the billy-board through what is called the *billy-gate*, a space of several feet. The slubber's drawings and windings on succeed each other at the rate of four or five in a minute; but

as at each drawing part only of the carding is pulled forwards, each child has ample time to piece his fifteen ends. He must take care not to stretch the cardings in lifting them up, and to join them evenly and effectually. If any fault is committed in this respect, it produces what the workman calls "flies" on the slubbing, or they are said to be "ratched cardings." If the child has neglected to join on every one of the ends by the time that the former cardings are drawn through, the ends are said to be "let up;" and when this happens, it occasions of course delay in the work.

Much of the cruelty complained of in factories takes place between the slubber and his pieceners. It is usual for the slubber to be provided with a strap, and if his young assistants let the ends up, or make an extraordinary number of "ratched cardings," he calls the delinquents round to the billy-gate at Q and straps them. The degree of the punishment depends of course more on the temper of the man than on the rules of the establishment. If he strikes the children with the billy-roller, which is easily removable from the frame, he will probably do it by reaching at them across the billy. But a practice prevails not unfrequently among the slubbers, by which, in fact, the children seem to suffer more at their hands than in consequence of working over-hours. The slubber, as already stated, being in his labour independent of the steam-engine or water-wheel, works his billy or not at his pleasure, as in general it is quite unconnected with the rest of the machinery. If he is disposed to leave his business for the pot-house at arbitrary intervals, as many handicraft tradesmen are too apt to do, for half an hour, an hour, or more, a great accumu-

lation of cardings from the power-driven carding-engine will ensue in his absence. The children pile these on the floor in heaps called *stacks*, of which they will sometimes have six or seven, containing from twenty dozen to forty dozen cardings in each stack. A rule is talked of for throwing the cards out of gear after six stacks are collected; but it can seldom be enforced against hands engaged in tyrannical unions. On the slubber's return from his voluntary absence, he usually sets to work much more violently than common, to clear his drinking score and to make up for lost time, as he is paid by the piece, or the *great* as he terms it. On such occasions the children are tasked to severe exertion, and are often capriciously punished by this *independent workman* for unavoidable faults of his own creation; for the children have not only to continue piling up the cardings incessantly thrown off by the carding-engine, but also to piecen their slubbing ends with double rapidity. Children are preferable as pieceners, not simply from the cheapness of their labour, and the mobility of their muscles, but from their size, as they can work without constraint at the billy-board, which must be kept low for the convenience of the slubber, and could not be properly served by taller persons without painful and injurious stooping.

It is obvious that this branch of the woollen manufacture permits the ill-treatment of children in consequence of its being detached from the steam-engine, being so far not a factory but a domestic employment, and therefore subject to the caprice of individual operatives. It is given in evidence that "the slubbers generally are a morose, ill-tempered set. Their pay

depends on the children's work. The slubbers are often off drinking, and then they must work harder to get the cardings up. I have seen that often. Mr. Gamble (the proprietor of the factory) is one of the most humane men that ever lived, by all that I hear, and he will not allow the slubbers to touch the children on any pretence; if they will not attend to their work he turns them away\*." It is, however, unhappily, of such consequence to poor parents to eke out their own earnings with that of their children, that they are often too willing to wink at their ill-usage by the slubbers who hire them, and to stifle their complaints. These operatives are described as unamiable, refractory spirits, requiring over-lookers of a determined temper to keep them in order, and they are often the fathers or guardians of their pieceners †.

The invention which forms the subject of Mr. Charles Wilson's patent, specified last December, is intended to supersede the necessity of employing the machine called the slubbing-billy, in preparing wool for spinning, and consists in the adaptation of certain pieces of mechanism as auxiliaries to an engine for scribbling or carding wool.

The wool having been scribbled in the ordinary way and deposited in loose untwisted bands in a series of receiving cans, as commonly practised, the first feature of the invention applies to the manner of feeding or conducting those bands from the cans into a second scribbling or carding-engine, which is done by leading those bands of sliver over a series of horizontal rollers mounted in a frame at the feeding-end of the engine, and by the rotation of these rollers, passing the bands

\* First Report of Factory Commissioners, C. 1, p. 10. † Ibid.

severally through distinct guides or eyes, and between rollers and partitions, in order that the bands of wool may not be indiscriminately mixed on the carding-cylinder, but that they may be carded in the same form for the purpose of being taken off at the doffer-end of the engine again in bands, and so conducted forward and wound in bands, as slubbings, on bobbins ready for the subsequent operations of mule or throstle-spinning.

The second feature is the adaptation of a cylinder with bands or ribs of cards round it, and intervening blanks, which cylinder is employed as a stripper in place of a doffing-comb, to take off or strip the slivers of wool from the doffing-cylinder in the same form in which they were fed into the engine at the reverse end.

The fibres of wool are to be removed from the points of the cards of this cylinder by a fluted roller turning in contact with it, by which means the slivers again assume the form of bands of slubbing, and are then passed between a pair of rollers to compress them. They are then conducted between two straps, or a doubled endless band, travelling in opposite directions, in order to give a slight degree of twist to the fibres of the wool; and after this the slubbings are passed between another pair of rollers, turning somewhat faster than the former pair, for the purpose of drawing out the fibres and slightly elongating the bands of slubbing.

The slubbings are next wound or lapped upon a roller or long bobbin, which is made to turn upon its axis by the friction of its contact with the surfaces of two revolving rollers below, driven by the gearing-wheels of the engine; and this lapping-roller has a short lateral movement to and fro in its carriage, for

the purpose of causing the several bands of slubbing to be wound in a slight degree spirally, or in helical curves round the bobbin.

The claims of the patentee are, first, to the mode of feeding the slivers into the carding-engine immediately from a series of cans, and of passing it in distinct bands over guide-rollers into the engine: second, to the adaptation of a cylinder with bands of cards for stripping or taking off the slivers from the doffer-cylinder; and third, to the employment of a second pair of rollers for the purpose of drawing or slightly elongating the slubbings.

The woollen-yarn spinners claim for their branch of the manufacture which follows the slubbing the character of a completely healthy occupation, and not without justice; for although the dirty and greasy appearance of the operatives at the jennies and mules, and the strong effluvia of animal oil perceptible in some mills, convey at first a different impression to a stranger, neither the men, nor the few children who are required, are found to suffer from the nature of the occupation, and many are said to receive benefit from it.

The wool slubbings or rovings are spun into yarn of the requisite fineness either by the jenny or the mule. The latter being, properly speaking, a machine belonging to the cotton manufacture, must be reserved for that department of our work. The following description will render the nature of the process tolerably clear.

Fig. 32 represents a mechanism intermediate between the jenny and the mule. It has only one pair of rollers A; the under one is fluted iron, and the upper one

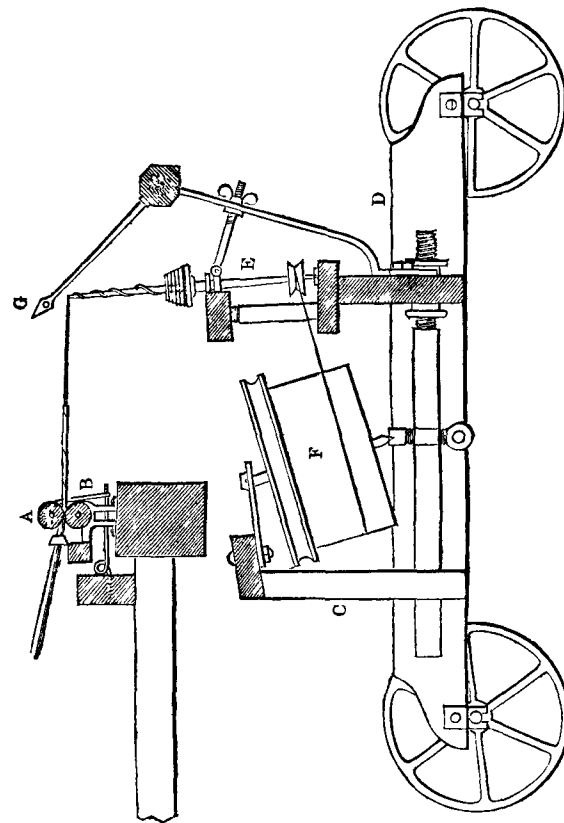

Fig. 32.—Wool-Spinning Mule.

wood, with an iron axis, which is made to press downwards by springs acting at B. These rollers, by means of a peculiar mechanism driven by the main axis of the machine, deliver at each movement of the carriage, the length of roving requisite for one stretch, as has been explained in describing the slubbing frame. The carriage C is constructed exactly as in the mule jenny; the spindles, which travel with it, receive

their motion from the vertical drums F. The spinner is saved from the care and exertion of bringing out the carriage, that operation being performed by the moving power on automatic principles, as in the cotton-mule; but he executes the winding of the yarn on the spindles, by pushing the carriage back to the roller beam, and depressing the faller-wire G at a proper inclination for forming a regular cop. For every kind of cloth two qualities of yarn are required; the first hard twisted and strong, to form the warp or the chain, and the second of a softer and more elastic texture, to form the woof or weft; and these are always carefully distinguished.

In the woollen manufacture, as the cloth suffers, by the operation of the fulling-mill, a shrinkage of its breadth to well nigh one-half, it must at first be woven of nearly double its intended width when finished. Superfine six-quarter broad-cloths must therefore be turned out of the loom twelve-quarters wide. For making such broad webs by one weaver, the fly-shuttle of John Kay was a precious invention; prior to which two men were employed to throw the shuttle from one to the other. The minutiae of warping and weaving apparatus will be fully explained in treating of the cotton trade. Hitherto power-looms have been sparingly introduced into the manufacture of cloth; but some have been recently constructed by Messrs. Sharp and Roberts, which work extremely well, and with very little friction. I saw one of them weaving a twelve-quarter cloth with the same precision and facility as their common power-looms weave calicoes and fustians.

At each side of the woollen warps, a few threads of



strong coarse yarn are placed, to form the lists or selvages of the cloth, which strengthen it, and serve to receive the hooks for stretching it by in the tenter-frames after milling. The piece of cloth must be cleansed from the oil with which the wool was embued in the carding operation, before it can be fullled. The scouring process is performed by a pair of stocks, driven by machinery, in a mill similar to the fulling-mill. The stocks are two large wooden mallets, suspended with the handles or helves in an inclined position, and lifted in succession by cogs fixed on the axis of a water-wheel. When the cogs escape from the raised mallets, they allow the heavy heads to fall by their own weight, like the bobs of a pendulum swinging to their centres, and to strike the piece of cloth contained in a wooden trough, by an action extremely like kicking with the toes. The slant ends of the hammers not only beat and compress the piece of cloth, but turn it continually round, by sliding under it upon the sloping bottom of the trough. The back of the trough being curved, permits the cloth to turn upwards before each successive kick, and to move somewhat round in tumbling down again on the alternate recession of the stock. As a large bulk of cloth is scoured at a time, only the bottom of the heap receives the blow, but being heaved about by the wedge-like beak of the mallet acting against the slanting base and back of the trough, that bottom part is continually changed, so as to bring the whole mass in a short time under the operation. The cloth takes, in fact, a circulating movement, and thus exposes itself spontaneously, so to speak, to a most effectual rubbing, tossing, and beating process. When the cloth is sufficiently scoured, first by water with a

little soap or other detergent matter, and then by pure water alone, it is taken out of the trough, and extended with its edge upright, on a vertical frame, called the *tenter*, where it is left to dry in a stretched state.

*Burling* is the name of a process, in which the dried cloth is examined minutely in every part, freed from knots or uneven threads, and repaired by sewing any little rents, or inserting sound yarns in the place of defective ones. The fulling operation which follows entangles the fibres of the repaired spots in such a manner, as to conceal the defects, and give the whole a uniform appearance.

In the fulling-mill, both the stocks and trough are differently shaped from those just described, though the mallets are suspended and driven in the same way. The milling-trough is so formed, that the cloth cannot escape by sliding up from the blows of the hammer, because the face of it opposed to the beak of the mallet is nearly flat, and at right angles to the direction of the blow, whereby the cloth is exposed to percussive pressure between the mallet and the back of the box. The hammers are made to strike very heavy blows, but without wearing the woollen texture, because they always impinge flatly against many folds of cloth. The helves of the fulling-mallets are placed in a position different from those of the scouring-stocks, in order to make them fall more directly at every stroke. Hence they are called falling-stocks, while the scourers are called hanging-stocks, because the handles being nearer the perpendicular, cause the mallets to move more horizontally, and impinge more lightly on the cloth. The stocks should make from thirty to forty blows per minute, in a well-constructed fulling-mill.

According to Smeaton, the power of four horses is required to work one pair of stocks for fulling bays; and it would take probably more power to full broad-cloths.

In fulling or milling a piece of cloth sixty-two yards long, six pounds of soap are dissolved in a little water, and a handful of the solution is spread upon every yard. The piece is now put into the trough, and worked for three hours, being frequently turned to expose fresh surfaces to the blows of the stocks. The fibres of the wool are thus compacted together, sliding more easily among each other in consequence of the lubrication of the soap, till the whole become matted into one mass. After three hours' milling, the cloth is taken out of the trough, soaped as before, and then subjected to the stocks for three hours more. This process is repeated four times in the course of twelve hours, and is succeeded by a rinsing operation, a stream of clear water being admitted into the trough to wash out the soap. The piece of cloth is now found to be reduced to a breadth of about sixty inches from one hundred, and a length of forty yards from sixty-three.

The asperities on the surfaces of woollen fibres, and their great elasticity, render them difficult to card, spin, and weave; and require them in manufacture to be lubricated with oil to the amount of nearly one-fourth part of their weight. In the process of scouring by the stocks, this oil is washed out with the aid of crude alkaline matter, fullers'-earth, and occasionally a little soap. After milling, the stuff partakes at once of the nature of a woven tissue and of a felt. On this account the cut edges of broad cloth are not apt to unravel their yarns, and need not be hemmed like those of cotton, linen, and silk goods.

An ingenious improvement on the old fulling-mill was patented in 1826, by Messrs. Willan and Ogle, cloth manufacturers, Leeds, in which the standard and bed of the stocks are made of iron instead of wood, and a steam case is placed under the bed to heat the cloth during the operation.

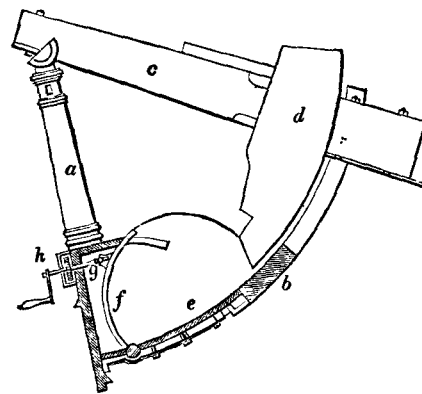

Fig. 33.—Willan and Ogle's Fulling Mill.

Figure 33 is a section of the machine: *a* is a cast-iron hollow pillar, *b* the bed of the stocks of iron polished smooth, *c* the lever or handle of the mallet or beater *d*. The cloth is laid on the bed *b* at the bottom, and subjected at once to a stream of water, and to the blows of the beater. The bed at *e* is hollow and forms a steam-chest, connected by a pipe with a boiler, the heat from which is said greatly to facilitate and improve the cleansing and fulling processes. The smoothness of the metal of the stock-bed prevents the nap from being worn off the cloth during its frequent turning over by the wedge of the beater, and thus preserves its beauty. The tendency of the cloth to

turn over in the mill depends in a great measure upon the form of the breast of the stock against which it is driven by the mallet. In the present machine there is a contrivance by which that form may be modified in order to suit different fabrics of cloth. The curved breastplate *f* is movable round a cylindrical hinge-rod seen in section, which runs across the bottom of the trough. This breastplate is acted upon by a screw-rod *g* attached to its back, and may by this means be pushed forwards or backwards to any desired inclination. The spur-wheel *h* works both to its right and left into the teeth of a similar spur-wheel, each of which wheels has for an axis a screw-rod similar to *g*, so that all the three moving together push forward or draw back simultaneously the three rods, and furnish firm stays to the breastplate. At the upper part of the plate there are guide-pins which pass through concentric curved slots.

The foundation of men's hats, upon the outside of which the beaver down or other fine fur is laid, to produce a nap, is usually made of wool felted together by hand, and formed first into conical caps, which are afterwards stretched and moulded upon blocks to the desired shape. There have, however, been various kinds of machinery employed of late years for setting up hat bodies, by coiling loose filaments of wool into the form of conical caps, and causing them to cross each other in the winding on, for the purpose of taking hold of each other, so as to produce a matted or laid texture, when exposed to heat with friction, or the felting process. An ingenious contrivance of this nature was made the subject of a patent by Mr. Borrodaile in 1825, which, with improvements, was pa-

tented again by Mr. Williams, in 1826. It consists, first, of an apparatus to be attached to a carding-engine, by means of which the slivers or porous ribands of wool are taken off the doffing-cylinder of the carding-engine, and wound in different directions, for the purpose of becoming matted together, upon blocks of various figures, suited to the size of the intended hat or cap; and secondly, in an apparatus having heated plates and rollers, upon which the matted caps are pressed and rolled, to harden them previous to felting.

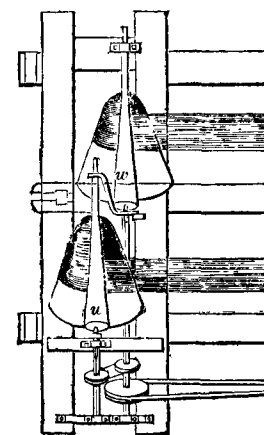

Fig. 34.—Williams's Hat Felter.

The wood-cut (fig. 34) shows in plan the sliver as delivered from the carding-cylinder, winding on cones which turn upon horizontal axes, and also traversing a little to-and-fro, in order to distribute the fleecy riband crosswise along their sides, and likewise over their hemispherical ends. These cones are made to vary in their rotatory speed according to the diameter of that part of the block which is receiving the sliver, other-

wise the slivers would not be wound on with uniform tension. This variation of velocity is produced by connecting these blocks, by straps, with a pair of driving-cones reversely mounted, and of a corresponding shape, the straps being made to traverse backwards and forwards on the surfaces of the cones. Two heavy conical rollers are seen at *w w* bearing on the peripheries of the blocks, but turning loosely upon their axles by the friction of contact, for the purpose of compressing the slivers of wool on the blocks. When they have been coated with a sufficient quantity of the woolly fleece, the smaller end of the pressing-roller is to be raised, to allow the cap to be removed from the block. Another set of bodies is then begun. The caps, thus formed, are folded in wet cloths, and placed on steam-hot plates, where they are rolled by a machine, or the hand, under pressure, for the purpose of being condensed. They are now to be felted, either in the usual way by hand, or in a fulling-mill, from which they are taken out occasionally, and passed between rollers, to render the felt more perfect.

*Tentering.* When the fulling is finished, the cloth is stretched once more on the tenter-frame, and left in the open air till it is dry.

*Teasling.* The object of this operation is to raise up the loose fibres of the woollen yarn into a nap upon the surface of the cloth, by scratching it either with thistle-heads called teasels, or with teasling cards or brushes made of wires. The natural teasels are the balls which contain the seed of the plant called *dipsacus fullorum*; the scales which form the balls project on all sides, and end in sharp elastic points, that turn downwards like hooks. On the hand-work plan,

a number of teasels were put into a small frame, having crossed handles, eight or ten inches long. Being filled with the thistle heads, it formed a tool not unlike a horse curry-comb. It was used by two men, who seizing the teasel-frame by the handles, scrubbed the face of the cloth hung in a vertical position from two horizontal rails fixed to the ceiling of the workshop. The first time of dressing the cloth they wetted it with water, and worked it, first three times over by strokes in the direction of the warp, and next in that of the weft, so as to raise up all the loose fibres from the felt, and prepare it for shearing. In large manufactories this dressing operation is performed by what is called a gig-mill, which originally consisted of a cylinder bristled over with the thistle heads, and turned rapidly round while the cloth was drawn over it in variable directions. When the hooks of the teasels got filled with flocks of wool, they were taken out of the cylinder and cleaned by children with a small comb. The quantity of teasels required being very considerable, caused them to be much cultivated in the cloth districts; notwithstanding which they became excessively dear in some seasons, from occasional failure of the crops. Moisture also softens their points and impairs their teasling powers; an effect which needs to be counteracted by taking them out and drying them from time to time. Many contrivances have therefore been made for substituting metallic teasels of a permanent nature, mounted in self-acting machines, for the thistle balls. The following figure and description will convey an idea of their structure and use. It ought to be observed, however, that for the fine fabrics a shearing process in the dry state must alternate with

a teasing one in the wet; on which account the cloth must be drained and stove-dried between the two operations.

In Mr. Atkinson's improved machine (see figures 35, 36,) for raising woollen-cloths, commonly called a gig-mill, the teasel boards or frames are attached to the gig-barrel by a peculiar fastening, which enables the patentee to introduce springs between the frames and the barrel, and thereby to allow a degree of elasticity to their operation, when acting upon the surface of the cloth, in raising the pile or brushing the nap.

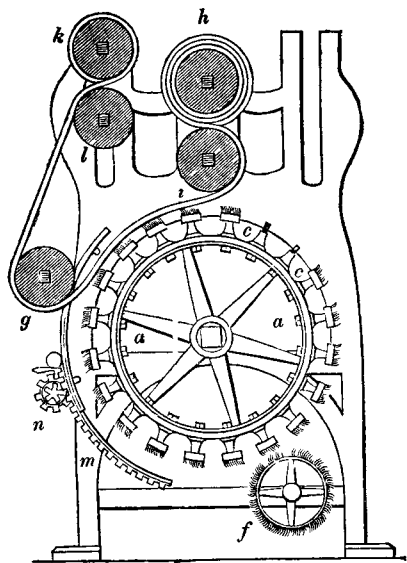

Fig. 35.—Atkinson's and Walker's Gig Mills united.

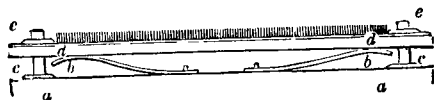

Fig. 36.—Teasel.

Fig. 35 exhibits a section taken transversely of a gig-mill, in which several of the teasel cards are removed for the purpose of showing the place of the springs that are to act beneath them. Fig. 36 represents one of the boards attached to the barrel upon an enlarged scale. The ordinary gig-barrel is figured at *a, a*, fig. 35. In fig. 36, *b, b*, are thin pieces of steel fixed by screws to the surface of the barrel, and bent upwards to constitute springs that shall support the teasel-boards when mounted on the barrel; *c, c*, are iron-pins set radially into the barrel near each end, and fastened by screw-nuts below; *d* is the teasel-board readily mounted by passing the pins *c, c*, through the holes near the ends of the boards, such holes being lined with smooth brass bushes, and the boards being secured to the pins by the screw-nuts *e, e*. The pins are made somewhat smaller than the holes, so that the board may slide easily up and down upon them; but as it is pressed upwards by the springs *b, b*, it is kept in close contact with the nuts, unless forced down by some incumbent impulse. It is obvious that by this elastic contrivance, the pressure caused by the tension of the cloth, as the gig-barrel revolves, is relieved, and any injury likely thereby to result to the cloth is prevented. The pile is also said to be more perfectly raised and with a softer nap. The brush at *f*, fig. 35, keeps the teeth of the teasels clean.

I have, for the sake of completing the illustration in the best manner, introduced into the same figure, certain additions recently made to the common gig-mills, by Mr. S. Walker of Millshaw, near Leeds, for which he has also obtained a patent. Mr. Walker's improvements consist in the novel arrangements of the rollers

and the parts connected with them, which conduct the cloth over the teasel-cylinder, and keep it smoothly distended during the process of raising the pile: *h* is the roller upon which the cloth is originally wound; *i* is a guide roller driven by wheel-work on the end of its axle, on the surface of which the cloth from *b* is always made to bear, and is therefore drawn onward by friction; *k* is a third roller, round which the cloth is lapped in proportion as it is given off from the first roller *h*; *l* is similar to *k*, and is driven by wheel-work on its axle, and hence by friction turns *k* which bears upon it. The tension or stretching-roller *g*, has its axle mounted in the segment-racks *m*, as usual, and it is raised or depressed by turning the shaft of the pinion *n*.

In order to put the gig in action, rotatory motion is given to the teasel cylinder in one direction by wheel-work on its end, whereby the roller *k* is made to revolve and to draw the cloth from the roller *h*, over and under the roller *i*, thence over the surface of the gig-cylinder towards the tension roller *g*, under and round it, and over *l*, till all the cloth has been coiled round *k*. In order to take the cloth back again through the machine for the purpose of being further operated upon by the teasels, the clutch of one of the driving wheels is unlocked, so as to loosen it, while the clutch of another is pushed in, whereby the roller *h* becomes active in winding on the cloth, and the roller *k* passive in giving it off. This alternate circulation of the web from the roller *h*, to the roller *k*, and back again, may be continued until the pile of the cloth has been sufficiently raised. The first of these patents was enrolled in August, and the second in

September, 1832. The two conjoined appear to constitute an excellent self-acting apparatus.

*Shearing, or Cropping, is the next operation.* This shaves the surface into a level nap, and was originally done by hand-shears, applied to the cloth stretched across a stuffed table, but it is now perfectly executed by automatic apparatus. The first introduction of shearing-machines in 1802, was viewed with such jealousy by the operatives, as to occasion very serious riots in some districts, especially in Wiltshire and Somersetshire, and to attract the attention of parliament. The committee of its members appointed to investigate the matter, reported, that decisive evidence had been adduced before them by merchants and manufacturers of the greatest credit and experience, to prove that these machines, when carefully employed, finish the cloth in the most perfect manner, and that manufacturers residing in parts of the country where the gig-mill is not used, frequently sent their cloths to a distance to be dressed by it; that similar alarms had been created among workmen at the introduction of other machines, now admitted to be most beneficial to the trade and to everybody engaged in it; for besides the occupations created by attendance on such machines, a greatly increased demand for labour had resulted from the extended sale of goods, in consequence of their greater cheapness and superior quality.

The wood-cut, (figure 37) represents in a plan or ground view, a machine for shearing cloth, for which a patent was obtained by Mr. George Oldland, of Hillsley, in Gloucestershire, in March, 1832. He employs disc-formed cutters *b, b, b*, working against a thin bar of steel called a *ledger blade, a, a, a*, of a semi-

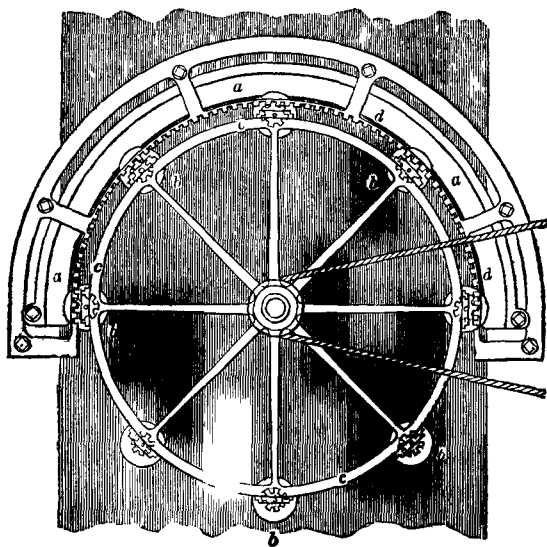

Fig 37.—Oldland's Cloth Shearing Machine.

circular form, which cutters traverse or travel round against the edge of the blade, in such a way as to produce a shaving operation on the projecting filaments or pile that had been raised by the teasing machine on the face of the cloth.

The cutters *b, b, b*, are mounted upon perpendicular spindles in their centres, attached by loops to the circumference of the large working wheel *c c*; and each cutter spindle carries near its bottom a toothed pinion, which on the wheel *c* going round, takes into the semi-circular rack *d, d, d*, and thereby gives each *disc-cutter* a quick rotatory motion on its centre as it moves along the semi-circle, like that of the earth on its axis while it revolves round the sun. The great wheel *c*, the ledger blade *a*, and the rack *d*, are supported by suit-

able means in the upper part of the framing of the machine; and the wheel itself is driven round by a band and pulley, as is shown in the figure.

The disc-cutters are here placed so as to act against the concave edge of the ledger-blade; but they may for certain purposes be constructed to act against its convex edge, by a little variation in the relative dimensions of the parts. The cloth must be laid on a bed made to suit the form of the ledger-blade, and must be kept stretched to its proper tension by means of a counter-bed or guard on the upper surface of the cloth, not visible in this view. This shearing-machine may be brought into action upon the surface of the cloth, either by carrying the cutter and ledger-blade machinery over it along the length of the piece, or the cloth may be conducted progressively under the cutter and ledger-blade kept stationary; either action being equally easy in a forward or backward direction.

In the specification of his patent, Mr. Oldland describes also a plan of introducing currents of air to act upon cloth in its passage through an ordinary gig-mill, dressing or brushing-machine, in order to promote the evaporation of the water contained in the cloth, and to cause the nap to be laid by such mode of drying.

The cloth is now ready for the brush-machine, in order to smooth down the woolly nap, after which it receives the finish or lustre. This last process has been long practised by superior machines in England. Hence English broad-cloths became distinguished not only for their soundness, but also by their beautiful aspect; advantages due to the perfection of our spinning-machines, to the moderate degree of twist of the warp yarns, to the wider space between the dents of the

reed in the loom, and to the general regularity of the weaving. When they are taken from the loom, they are immersed in water to remove the dressing paste of the warp, are rinsed, and then instead of being hung up to dry, they are subjected to a brushing-machine, with brushes made of boar and swine's bristles mixed with wires. By the application of steam to the wet cloth in this process, the dressing is thoroughly cleared away, and the fibres of the warp are laid smooth and flat. The cloth thus gets more readily condensed in the fulling-mill, and the shearing may be also more conveniently executed. It is again passed through the brushing-machine, a practice which is repeated according to the judgment of the operator; and lastly, it is submitted to dry brushing.

Machines have been made which will conduct in a few minutes one piece of cloth over two revolving brushes, and through a calender press. In its passage the cloth is exposed to steam, discharged in numerous jets from a flat copper box pierced with little holes. When the dye is very fast, the cloth may be passed repeatedly through the machines, even to the twentieth time, without being affected; but when its dye is delicate, it must be less frequently exposed to this process. At the beginning of the process, the body of the cloth is laid in a box below, while its end is introduced between rollers, to give the web the requisite degree of tension. The current of steam is supplied from the copper box, which extends across the breadth of the machine. The cloth is then led between the cylinder brushes, on which it is pressed by a roller. It proceeds to pass between two calender rollers, and thence it falls upon an inclined board, in its way to the box. As the ends

of the piece are usually stitched together, the cloth continues the same revolution till its finish is completed.

The perforated copper-box extending across the whole breadth of the machine, receives steam by a pipe connected with the boiler, and discharges the condensed water into a cistern placed beneath.

The roller for holding the cloth against the brushes may be made to press with more or less force, by being raised or lowered in a slit of a prop, and by clamping it at any height by a screw near its base.

The polishing rollers or calender serve to smooth the woolly surface; they are made of wood covered with canvass or linen. They rest on iron bearings, and are made fast at their two ends by plates of iron furnished with clamping screws. They revolve by the friction communicated by the passage of the cloth.

In treating cloth by this apparatus, steam ought to be freely used. Experience proves that from fifteen to twenty cubic feet of steam of atmospheric density are required per minute; and when a single pipe is deemed insufficient to supply this quantity, two or more pipes perforated with holes are laid horizontally across the machine as substitutes for the copper-box.

*Pressing* is the last finish of cloth to give it a smooth level surface. The piece is folded backwards and forwards in yard lengths, so as to form a thick package on the board of a screw or hydraulic press. Between every fold sheets of glazed paper are placed to prevent the contiguous surfaces of cloth from coming into contact; and at the end of every twenty yards, three hot iron plates are inserted between the folds, the plates being laid side by side, so as to occupy the



whole surface of the folds. Thin sheets of iron not heated are also inserted above and below the hot plates to moderate the heat. When the packs of cloth are properly folded and piled in sufficient number in the press, they are subjected to a severe compression, and left under its influence till the plates get cold. The cloth is now taken out and folded again, so that the creases of the former folds may come opposite to the flat faces of the paper, and be removed by a second pressure. In finishing superfine cloths, however, a very slight pressure is given with iron-plates but moderately warmed. The satiny lustre and smoothness given by strong compression with much heat is objectionable, as it renders the surface apt to become spotted and disfigured by rain.

No female children are employed in the finishing of cloth, and very few boys. The business to which children are first put in this business is carping; that is, preparing thistle-teasels for the workman, who fits them into the rods and handles for dressing the cloth. The little carpers sit at this easy work, and are generally hired and paid by the operative dresser.

The next employment in the cloth manufacture for which boys are fit, is *preeming*; that is, cleaning the teasel-rods and handles, to which is sometimes added the task of carrying the rods to and from the drying-house. In large establishments, however, this task is usually discharged by men. Preeming is much harder and more disagreeable work than carping; for it requires the carrying of the rods into the dry-house, and consequent exposure to sudden and violent changes of temperature, the heat in the dry-house being sometimes raised so high as 110° or 120° Fahr., in order

to dry the tentered cloth within it. After the preeming period, the lads are put either to the gig-machines, or to the lewises in the cutting or shearing-room. The older gigs were large cylinders set round with rods, in which the teasels were fixed for raising the pile on the cloth. The business of those who mind the gigs is to watch and fold the cloth as it runs round the rollers in front of them; while a constant jet of water is made to play upon the cloth during the process, which keeps the workshops in a wet and disagreeable state. The labour of removing pieces forty yards long must also be considerable.

In the cutting-rooms the old machines for shearing the cloth are principally of two kinds—shears and lewises. The management of the former is beyond the strength of boys, as the cutting edge is kept close to the cloth by heavy weights, which must be shifted by the workman at each successive portion of the surface operated upon. The lewis is a cutting instrument of a more complicated mechanism, and is generally managed by a man and a boy; the latter being employed principally to fold the cloth that has been cut, and assist the workman in fixing another length on the frame of the machine, across which the box, containing within it the cutting-edge, is made to travel. The hardest work in the cloth-finishing business seems to be that of the *hand-raisers*, who bring out a nap on the cloth spread before them on an inclined plane, by scrubbing it with teasels fixed in hand-frames.

In the course of finishing, the cloth passes several times to and from the raising and cutting-rooms. The only branches of it which exercise female industry are the brushing and burling. The *burlers* have the cloth

spread out before them, and pick out any roughnesses or extraneous substances that have been left by the weaver, or introduced into the cloth during any of the subsequent processes. Generally, young women, from seventeen to eighteen and upwards, are engaged in this department. Machines for burling, called *épincéteuses*, have been, many years ago, introduced by the French into their fine-cloth manufactories. Their complexity and limited use preclude their being described in the present work. An elaborate account of one of them is given in the *Bulletin de la Société d'Encouragement*.

Between the loom and the gig-machine the cloth is scoured and fulled, as already explained.

The following is the nomenclature of the operatives engaged in our woollen manufacture :—Wool-sorters, pickers, willyers (winnowers), carders, scribblers, pieceners, slubbers, spinners, warpers, sizers, weavers, scourers, dyers, burlers, fullers or millers, boilers, giggers, dryers, croppers, singers, glossers, pressers, brushers, and steamers. The last set superintend the finishing of cloths, in presses, under the influence of strong steam. The hand-raisers earn 22s. per week; and though they have harder work than the raisers at the gigs, they receive less wages than the latter, who receive extra pay to secure punctuality of attendance on the machine.

Notwithstanding the pecuniary aid which the Minister Colbert granted to M. Cadot to establish a manufacture of broad-cloth at Sedan, under the direction of Dutch artisans, the proprietor was on the eve of bankruptcy, in consequence of his great expenditure in training a body of workmen, and of the sacrifices

he was forced to make, in competing with a similar manufacture at Leyden. The public treasury being exhausted by war, Colbert could advance no money to relieve his friend in distress, but he persuaded Lewis XIV. to wear a green-striped coat of the light Pagnan fabric, and to declare in presence of his court, before setting out for the chase, that he considered that kind of dress very beautiful. Immediately the courtiers about his person, and all their dependent courtlings in the country, became so solicitous to get similar coats, that they bought up an immense quantity of cloth (which the Minister knew to be lying by in store), at such an exorbitant price, as not only to put in activity the works of Sedan, but to cause the erection of a similar manufactory at Rheims, where an analogous stuff was for a long time made, under the name of *Silesian*.

The French are still of opinion that their broad-cloth fabrics of Sedan and Louviers surpass those of all Europe in beauty and perfection. At the former place, piece-goods, especially blacks, are admirably dyed; and at the latter, the wool is dyed in a superior style, especially for blues.

It is a principle universally admitted that the finer, the shorter, and even tenderer the staple of wool, the better fitted it is to produce a fine, soft, glossy, and silky-looking cloth, of good wear. The reason is, that the shorter the filaments are, and the more points they present in a given volume or weight, the better adapted they are to interlace with each other,—a property indispensable to the fulling process. In fact, the slenderer they are, the more compact may they become, or more of them may be condensed in a given space, and the finer and firmer yarns may they be

spun into. From the union of fineness and shortness in the staple, the operation of teasing, which is performed after fulling, causes a great number of little filaments to be pressed together into a small surface, and to form a fabric soft and elastic to the touch, brilliant to the eye, and not apt to become threadbare by use.

Blankets could not be made with British wool alone, so as to sell in the export market; they would be too costly. They must contain two-thirds of the low-priced wools of Russia, Germany, Italy, and the Levant.

Prior to 1824, some English manufacturers of good broad-cloths from 7s. to 25s. per yard, for the home trade, worked entirely with British wools from Sussex, Norfolk, Suffolk, and Hampshire; but since that time they have used nothing but foreign wool, from Germany chiefly, and some from Spain. English wool, in consequence of the deterioration of its quality, became unfit for the finer descriptions of goods. "We kept to English wool," says Mr. John Brooke of Horley, Huddersfield, "longer than any house in our neighbourhood, on account of our large connexion for its purchase; but we found that our neighbours were sending out better cloths than we were. Up to 1813 English wool alone was found to answer; from that time to 1824 a mixture of foreign was required; and since 1824, foreign alone has become necessary. Last year (1827) we got home from fifty to sixty packs of the best wool to be found in Sussex, and it was so coarse that we could use it only in the edging of cloths or listing. The description of English wool we used at that time (1814) is not produced at present."

## CHAPTER V.

### *Nature and Operations of a Flax Factory.*

FLAX is the bark or fibrous covering of the stem of the well-known plant called by the botanists *linum*, because it constitutes the material of linen cloth. The spinning filaments are separated from the parenchymatous matter either by steeping the plant in water, or by exposing it for some time to the action of the air and weather. The former, which is the commonest or safest method, is called *water-retting*, the latter is called *dew-retting*. Both act by exerting a slight degree of fermentation in the substance which attaches the flaxy filaments to the vegetable vessels and membranes. The crude flax is dried by being spread on the grass, and is then subjected to the action of an instrument called the *brake*, which breaks and separates the boon or core from the true textile flax.

*The hackle or heckle* is an essential implement used in the manufacture of flax for dividing, cleaning, and straightening its fibres. It is a strong comb comprised of several rows of iron or steel pins, several inches long, fixed upright in a square block of wood as a base, across the pointed summits of which the strick or lock of flax is thrown, and drawn through the teeth either by hand or mechanical power. As considerable force as well as art are requisite to heckle

well, without injuring the flax, the block must be made fast to a bench, in front of the workman, when the operation is a manual one. Coarser and wider-toothed heckles are used first, and then others progressively closer-toothed, as the fibres become finer, by separation.

Many automatic heckles have been invented of late years. That for which Mr. Joshua Wordsworth, machine-maker of Leeds, specified a patent in June, 1834, is one of the most recent and ingenious. Figures 38 and 39 represent this machine in a horizontal plan, and in an end view. A A, are two large barrels or drums, bearing on their surfaces longitudinal brass ribs *a, b, c, d, e, f, g, h, i*, bristled with heckle points. The barrels have these ribs fixed at small distances apart

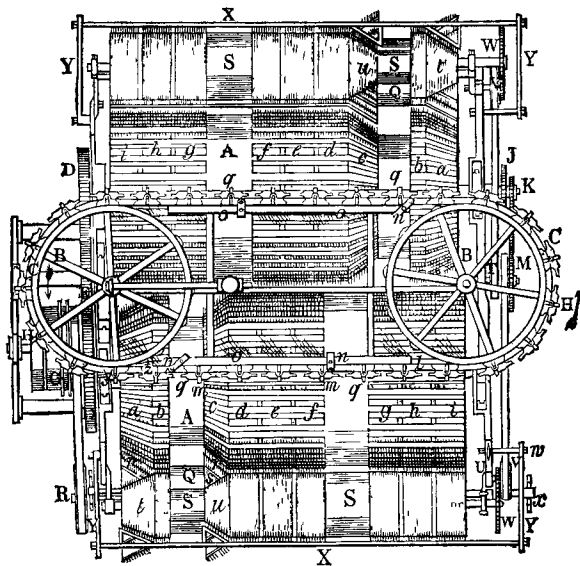

Fig. 38.—Plan of Wordsworth's Flax-heckling Machine.

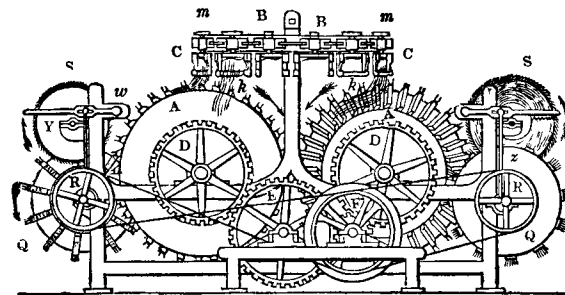

Fig. 39.—Section of Wordsworth's Flax-heckling Machine.

round their surfaces, and present their heckle points radially from their axes, being themselves mounted upon axles supported by pedestals at their ends. B B are two horizontal wheels or pulleys, turning upon vertical shafts, which pulleys conduct an endless chain, C, C, C, C, carrying the holders or mechanical hands, which suspend and apply to the points, the stricks of flax to be heckled. At one end of the axle of each barrel a toothed wheel, D D, is fixed, connected with other wheels through which the whole machine is driven, and the heckle-barrels, A A, are made to revolve in opposite directions to each other, as shown by the arrow in fig. 38.

The stricks of flax intended to be operated upon are severally confined between pairs of clamps *k*, fig. 39, fastened together, which clamps or hands, with the stricks, are then suspended in their respective holders H H, attached to the endless chain C; the lower portions of the flax hanging down for the purpose of being acted upon by the rotatory heckles on the barrels, while the upper portions are turned up in loops, and confined by spring levers attached to each carrier.

The several holders of the clamps consist of a forked frame, with hooks at the lower parts of their arms, which receive the ends of the clamps *k*, that grasp the strick of flax. From the upper part of each forked frame a perpendicular pin extends, which pin, when inserted into the sockets *l, l, l*, in front of the chain, form axles for the frames to turn upon at certain periods of the operation.

On the upper end of each pin a small arm *m* is fixed, standing at right angles to the face of the forked frame of the holder *H*. As the endless-chain carries onwards the holders, these arms come in contact at certain points with stationary pins or wipers *n n*, fixed to the guide-rails *o*, on which the chain *C* slides; and these wipers acting against the arms as they pass, cause the holders to be turned round at those periods, for the purpose of bringing the reverse side of the strick of flax on to the heckle-points.

Let it now be supposed that all the hands or holders connected to the endless-chain have been furnished with stricks of flax, and that the barrels *A A* are set a-going; they will communicate rotatory motion to the pulley *B*, will make it drive the chain *C* forwards, and thus conduct the several stricks of flax progressively along the barrel.

When each successive handful of flax is brought to the part *z*, fig. 38 the lock comes into contact with the revolving-barrel, striking first upon the series of coarse heckles *a a*, which project from the inclined surface of the conical end of the barrel, so as to let only the lower ends of each strick be combed out. As the holder advances along its chain-way it comes over a more prominent part of the barrel, and lets the

strick fall nearer its middle on the heckle-teeth, till it ultimately brings the whole length of the suspended strick upon the heckle. By this progressive heckling, from the dangling tips to the roots of the strick at the holder, so to speak, the long fibres are not torn asunder, and therefore a smaller quantity of tow is produced than by the ordinary modes of heckling.

After the strick has been carried by the travelling chain past the first inclined plane at the conical end *a*, fig. 38, it comes next upon the cylindrical portion *b* of the barrel, also furnished with coarse heckle-points, which penetrate and comb down the whole pendant lock of the flax. But in order that both sides of the strick may be equally combed, the holder is made to turn on its pivot by an arm of the lever *m* coming against the stationary pin or wiper *n*, as shown at *p* in the ground-plan.

The under part of the guide-rail *o*, upon which the chain slides, is at this part cut away, for the purpose of allowing the holder to turn round in a horizontal plane; while a projecting pin, at the under side of the guide-rail, acts against the side of the carrier-frame as the chain goes on, forcing it into a position parallel with the chain. The other side of the strick of flax is by these means brought on to the heckles of the second barrel, first at its inclined surface or conical end *c*; and as the chain advances with the holders, the pendent stricks are successively made to pass over and be combed by heckles of increasing fineness *d, e, f*, on the cylindrical portion of the revolving barrel, until having arrived at the second wiper *n*, the holder *g* is turned round as before, and brings the reverse side

of the strick, or that part operated upon by the heckles *a* and *b*, progressively on to the heckles of increasing fineness *g*, *h* and *i*. When they have passed the last series of the heckle-barrels, the holders have completed their work, and are to be successively removed from the machine.

The clamps of the holder being now opened by the attendant, the stricks of flax are removed, and these replaced between the clamps in an inverted position, the combed ends being turned up, and the uncombed being made to hang down upon the heckle-barrel.

It should be remarked that, as different kinds of flax may require different degrees of heckling, this adaptation may be made by varying the comparative speeds of the travelling-holders and the heckle-barrels, by changing the wheels and pinions on the ends of the said barrels.

In the above process the tow taken off from the stricks by the heckle-points would adhere to the barrel between the ribs, and clog the heckles, were it not constantly removed by several brushes, or blocks with bristles, fixed longitudinally to the revolving-cylinders *Q Q*, fig. 39. These brush-barrels are shaped to suit the contour of the heckle-barrels, and are caused to revolve in opposite directions to them, with sufficient speed to enable the brushes to pass through between the points of the heckles, and thereby to remove the tow or loose vegetable matter. The tow so collected is transferred from the brushes to wire-cards, covering the surfaces of the cylinders *S S*, which also are made to revolve on horizontal axes, fig. 39, but very slowly. The tow is finally taken off these card-cylin-

ders by a doffing-knife *X*, as in common carding-engines supported by levers *Y Y*, vibrating upon fulcrum pivots at *w*, fig. 39.

This machine is replete with automatic contrivances, which co-operate in a very simple manner towards the accomplishment of a delicate operation; and when properly made and tended, it promises to do excellent work in a flax-mill.

A system of machines for scutching and heckling flax was specified by patent for Mr. T. M. Evans, as the invention of a foreigner, in July, 1833, which also contains many ingenious devices. It is intended to do its work within wooden cases, to prevent the annoyance from dust so plentifully thrown out in every stage of flax-dressing. Not having seen this machine in action, I cannot venture to give an opinion of its efficacy when so encased. Some method might be adopted of encasing the main parts of Mr. Wordsworth's apparatus, so as to carry off by fans the greater part of the flying particles.

In ordinary mills, the flax, as imported, is delivered to the hand-hecklers, who roughly separate the fibres by drawing the bunches through the spikes of the bench-heckle as already described. This is a dusty process so far as it goes, but much less than when it was the only mode of heckling, and is at any rate never performed by children. From the hand-openers the flax is carried to the heckling-machines. Young boys, called *machine-minders*, with occasionally a few girls, tend them, fixing the stricks in the holders, and moving them at the proper time from the coarser to the finer heckle, taking them out and inverting them, as in Mr. Wordsworth's self-acting heckle, and replacing

them when finished by fresh stricks. The locks of flax are screwed into the holders by a boy called the *screwer*, generally younger than his companion the *machine-minder*; and his labour appeared, to a most intelligent factory commissioner\*, to be, beyond comparison, the most fatiguing that he had seen children subjected to, independently of the noxious atmosphere, loaded as it is with particles of flax incessantly detached and scattered by the whirling of the machines. The *screwer* seems not to have, with the common heckling-machine, an instant's cessation from labour; bunch after bunch is thrown down before him to fix and unfix—actions performed by him with incredible rapidity. If he does not do his business properly, he mars the work of the machine-minder—generally a *bigger boy*, and is apt to suffer the usual punishment, inflicted by the stronger work-people on the weaker, who happen to obstruct their labour, and their gain,—annoyance or oppression in some shape or other. If the difference of age and strength were the same between the machine-minder and the screwer, as between the slubber and piecener, in wool-spinning, there is little doubt that the ill-treatment which is in our factories now almost exclusively the reproach of the slubber, would find its parallel in a flax-mill. It appears to me that Mr. Wordsworth has intended that his machine should reduce the *minder* and the *screwer* to one person, and if he succeeds in his purpose he will be no less meritorious as a philanthropist than as a mechanic.

The machine-minder is by no means an idle boy;

\* John Elliot Drinkwater, Esq.

for, according to the usual mechanical arrangements, he has to move his strick, when it has received its due proportion of heckling in one position,—a circumstance announced in most cases by the tinkle of a bell—and has also to collect, from between the rows of revolving spikes, the tow or short fibrous matter combed off from the flaxen locks. Though the boys soon become expert at this business, a great many of them examined by the commissioners, had been wounded, sometimes severely so, during their noviciate. Here again, Mr. Wordsworth has shown how automatic invention is no less economical than humane, by attaching to his machine, as we have described above, brushes, cards, and doffer-combs, for removing the tow without manual intervention.

The *tow* is collected and carried to the card-room, a place more disagreeable with dust, in most flax-mills, than even the heckling-rooms. Great part of this evil seems to arise from not having the cards sufficiently enclosed. Were arrangements adopted for cleaning the tow by a blowing-machine, with dust suction-pipes, and for carding it by an improved engine, such as will be exhibited and explained in detail in our treatise on the cotton trade, the present nuisance might be almost entirely obviated.

The heckled flax, called *line*, when freed from the *tow*, is carried away to be sorted, according to its fibre, into various degrees of fineness; a task performed by young men called *line-sorters*. It is now at the same stage as long wool when delivered by the combers or combing-machine; and although both must be roved and spun upon similar principles, each requires peculiar modifications in its machinery. Girls, termed

line-spreaders, are employed to unite the locks of line into one sliver, exactly like the breakers in the worsted factories. It is thus prepared for roving and spinning.

Mr. Wordsworth has the merit of having contrived also an ingenious machine for roving and spinning flax on automatic principles, for which he obtained a patent, specified in January, 1833. The improvement which he claims, consists in a novel mechanism adapted to the travelling-comb called the *gill*, to enable its points to continue longer in action than in the ordinary construction of flax-machines, and to cause them to be withdrawn from the fibres at the end of the stroke, without the possibility of their tearing down the fibres with them. The manner of effecting these objects will be seen by reference to the two annexed wood-cuts.

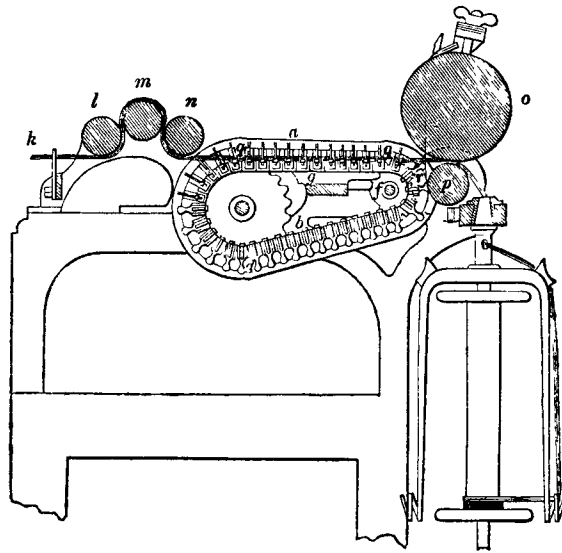

Fig. 40.—Wordsworth's Flax-roving Machine.

Fig. 40 is a longitudinal section taken through the middle of the machine; and fig. 41 is an improved

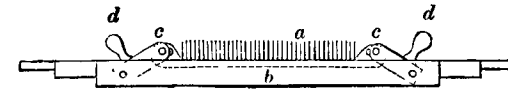

Fig. 41.—Wordsworth's Flax-gill.

gill detached, consisting of a row of heckle-teeth *a*, set in a metal bar, seen in dotted lines, with its double-jointed levers *d*, *c*, and carriage-frame *b*. When the heckles are in action on the *line*, their points are raised as in the figure, but they are sunk within the frame *b* by pressure applied to their jointed levers, in order to withdraw them from the flax. These two positions of the heckles are produced in consequence of the knobs or parts *d*, that project from the jointed levers *c*, acting against the edges of guide bars, as will be presently pointed out.

The several heckles so constructed, are made to work in the machine, by attaching each end of their respective frames *b*, to a travelling endless chain *e*, shown in the deep shade of the elliptic part. These two endless chains pass over fluted guide-rollers *f* (like those more obviously seen in the worsted-breaker p. 151), and over horizontal bars at *g*. These chains, with their heckle-mounting, are driven through the machine by revolving spur-wheels, the teeth of which take into the spaces between the cylindrical parts of the several heckle-carriages *b*, and thereby carry the heckles onwards.

If flax be passed into this machine by a feeding-cloth, called here a *creeper*, from its slow movement,



through a guide *k*, and be conducted first under and then over the feeding-rollers *l*, *m*, *n*, and over the heckles *a*, to the drawing-rollers *o* and *p*, and thence to the twist winding flyer and bobbin beneath, or to a receiving can, the fibres will be opened in their progress, and combed by the points of the heckles entering into and separating them; the lock being drawn with a different speed from that of the heckles.

It will be seen that the knobs *d*, fig. 41 which project from the jointed levers *c*, as they travel along the machine, bear against the outer edges of the two fixed guide-bars *q q*, that extend along the top of the machine in a parallel direction above the heckles, and by that pressure keep the heckle points raised as in fig. 41. But when the endless chains *e*, which support and conduct the carriage-frames of the heckles, have advanced the heckle points to within a very little distance of the drawing-rollers *o*, *p*, then the knob *d*, at each end of the heckle-bar, passes the confining ends of the guide-bars *q q*, and lets them immediately come in contact with two inclined planes *r* (one of them seen near *p*), and get thereby pushed, so as to depress the levers *c*, consequently to sink the heckle-bar *a* with its teeth within the carriage-frame *b*, and to withdraw them completely, in almost a perpendicular direction, from the fibrous material.

The heckles thus sunk, pass onwards in their bearing-frames with the travelling endless chains along the under part of the machine, and when they arrive at the back part of it, and begin to remount, the guide-bars *q q* being at their commencement slightly bent, conduct the knobs *d*, till they are forced back into their

primitive positions, and thus press up again the heckle-points into prominent action, the moment they come to the upper part of the chain-way.

This ingenious mode of depressing the heckle-teeth *a* into their hollow frames *b*, like the sliding of a comb into its case, prevents the *line* of flax from being torn down under the machine, as frequently happens in gill-machines of the ordinary construction as represented in the wool-breaker p. 151. The plan also of mounting the heckles, and carrying them along the chain-way by the guidance of parallel bars *q q* above, and inclined planes *r r* when they dip, allows the heckle-points to be brought much nearer to the drawing-rollers *o*, *p*, in consequence of the metal bars which hold the points falling below the central line of the endless chain *e*, as may be seen in the figure. Thus likewise means are provided of drawing and roving various qualities of flax, hemp, long wool, &c., and fibrous substances of a much shorter staple than them.

In spinning the rovings of the flax *line* into fine yarn, it is necessary to pass them through a trough of water, placed at the back of the spindles, in consequence of which a dewy spray is continually thrown off in the front of the frame from the yarn, as it is rapidly twirled by the fly of the spindles. And as another spinning-frame is placed at no great distance, the spinner is exposed to this small rain both in his front and rear; whereby he may, without certain precautions, have his clothes thoroughly soaked through in a few hours, especially if stationed between two frames set close to each other. The propriety, therefore, of separating each pair of frames to a suitable distance is

obvious, and has been properly insisted on by many visitors, more especially the factory commissioners and inspectors. It is, in fact, an instructive instance of avarice overreaching itself, by crowding machines into a space too small for them to be advantageously worked in;—a circumstance scarcely ever observed by me in any of the numerous cotton-mills which I entered.

The ill effects of this condensation are felt in two ways; first, in the exposure of the hands to discomfort, and the danger of being laid hold of and injured by the revolving wheels, and secondly, in the pollution of the air by a crowd of persons breathing in a small space. Perhaps the simplest form in which an enactment might be made by Parliament to redress this evil, would be to proportion the number of persons allowed to work in a room to the number of cubic feet contained within its walls; a principle acted upon in the law regulating the number of passengers per ton to the vessels which carry emigrants to our colonies. Annexed to evidence collected by Mr. Drinkwater, is a rough estimate, which shows that in some flax factories only twenty-five cubic feet are assigned as the space occupied by a spinning frame of one hundred spindles. In the two carding-rooms, the space occupied by the machinery would be greater than in spinning-rooms. A regulation which has reference merely to the height of the room, without considering its cubical contents, in comparison with the number of people who work in it, is insufficient. At any rate, both humanity and policy should make the adoption of such ventilating fans as Messrs. Fairburn and Lillie construct for purifying the air of cotton-factories, imperative on every proprietor of a flax-mill. They cost only four

or five pounds each, and are infallible specifics against in-door *malaria* in all conceivable circumstances. See Book III. Chap. 3.

It is my duty to state, that the proprietors of many flax-mills have not taken sufficient care to box off the dangerous parts of their machinery. “This remark,” says Mr. Drinkwater, “of course admits individual exceptions, though the number is very small of those mills in which, in my opinion, enough has been done in this way\*.” Since the appointment of the factory inspectors, indeed, extensive improvements have been made in this respect, as it gives them authority to require every reasonable precaution to be taken against the liability of unguarded machines to inflict injury on the work-people, and particularly the children, naturally heedless and daring from inexperience. “There can be no doubt,” subjoins Mr. Drinkwater, “that many, perhaps most of the accidents that occur in factories (of which, however, the number appears to me to have been greatly exaggerated), were, strictly speaking, the fault of the children themselves †.”

“I have not found the slightest ground for believing the statement, and I have more than usual difficulty in understanding how it could be believed by those who have made it, that any number of these accidents (in a general view of the question) has been occasioned by the *fatigue* of the children, arising from overwork. That such a thing may possibly have occurred, I am of course not prepared to deny; that it is a usual cause of accidents, I believe to be incorrect.

“Independently of the frames and other machinery

\* First Report of Factory Commissioners, C. I, p. 166.

† *Ibid.*, p. 167.

being set too close to each other, so as to make the alleys too narrow, there is often either too little or too much room left between the frames, &c., which stand side by side; that is, in the intervals which are occupied by the straps, fast and loose pulleys, coupling gear, &c. Many of these intervals are not meant for passages, and yet are sufficiently wide to induce the children, not without considerable danger, to use them. It has occurred to myself to be pulled back by a child as I was about to pass inadvertently through one of these passages, where I then saw I should have incurred much risk of an accident. Some very serious accidents happen in this manner, especially in the carding-rooms, where the machinery is of a larger and coarser description." \* All such sources of danger are, it is to be hoped, now in process of being removed.

Flax has been for a long period spun wet in the mills, a method no doubt copied from the practice of housewives moistening their yarn with their saliva at the domestic wheel. Within a few years the important improvement has been introduced, of substituting hot for cold water, in the troughs through which the fibres in the act of spinning pass. By this means a much finer, smoother, and more uniform thread can be spun than in the old way. The flax formerly spun to twelve pounds a bundle, is with hot water spun to six. The inconvenience of the spray thrown from the yarn on the flyers remains; aggravated by increased heat and dampness of the room, where this hot process goes on. Being a new expedient, it receives daily changes and ameliorations. When first employed, the troughs of

\* First part Factory Commission Report—C. 1, p. 167.

hot water were quite open; they are now usually covered in, so as almost entirely to obviate the objections to which they were previously liable. With the covers has been also introduced a new method of piecing or joining on any end, which may have been run down, namely, by splicing it to the adjoining roving, whereby it is carried through the water without imposing a necessity on the spinner to put her hand into the water at all. In some places she uses a wire, for the purpose of drawing through the end of the roving to mend a broken yarn.

This may be considered the inherent evil of flax-spinning,—the spray thrown off by the wet yarn, as it whirls about with the flyer of the spindles. A working dress, indeed, is generally worn by the spinners; but unless it be made of stuff impermeable to water, like Macintosh's cloth, it will soon become uncomfortable, and cause injury to health by keeping the body continually in a hot bath. In some mills, water-proof cloth and leather aprons have actually been introduced; which are the only practicable remedy, for the free space which must be left round the spindles for the spinner to see them play, is incompatible with any kind of guard or *parapluie*.

There was, before the late Factory Bill passed, a class of very young children employed in the flax-mills, under the name of little doffers, forming generally a troop of from four to ten in each spinning-room, who, the moment they perceived the bobbins of any frame or side of a frame exhausted of roving, ran together and furnished it with full ones as quickly as possible. They were not numerous in all, but they had an occupation requiring great activity and atten-

tion. It was practised also in the fine-spinning rooms, which are perfectly free from dust; and as it involved a kneeling and stooping position, seemed peculiarly appropriate to children, and is still done by them at a somewhat more advanced age.

The adjoining figure will serve to explain the me-

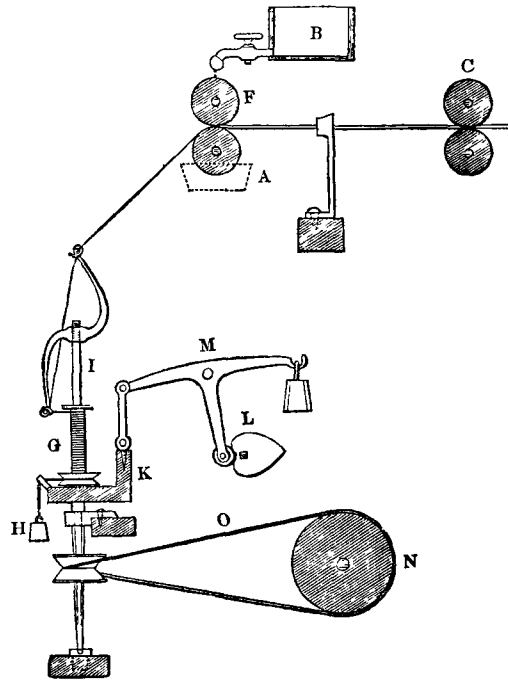

Fig. 43.—Wet Flax Spinning.

chanism by which the fine-spinning of flax is performed. The front pair of drawing rollers represented at F, was at one time moistened by letting water trickle upon it, from a vessel B, furnished with a stop-cock placed a little above, or by immersing one-half

of the under roller in the water-trough as at A. The roller-pair C, which receives the fine rovings from bobbins placed on skewers or upright pins in the creel behind, is so mounted as to be fixed at any desired distance from the front rollers F. This distance should be always a little more than the average length of the filaments of the line; for if it were equal to it, they would be seized at both ends by the two pairs of rollers which move with different velocities, and would be torn asunder, instead of being drawn out alongside of each other. The front rollers indeed move in many such machines four times faster than the back pair. The rest of this flax-spinning apparatus resembles in every respect the throstle-frame of the cotton-spinner. The thread as it escapes from the front rollers gets twisted by the spindle and flyer, and wound up in constant progression on the bobbin, the motion of the latter being retarded either by a washer of leather beneath its lower end, or sometimes, as shown in the figure, by a weighted lever H, suspended from a cord, which embraces the pulley-groove turned on the lower end of the bobbin. The friction of this cord on the pulley, which may be varied by changing the length of leverage at which the weight acts, gives the bobbin the requisite retardation for winding up the yarn.

The bobbin G, at the same time that it has this retarded movement of revolution on its axis, has another motion up and down on the spindle I, to present itself at different points to the thread, and to cause the equal distribution of this over the surface of the bobbin-barrel. This latter motion is given by a double eccentric L, which by turning slowly on its

axis, makes the balance-lever *M* oscillate, and thereby raises or depresses the bobbin-rail with its row of spindles. *N* is a section of the long tin drum, which extends the whole breadth of the frame, and communicates its rotatory motion, derived from the steam pulley, to the spindles, by the intervention of the endless cotton cords *O*, as also to the fluted rollers *C*, *F*, and to the axis of the heart-shaped or eccentric wheel *L*, working in an endless screw.

The ratio of the velocity of the rollers of supply *C*, with the front or delivering rollers *F*, and with the spindles, is proportional to the fineness of the yarn. For low numbers, the draught is usually four-fold. The speed of the spindles also varies with the quality of the yarn, according as it is intended for warp or weft; the former requiring more twist than the latter; but never so much as to cause it to snarl into a knot when left free to turn on itself.

Tow is carded by an engine perfectly similar to that already represented for carding short wool; is roved by a roving machine on the bobbin and fly principle used in the cotton manufacture, and is spun on a throstle-spinning frame, either with or without the application of moisture.

After the above description of the automatic system of flax-spinning, it may not be uninteresting to contemplate its origin in the self-acting household wheel.

Fig. 44 represents the domestic flax-wheel into which a certain self-regulating action has been introduced by Mr. Spence. *A B* is the bottom square board, supported on four feet, and carrying the two standards *C E*, *D F*, which bear towards the middle of their height, the crank axis *P V* of the wheel *G H* (seen

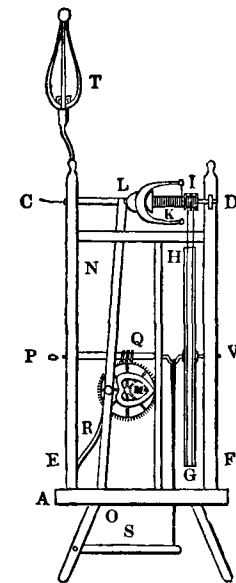

Fig. 44.—Self-acting Flax-wheel.

edgewise), and towards their upper ends the spindle, with its bobbin *C D*, which turns in leather-lined holes. *I* is a pulley or whorl fixed on the spindle, in the same vertical plane as the wheel *G H*. *K* is a bobbin set loosely on the spindle, one of the heads of which has a neck like the pulley, but of a diameter one-fourth smaller. The same endless cord goes round them both, which causes the bobbin to revolve one-fourth faster than the spindle. *L* is the winglet, which in turning along with the spindle, has the power of making it traverse and distribute the thread evenly over the surface of the bobbin. For this purpose, the lever *N* jointed at the point *O*, and embracing forkwise the head of the winglet, receives a see-saw move-

ment, by means of the eccentric M, attached to the toothed wheel, acted on by the worm-screw Q. A spring R keeps the lever steadily in contact with the eccentric or heart-shaped wheel.

The head of the spindle shown at C, and the winglet, are perforated, and receive through the holes in them the thread in its passage to the bobbin, round which it is lapped, in consequence of the above-mentioned difference of velocity between the spindle and the bobbin. S is the pedal, like the foot-board of a lathe, for turning the wheel. T is the distaff or rock for holding the flax intended to be spun.

---

## CHAPTER VI.

### *Nature and Operations of a Silk Factory.*

THE silk-worm is a precious insect, which was first rendered serviceable to man in China, about 2700 years before the Christian era. From that country the art of rearing it passed into India and Persia. It was only at the beginning of the sixteenth century that two monks brought some eggs of the silk-worm to Constantinople, and promulgated some information on the growth of the caterpillars. This knowledge became, under the Emperor Justinian, productive of a new source of wealth to the European nations. From Greece, it spread into Sicily and Italy; but did not reach France till after the reign of Charles VIII., when the white mulberry-tree, and a few silk-worms, were introduced into Dauphiny by some noblemen on their return from the conquest of Naples. No considerable result took place till, in 1564, Traucat, a common gardener of Nismes, laid the first foundation of a nursery of white mulberry-trees, with such success as to enable them to be propagated within a few years over all the southern provinces of France.

This insect, like all its analogous species, is subject to four metamorphoses. It is first of all an egg, which the warmth of spring brings forth in the form of a caterpillar; and this, as it enlarges, progressively casts its skin three or four times, according to the variety of the insect. This caterpillar at the end of

twenty-five or thirty days, having attained maturity of size, ceases to eat for the remainder of its life, merely discharges its excrementitious matter by spinning a cocoon or ovoid nest round itself, as a defence from enemies and external impressions, within which it is changed into a chrysalis or nymph; a sort of mummy state, in which the swaddled insect lies apparently dead for fifteen or twenty days. At length it bursts through its shrouds and comes abroad into the world provided with wings, antennæ, and feet. The male and the female, a couple of butterflies, now go together, under the generic name of *bombyx mori*, and terminate their brief union by death, after an average existence of two months.

The eggs or grains of the silk-worm are covered with a liquid, which glues them to the piece of cloth or paper on which the female is made to lay them; and they may be freed from it by dipping them in cold water, and afterwards drying them. They should be preserved at the temperature of from 54° to 59° Fahr. When the heats of April begin to be felt, they must not be suffered to act on the eggs, because they would bring on incubation before the first shoots of the mulberry have come forth to supply food to the young caterpillars. This period should be kept back also, because it is proper to hatch almost all the eggs together, or at least in successive broods corresponding to the extent of the breeding establishment. The eggs are tied up in flat packets, containing about an ounce in weight or a little more, which are hung to the girdles of the women in the south of France during the day, and placed under their pillows at night. They must be inspected from time to time when

so treated; or they may be laid in a stove-room, and exposed to a warmth gradually increasing till it reaches the temperature of 86° F., at which it must be kept stationary. Nature finishes the work of incubation in eight or ten days. The teeming seed is now covered with a sheet of paper pierced with holes, about one-twelfth of an inch in diameter, through which the young worms creep upwards instinctively to get at the mulberry leaves previously placed above.

Whenever the leaves become loaded with worms, they are transferred to plates of wicker-work covered with grey paper. This transfer is repeated twice every day. In the course of from forty-eight to seventy-two hours the whole of the eggs should be hatched. The nursery for breeding the worms is called *magnaniere*, and ought to be a well-aired apartment, free from damp, cold, and excess of heat, from rats and other destructive vermin. For breeding twenty-one ounces avoirdupois of seed, the chamber should be thirty-three feet wide by eighty feet long, and be provided with fire-places for heating and ventilating it. The window casements should be glazed. The temperature must not be allowed to fall under 66° F.; it may be raised to 92° F. or even higher; but from 68° to 86° F. is the ordinary range. A current of air should be admitted to purify the atmosphere from the fetid emanations of the caterpillars, their excrements, and the decayed leaves. Light is nowise unfavourable, contrary to the opinions of many persons; but may be regarded as in some respects advantageous.

The scaffolding of the shelves on which the worms are reared consists of as many pairs of standards, connected by horizontal bars, as the space requires, the

distance between the uprights being six feet. These are fixed at their ends to the floor and the ceiling. On the cross-bars, wickers, tablets, or mats are laid. The first range may be eighteen inches from the floor; the second fifteen inches above that, and so successively to the top shelf. A spare room should be set apart as an hospital for the diseased worms.

A few osier mats may suffice while the worms are young, but more are required in proportion as they grow larger, to prevent their getting piled on each other. The supply of leaves must be proportional to the age of the brood, and ought to be increased when nothing but their ribs are left. The very young should be fed with leaves minced small, and should not be troubled with the removal of the litter which is trifling. At a future stage it must be removed with delicacy, to give the worms more air, on the new wicker frames, without however parting them too far. Before each moulting, the worm has a keen appetite, but during that process it loses it entirely, and falls into a languid state, from which it immediately revives on casting its skin.

The pieces of paper are withdrawn from the bottom of the wicker frames to permit a freer transmission of air between their interstices, whenever the worms have become large enough not to fall through them. After the second moulting, they are half an inch long, and may then be transported from the smaller apartment, in which they are hatched, into the larger one, where they are to be reared to maturity. They must be well cleansed from the litter on this occasion, laid upon fresh leaves, and supplied with a succession of them, cut in pieces, every six hours. To change or make their bed, a net-work is laid over the wicker

tablet, and covered with leaves, when the worms creep up upon them, and may then be lifted with the net, so as to allow the litter to be cleared away, and the sick to be removed without touching the sound ones with the hand. They are then laid down again, with their nets, or they may be replaced on the wicker-work, by moving the leaves which they are gnawing. The breeding-room should be freed from the offal most carefully, and kept extremely clean and dry. After the third moult, the worms may be fed with entire leaves; for they are then extremely voracious, and must not be stinted in their diet. The same remark is still more applicable to the period after the fourth moult. The heat should now be limited to 68° or 70° Fahr.

In every period of their existence the silk-worms are liable to a variety of diseases, under which they derive benefit from the exposure of portions of chloride of lime in their nurseries. When they have reached the fifth stage, they cease to eat; they void their excrements, diminish in bulk, become somewhat semi-transparent, abandon the leaves, try to crawl on the upright posts, and to conceal themselves in corners. These symptoms indicate the development of the spinning instinct. Twigs of heath, broom, green oak, or privet, are now to be laid in parallel rows on the wicker tablets, in the form of little alleys, eighteen inches wide, with their little ramifications interwoven above. The worms of two tablets are to be collected on one, and freed from all their litter. Little coils of paper, of wood shavings, tufts of couch grass, are placed alongside of the diligent worms first, and, after awhile, of the lazier ones. The creature sets itself to construct its cocoon, throwing about its thread in



different directions, forming the floss, filoselle, or outer open net-work. But it soon begins its regular operation of winding round-about, in nearly parallel lines, a fine thread into an egg-shaped form, in the centre of which the caterpillar sits at work.

The matter of the silk is liquid in the body of the worm, but it hardens in the air. The twin filaments, which the animal always spins through its double tubular mouth, are agglutinated by that liquid cement. The same matter may be extracted in a lump from the body of the worm, and drawn out artificially into a thin transparent web, or into threads of variable diameters. The cocoons are completed in the course of three or four days, after which they must be removed from the branches and sorted, the finest being reserved for seed-worms. Out of these cocoons, at the natural age of eighteen or twenty days, the butterfly is developed: it perforates the cocoons, by knocking its head forcibly against one end of its tomb, which it has previously softened with moisture, to facilitate its tearing the filaments asunder with its claws. These butterflies or aurelias are collected, and placed on an old piece of soft cloth of any kind, where they couple and lay their eggs.

The cocoons which are to be unwound must not be allowed to remain with the worms ten or twelve days alive within them; for if the chrysalis has time to come out, the cocoon would get cut through, and be useless. The animal must be therefore killed by suffocation, which is effected either by exposing the cocoons for five days to the sunshine, by placing them in a hot oven, or in the steam of boiling water. A heat of 202° F. is sufficient for destroying their

vitality, and this may be best given through the medium of hot water, surrounding tin cases filled with the cocoons.

It has been ascertained that fifteen parts by weight of mulberry leaves furnish one part of cocoons, and that one hundred of cocoons furnish eight of reeled silk. Under favourable circumstances, one ounce of seed-eggs will produce eighty pounds of cocoons, and even more. One pound of cocoons is required to yield one ounce of eggs. The silk of a cocoon weighs two and a half grains, and affords a length of thread equal to from 750 to 1160 feet.

The coils are agglutinated by a species of gum, from which they must be loosened with hot water, to allow the thread to be unwound to its end. This operation is called the winding of silk.

The cocoons are placed in a flat basin of copper filled with water, heated by means either of a stove or a steam-pipe. The filaments of several cocoons are usually wound off together into a compound thread; and they are freed from any slight adhesions by a little pointed brush dexterously applied by the winder, in their progress to the reel.

There are three kinds of raw silk, organzine, tram, and floss. Organzine is used for the warp of silk goods, requires the best quality of silk, usually contains from six to eight filaments in one thread, and it receives a considerable twist to make it strong and free from flocky points. The tram is made from inferior silk, and consists of ten or twelve filaments slightly twisted together.

Raw silk threads consist sometimes of three cocoon filaments and sometimes of thirty, which are compacted

in various degrees. Each cocoon filament gradually diminishes in size and strength from the circumference towards the centre of the cocoon, because since the worm takes no food from the moment it begins spinning, it consequently becomes gradually feebler in its progress, and exhausts the material of its silk. The winder must attend to this attenuation of the filaments, and make up for it as occasion may require by the addition of fresh cocoons. The water employed for softening the cocoons should be pure, and especially free from calcareous salts, otherwise it might have an indurating influence on the gummy varnish, instead of softening and removing it. On the skill of the winder the quality of the silk very particularly depends.

Silk is a very hygrometric substance, and will absorb as much as ten per cent. of moisture. This property has been sometimes fraudulently employed to increase the weight of silks offered for sale. In case of suspicion, weighed portions of the silk should be enclosed in a wire-cloth cage, and exposed to a gentle stove-heat; when they will show by their loss of weight the extent of the fraud.

The French raw silk brought to market obtains on an average from twenty to thirty sous (10*d.* to 1*s.* 3*d.*) per pound more than the Italian of the same fineness. The silk district of France lies on the two sides of the Rhone from Lyons, the northernmost point, and includes thirteen departments of the kingdom. The white mulberry-tree is injured by grafting. Only one crop is gathered from it in France each year. A dry, upland, and not very rich soil is advantageous to its growth.

There are two species of silk-worms reared at

present; that which casts its skin three times, which is a small worm common in Lombardy, and is the one preferred by Dandolo, because it completes its task in four days less; and that which moults four times and is the worm originally bred in Europe. The second kind of worm lives from thirty-five to thirty-seven days, according to temperature; the first four days less. The worm in the course of its existence increases in weight 30,000 times from the egg; and its development is watched by many of the peasants who educate them with scientific care, with the aid of the barometer, thermometer, and hygrometer, instruments familiar to the French people, in consequence of their gratuitous schools of science, though hardly known even by name to the English.

One test of the excellence of the chrysalis for affording seed or eggs, is the hardness of the ends of the cocoons.

The silk crop, as it may be called, is completed in about six weeks from the end of April, when the hatching season begins; it is therefore the most rapid of natural productions, and requires little advance of capital for the purchase of the mere leaf. In purchasing the cocoons and in reeling off the silk, indeed, capital may be often laid out with advantage. As there is a large proportion of the public revenue raised in France from the general land tax, there is no tax on mulberry-trees as there is in Italy.

Bonafons gives the following curious table of the progress of the worms hatched from one ounce of eggs, from birth to the time of spinning. In the first age, they consume seven pounds of leaves; in the second, twenty-one; in the third, sixty-nine pounds

English pound; except on India silk, which is only  $2\frac{1}{2}d.$  per lb. The prices of the best French silks are generally ten per cent. higher than those of similar Italian silks. In Zurich, where thrown silk is imported free of duty, there were only 1000 looms in 1792, and there are 12,000 at present.

Those who have of late years sent the thrown silk from Italy to England have in general lost by the throwing process. "Comparing the English with the Italian throwster, I should say, the English has perhaps the better chance of the two in the selection of silk, because when the English throwster wishes to make a purchase, he has the produce of all the different countries of Italy before him to make his selection; the Italian has only the silk of his own country before him, as Fossombrone, Naples, &c., and not that of the other States. I do not understand what is meant in Mr. Brockwell's evidence by local advantages, nor do I see on what ground it can be that the foreign throwster has the advantage, as has been stated, of  $3s. 6d.$  over the English throwster. I do not see that he has any\*."

The late failures among the English throwsters may be ascribed to their want of sufficient capitals in a trade so susceptible of variation from the caprices of fashion, and from the fluctuations of the money market. As long as it is a remunerating trade they can go on, but the moment a check comes, they fail, from being unable to support the business till a reaction comes round. Many persons in fact set up mills without having the least means of resisting the pressure of trade†.

\* John B. Heath, Esq., Select Committee on Silk Trade, 1832, p. 306.

† *Ibid.*

The temperature of the air, and general state of the weather, have a great effect on the filature and spinning of silk; and they are both favourable in Piedmont. In the throwing department great pains have been taken by the government of that country in the proper examination of the organzine, with a view of preserving its character.

At Lyons, in 1832, the cost of throwing organzine of twenty to twenty-two deniers was  $4s. 4\frac{1}{2}d.$  the English pound, waste 10 per cent. included.

At Bergamo, which is a principal place for throwing silk, the cocoons are bought in open market and by private contract, three or four months before the crop is ready. Some purchasers advance one-third of the price to the producers, and then they send the cocoons to the reelers. The landlord of the grounds where the mulberry-trees are grown from seed, supplies leaves and cocoon eggs to the silk-worm rearers. It requires five or six years to bring the mulberry-tree to perfection; and leaves cannot be gathered before it is three years ingrafted. The leaves of a seven years old tree are worth  $1s.$  per annum, and of one thirty years old,  $30s.$  There is a sort of partnership between the landlord and the labourer in this business; and one-half of the profits goes to each. A rubo of cocoons requires for their production 100 rubos of leaves. The crop is over in June, when the reeling begins and goes on till September, or even October, if the season be favourable.

The expense of reeling silk from three to four cocoons, is from six to seven Italian livres; and from four to five cocoons, six livres the pound. That of the

three to four cocoons, will be twenty to twenty-four deniers; the four to five, will be twenty-four to twenty eight; and the five to six, twenty-six to thirty-two according to the quality of the cocoons. The Italian livre is worth  $7\frac{1}{2}d.$  English. The woman employed at the boiler receives one livre and five sous per day with bed and board; and the girl who turns the reel gets thirteen sous per day, also with board and lodging. In June, July, and August, they work sixteen hours a day, and then they do a rubo or ten pounds weight of cocoons, which yield about two pounds of raw silk. Later in the year, when the days are shorter, they do little more than half a rubo; and receive two-thirds the former wages. The whole expenses, inclusive of rent, taxes, repairs, &c., will amount to from six to seven livres on each rubo; the livre containing twenty sous; being about  $2s. 6d.$  or  $2s. 10d.$  the English pound. The charges for throwing tram, including winding, doubling, twisting, and waste, is  $1s. 3d.$  the Italian pound of twelve ounces; but there is 3 per cent. of waste. That would be  $2s.$  the English pound, independently of the duty on export, amounting to  $3\frac{1}{2}d.$  the Italian pound.

The cost of throwing organzine is  $1s. 10\frac{1}{2}d.$  the Italian pound, besides 5 per cent. of waste; or  $3s. 6\frac{1}{2}d.$  in English weight, including the export duty of nine sous on coming out of Lombardy. The number of deniers of that silk may be taken on an average at from twenty-four to twenty-eight deniers. This is the average charge to the person sending the raw silk to the throwster. The throwsters work only eight or nine months in the year. The charges in Piedmont for throwing are ten or fifteen sous more than in Lom-

bardy, because the exportation of raw silk is not allowed there, and it must be put into the throwster's hands almost on his own terms. It is better thrown however in Piedmont, in consequence of the government regulations. The throwing-mills do not work all the year round, because the raw silks find better prices in England and France. In fact there are not mills enough to throw half the silk produced in Italy. The advantage to the throwster in working the silk fresh from the cocoons is inconsiderable.

Mills to throw from 10,000 to 12,000 pounds (Italian) per annum, may, it seems, be rented at from  $60l.$  to  $90l.$  sterling, on a lease of nine years; and they are worked by water. The people, who are almost all females, are prejudiced against machinery, and do the principal part of the work by hand. Their board costs  $8d.$  a day. The winders have no machinery except the swifts, one set of which costs no more than  $30s.$  The working of such mills rent-free is a folly.

A girl will double in the factories twenty pounds per week; and is paid ten sous for every pound, or nearly  $1s.$  a day, working fourteen hours. The twisting and throwing processes are done by men with the assistance of a few boys; one man usually turning off a little less than twenty pounds each week, somewhat less in winter than in summer. He receives thirteen sous per pound, or  $8s. 1\frac{1}{2}d.$  a week, working from fourteen to sixteen hours daily. The men work by the piece, and have no board. Each performs the distinct operations of twisting and throwing twenty pounds, the doubling which is an intermediate process, being performed by other hands. The silk is brought into the mill after having been wound in private houses; it

is first twisted, then doubled, and lastly thrown. The proprietor of the silk pays the expense of the carriage from the filatures to the mill, and back again; but it is trifling. The persons engaged in this trade in Italy vary as to their wealth: if they are thriving, as some say, why do they not multiply their mills?

A bale of organzine of 240 lbs. English, pays in England a duty of 42*l.*, and 7*l.* 14*s.* more in charges of transport from Italy. The whole costs, including brokerage, amount to 25 per cent. on the value of organzine; and 13 per cent. on that of tram. There is a difference of 12 per cent. on the charges, including duty, on thrown silk imported into this country, more than on raw.

The throwing in Lombardy is not likely to be increased, because it is ill-done, and gives no profit. Besides, the raw silk always bears a higher relative price than the thrown does in Italy, because it is fit for any market; but when once thrown it can be sold only for certain purposes. For this reason, raw silk is cheaper now in London than in Italy\*. The silk-looms at Milan and Como do not exceed 2000 in number, and they are used chiefly as a cloak to introduce, by smuggling, the French and English manufactures, which are prohibited in Lombardy.

Mr. R. Baggally, a partner of a great house engaged in the trade of ribbons and broad silks, says, "that in 1829, out of every 100*l.* worth of sarsnet ribbon that they sold, 52*l.* 10*s.* were English, and 47*l.* 10*s.* Swiss; and that in 1832, 92*l.* 7*s.* 6*d.* worth were English, and 7*l.* 17*s.* 6*d.* Swiss." In May of the latter year, they were ordering no Swiss at all, as they

\* Mr. Francesco Cuffi.—Committee on Silk Trade, 1832, p. 410.

thought they could do better at home in consequence of the fall of prices at Coventry. The English ribbons are not only 20 per cent. cheaper, but much better than they formerly were. The French ribbons are inferior to the Swiss. The duty on importation is fully 25 per cent. "Independently of duty, I believe that we can purchase lustrings and satins cheaper in Coventry than in France\*." In mechanical execution, the English equal the French, but not in the fashion and the style of the articles. The English colours however are decidedly more permanent than the French.

In our single-hand ribbon-loom, the weaver can make but a piece and a half a week; while in the engine-loom he can make six pieces. Five shillings a piece was paid the engine-loom weavers in the winter of 1831-2; but these looms were not common, on account of the prejudices of the workmen. As to broad silks, Mr. Baggally says, he can buy as good gros de Naples in Manchester as he can in Lyons, at the same price; that is, for the great bulk of the consumption from 2*s.* to 3*s.* 8*d.* per yard. "I think that Spitalfields would have gone on increasing; but that they have given their trade away to Manchester †."

The silks made at Macclesfield are bandannas, black handkerchiefs, Persian sarsnets, gros de Naples; with which the French goods come into no competition whatever. Spun silk may be purchased at Macclesfield for 3*s.* a pound woven into bandannas, and receives a bounty on exportation of 3*s.* 6*d.* The Spitalfields velvets are improved so much in fineness and in pre-

\* Mr. R. Baggally.—Committee on Silk Trade, 1832, p. 414.

† *Id. Ibid.*

erving their colours, that many persons will not now buy foreign velvets. German velvets would be preferred by some, were it not for the duty, which is so high as 46 per cent. on broad articles, and 62 on ribbon velvets. The rate of smuggling insurance was, in 1832, 17½ per cent., leaving a great inducement to the contraband trader. The smuggler could not be indemnified at a lower per centage.

The purchases of silk goods by the house of James Morrison and Co., amounting to several millions value, show, that up to 1829 the proportion of French articles to English increased, and that since 1829 it has decreased in the ratio of forty-four to fifteen. On their latest purchases of silk goods to the amount of 1,000,000*l.* sterling, 4½ per cent. only were French. In broad silks, this house has made no French purchases for a considerable time past, because they could not sell them, in consequence of the great improvement in the English manufacture. They have not lately imported velvet ribbons from the Continent, because they can buy English ones cheaper.

The silk trade of Great Britain at present may be valued at 7,000,000*l.* sterling; the silk importations from France throughour Custom-house, amount to from 450,000*l.* to 500,000*l.*, and by smuggling, to 250,000*l.* or 300,000*l.* more, making in all from 750,000*l.* to 800,000*l.* If the silk manufacturers' invoices through-out this kingdom for one year were added together, their selling price to the warehousemen would be from 6,000,000*l.* to 7,000,000*l.* The ribbon manufacture of England amounts to from 800,000*l.* to 1,000,000*l.* annually; and that of France to 1,300,000*l.* The purchases of English silk goods by the house of James

Morrison and Co., have increased very much of late years.

The value of the 4,200,000 pounds weight of raw silk manufactured in France has been estimated at 140,000,000 francs, or 5,600,000*l.* sterling; of which goods equal to 110,000,000 francs, or 4,400,000*l.*, are exported, and only 1,200,000*l.* worth retained for internal use; being probably not more than one-fifth of the home consumption of the United Kingdom.

The declared value of all our exported manufactured silks last year, was only 636,419*l.* If this sum be deducted from our total manufacture, 7,000,000*l.*, the remainder 6,363,581*l.* will denote the value of the silk goods retained for use—a value which may, in round numbers, be fairly rated at six millions sterling. Thus it would appear that the female inhabitants of this country can afford to spend five times more money upon the luxury of dress than those of France, who are one-half more numerous, and not less vain. This fact affords a striking proof of the relative *aisance*, or means of comfort enjoyed in the two countries.

To make organzine, the thread of raw silk is first twisted, and two of these threads are then united by twisting. In the process of making tram, the original single thread is not twisted at all, but two of them in their simple state are softly twisted together. Thus, in organzine, there is a compound torsion for giving firmness to warp threads, and in tram there is a single torsion, of only such a degree as to make the thread bear the tension of throwing it by the shuttle across the web. In warp, there are sixteen twists on the single thread, and from twelve to fourteen on the double. On looking through tram suspended in a

good light, its want of twist in the component threads is very visible.

There is a peculiar kind of silk called Marabout, often with three threads, made from white Novi raw silk. Being white as it comes from the worm, it takes the purest and most delicate shades of colour at once, without the discharge of its gum. That silk is first thrown into tram, and then sent to the dyer. When dyed, the throwster re-winds and re-throws it, and thereby converts it into marabout, a thread twisted hard like whip-cord. The cost of the raw Novi silk is 19s. 6d. a pound; of throwing it into tram, 2s. 6d.; of dyeing, 2s.; of re-winding and re-twisting it after it is dyed, about 5s.; of waste, 2s., or 10 per cent.; the total of which sums is 31s., being the price of a pound of marabout in 1832.

When raw silk can be bought in Italy for 17s. 6d., it can be bought in the thrown state for 3s. 9d. more. The best raw silk is generally thrown in Italy, and the worst is usually sent to this country. The Italian throwster has, some say, a decided advantage over the English in the power of selecting his raw silks in the first market. The difference in the quality of raw silk will make a difference of 9d. or 1s. in the expense of throwing. This is denied by other authorities.

The Fossombrone silk is of very good quality, and is that which comes all in the raw state to this country, because that district in Italy has no throwing-mills.

Organzine has its pair of threads twisted together the opposite way from the twist of the separate threads. It is only a finishing degree of twist which marabout receives after dyeing. When organzine costs 3s. 6d. to throw, the marabout costs 7s. 6d., and tram 2s. 6d.

Machinery which will throw 100 lbs. of the fine Italian silk, will throw two or three hundred of the coarser kinds. The protection now given by law in France against the Italian throwster is 10½d., and that in England is 3s. 6d., which is reckoned equal to our whole expense of throwing one pound.

In 1832, Mr. V. Royle, who gives work to from 4000 to 5000 persons, stated in evidence to the committee on the silk trade, that the number of looms then employed in Manchester on silk and mixed silk goods was about 12,000, of which two-thirds were silk alone. "In 1819," says he, "there were not above fifty looms in that town for weaving broad silks for garments; and if Mr. Huskisson had not in 1824 brought about a change of system by lowering the import duty on raw silk, which was then 5s. 6d. a pound, there would not have been now any silk trade for the Spitalfields people to quarrel about." This statement is disputed.

There was then a power equal to 342 horses engaged in the silk throwing-mills of Manchester. Value of the whole at least 200,000*l.* He thinks the appointment of that committee had injured the trade, by making the shopkeepers afraid to make purchases of goods for fear of a fall in price. The worst silk-mill is in his opinion worth more in old materials than all the reeds and harness in Spitalfields. In a mill which costs 4000*l.*, one thousand pounds are paid to the king for taxes in the building materials; bricks, wood, and glass. The wages of work-people in the silk throwing-mills of Italy are about one-half of the wages in Manchester, but the difference is fully balanced by the protecting duty of 2s. 10d. per pound, deducting the deventure, and 'by our very superior machinery.

In 1830, an Italian silk throwster came to Manchester with a correct plan of his mill, and purchased several frames of the first description, which were sent after him to Lombardy; but I question very much whether he will work them to advantage.

After the reduction of the duty upon thrown silk, in 1825, to 5s., the quantity imported next year fell to 289,000 lbs., from the former average for ten years of 400,000; and in 1829, it fell to 172,000. These facts show the use of competition in quickening the industry of nations. The total quantity of silk produced in all Italy, is stated by Mr. Brockwell to be no less than 7,000,000 of English pounds, of which 5,500,000 are thrown in Italy. The Italian raw silk seems to be going lower in the rate of imports into this country. On an average, about 1,250,000 lbs. of it come into England, and 250,000 into France and Switzerland. To Vienna and Italy 2,000,000 of thrown silk may be apportioned; to France about 1,000,000, and England 500,000. In 1831, we consumed 428,475 lbs. of organzine, and 90,770 of tram silk. There has been a large increase in our importation of foreign tram silk; the duty upon it being only 2s. per pound.

The French silk trade is at present labouring under very considerable disadvantages; chiefly from the withering influence of their general prohibitory system. There is first a heavy tax on raw silk, to protect the home grower of silk; there is an enormously heavy tax upon iron to bolster up their tottering iron-masters; hence the price of wood also has been raised, and both causes have increased the cost of their machinery; and in the great towns, the local taxation is very heavy, so that all manufactures for which taste and

long experience do not give some peculiar facilities, are upon the decline. The weight of silk imported for the consumption of France was, in 1829, 1,021,867 lbs.; in 1830, 700,866; and in 1831, only 524,780.

The amount of the silk manufacture of France in 1832, was estimated at 140 millions of francs, of which 110 millions are exported, and 30 millions consumed in the country, and the general calculation is, that 80 millions of that amount consist in raw material. If 20 francs per pound be taken as the average value of that material, four millions of pounds will represent its total weight; from which, deducting one million of pounds imported, there remain three millions for the produce of the silk-worm of France.

There are 70,000 silk-loom in France, working up annually an average weight of 60 pounds; the product of the two numbers multiplied together gives 4,200,000, in confirmation of the preceding estimate.

The silk of Cevennes, in France, is perhaps the finest in the world. One kind of it fetches 18s. 5d. the English pound; and another 19s. 1d. at Lyons. There is a little still finer, which brings 2l. sterling. The estimate of silk worked up per English loom in a year, is above 60 lbs.; but the labour in this country is steadier than in France. Four hundred thousand pounds of silk of superior quality were grown in Cevennes in 1832, and this quantity has been much on the increase; as among all employments of capital, none is so productive as the mulberry-tree. It was yielding at the above period, from 15 to 20 per cent. profit to the intelligent agriculturist.

An ounce of silk-worm eggs in France is worth two francs and a half, and it will require for its develop-



ment and growth into cocoons, 1500 weight of mulberry-leaves, the average cost of which is about three francs per cwt. in a good year. One ounce of eggs will produce 100 pounds of cocoons, of the value of a franc and a quarter per pound, or in whole 125 francs. These 100 pounds of cocoons will yield eight pounds of silk, at a medium price of 18 francs. The average rate at which women reel off the cocoons is 25 pounds per day, or two pounds of silk; for which they receive in wages from 30 to 40 sous; that is, from 15*d.* to 20*d.* One hundred pounds of the coarser silk cocoons will give one-tenth, taking in the whole silk district. One mulberry-tree will afford about one cwt. of leaves; though there are trees which have produced 30 cwt. The cost of cultivation is reckoned at one franc a hundred weight, which leaves a large profit in selling them to the peasants who "educate" the worms. Some purchase the eggs, and cultivate themselves the mulberry-trees. The cost of a mulberry-tree varies from 6*d.* to 10*d.*, and it is planted out at four years of age. The peasantry will generally contract to plant them out at 8*d.* the tree; they begin to strip them in the fifth year, and find an increasing produce up to the twentieth year.

Price of Cocoons and Raw Silk of Cevennes at the period of Harvest during 10 Years.

Years.	Price per Alais lb. Cocoons.	Price per Alais lb. Raw silk.
1822 . .	1.70 francs. . . .	31 francs.
1823 . .	1.50 . . . .	22.25
1824 . .	1.40 . . . .	23.00
1825 . .	1.70 . . . .	28.00
1826 . .	1.70 . . . .	25 00
1828 . .	1.50 . . . .	23.25

1829 . .	1.45 . . . .	23.00
1830 . .	1.40 . . . .	22.50
1831 . .	1.35 . . . .	20.50

The Cevennes silk is reckoned to afford 1 lb. from 13 lbs. of cocoons, reeled at from four to five cocoons per thread, and to cost in winding or reeling 3 francs 50 cents. The Alais pound is about 92-hundredths of the English avoirdupois pound.

The fineness of silk is ascertained by winding off 400 ells, equal to 475 metres, round a cylinder one ell in circumference, and weighing that length. The weight is expressed in grains, 24 of which constitute one denier; 24 deniers make one ounce; and 16 ounces one pound, poids de marc, which is the Lyons mode of selling silk. The weight of one thread of 400 ells, is about 2½ grains, when five threads are reeled together. Before sales are effected in France, the silk is submitted to a temperature of about 78° Fahr. in a stove for twenty-four hours, or till it loses less than 2½ per cent. in a day. On the certificate of weight from this drying-office, called *the Condition*, the invoices are made out. I believe that no such experiments take place in this country; but in France they are objects of extreme attention, and are quite essential to protect the manufacturer against frauds. All the silk submitted to the *Condition*, however, must be worked up into French fabrics\*.

The great development of the silk manufacture in France is mainly owing to its being the least protected interest in that kingdom. Its spontaneous growth, being fostered by the native taste of the people, has given it stability at home and a steady demand

\* See note C, at the end of the volume.

over the whole world. As foreign silks are admitted at a moderate duty, they continually stimulate to fresh improvements and suggest endless variations of style. The opinion generally entertained of the superiority of such French silks as are figured, and which depend for their beauty on tasteful arrangements, is no more a prejudice of mankind, than the feeling in favour of the works of Raphael and Titian. In the manufacturing texture, the prepossession however is in favour of Great Britain, on account of our superior machinery. Taste descends to the lowest classes of the community in France, in remarkable contrast with the neglect of it among the lower orders of our countrymen. Taste is, in fact, an abundant and cheap commodity across the Channel, it is rare and costly on this side of it; a circumstance due very much to the pains taken by the French government for a century and a half to encourage the Fine Arts, and to exhibit specimens of them freely to the people, in public buildings, all over the kingdom. Gratuitous schools of design also are established at Paris, Lyons, and many of their principal towns. Taste is displayed both in the forms and grouping of the figures, and the disposition of the colours. The artist creates objects of taste with a brush and a few pigments, independently of the quality of the canvass or ground on which he lays them. The canvass may be equally good in England and in France, but when enriched by figures, it derives its value from the tastefulness of the decorations.

The amount of protection by duties in France may be estimated at from 15 to 17 per cent. on foreign manufactured silks. The protective duty in this

country was calculated to be 30 per cent.; but it is effectively 35 at least, according to Mr. Dillon's evidence before the Silk Committee of 1832. One of the leading manufacturers of Lyons informed Dr. Bowring, that the importation of foreign silks was a great source of the prosperity of their home manufacture; that, for instance, a number of foreign crapes being sold at a low rate, and carried into general consumption, had induced the Lyonnese to take up the crape trade in earnest, and to make it now one of their most important branches. The silk manufacture in France is the only one which stands on its own legs, an exception to the vicious system of protection, so prevalent in that country, and hence it is the only one at this time which is not in considerable distress,—a hopeless distress, to which there is no parallel in any of our manufactures. The silk is, in fact, the only manufacture which grows under the salutary breeze of competition with the foreigner; and it is indebted for many of its improvements to the invention of other countries. The bar-loom, when it was introduced some years ago for weaving ribbons, would have remained neglected but for the pressure of Swiss competition.

The history of the introduction of the Jacquard-loom is a most instructive lesson on the advantage of free intercourse and rivalry between different countries. The inventor of that beautiful mechanism was originally an obscure straw-hat manufacturer, who had never turned his mind to automatic mechanics, till he had an opportunity by the peace of Amiens of seeing in an English newspaper the offer of a reward by our Society of Arts, to any man who should weave a net by machinery. He forthwith roused his dor-

mant faculties and produced a net by mechanism ; but not finding the means of encouragement in the state of his country, he threw it aside for some time and eventually gave it to a friend, as a matter of little moment. The net, however, got by some means into the hands of the public authorities, and was sent to Paris. After a considerable period, when Jacquard had ceased to think of his invention, the prefect of the department sent for him, and said, " You have directed your attention to the making of net by machinery ?" He did not immediately recollect it, but the net being produced recalled everything to his mind. On being desired by the prefect to make the machine which had led to that result, Jacquard asked three weeks' time for the purpose. He then returned with it, and requested the prefect to strike with his foot on a part of the machine, whereby a mesh was added to the net. On its being sent to Paris, an order was issued for the arrest of its constructor, by Napoleon, in his usual sudden and arbitrary way. He was placed immediately in charge of a *gendarme*, and was not allowed to go to his house to provide himself with necessaries for his journey. Arrived in the metropolis, he was placed in the *Conservatoire des Arts*, and required to make the machine there in presence of inspectors ; an order with which he accordingly complied.

On his being presented to Bonaparte and Carnot, the former addressed him with an air of incredulity, in the following coarse language:—" Are you the man who pretend to do what God Almighty cannot do, to tie a knot in a stretched string ?" He then produced the machine and exhibited its mode of operation. He was afterwards called upon to examine a loom on which

from 20,000 to 30,000 francs had been expended for making fabrics for Bonaparte's use. He undertook to do, by a simple mechanism, what had been attempted in vain by a very complicated one ; and taking as his pattern a model-machine of Vaucanson, he produced the famous Jacquard-loom. He returned to his native town, rewarded with a pension of 1000 crowns ; but experienced the utmost difficulty to introduce his machine among the silk-weavers, and was three times exposed to imminent danger of assassination. The *Conseil des Prud' hommes*, who are the *official* conservators of the trade of Lyons, broke up his loom in the public place, sold the iron and wood for old materials, and denounced him as an object of universal hatred and ignominy. Nor was it till the French people were beginning to feel the force of foreign competition that they had recourse to this admirable aid of their countryman ; since which time they have found it to be the only real protection and prop of their trade.

The bar-loom was a Swiss invention brought into the neighbourhood of St. Etienne by two brothers. They were persecuted for their pains by the ribbon-weavers of the old school, and driven forth into the extremity of misery. The last of them died not long ago in an hospital, a victim of neglect and annoyance. Of late years, however, this loom has become a favourite mechanism, and is in almost universal use among the weavers of the very district where it was long an object of execration.

The silk-trade of France labours, as we have said, under a disadvantage in the construction of its machinery, from the false protective system so prevalent in

that country; whereby it pays a duty of from 15 to 33 per cent. on its importation, to protect the machine-maker; who in his turn has to pay for the protected French iron 150 per cent. more than he could for the English; and in like manner more for his timber, to protect the wood-grower. The towns of France are subject to oppressive taxes which fall peculiarly on the labourers; such as town dues on food, drink, and fuel. Hence, the weavers of Lyons and St. Etienne are now in process of migrating to the mountains, at no little inconvenience to trade. Many of the intelligent manufacturers of these towns are also under considerable alarm at the progress which the silk manufacture, with all our advantages of machinery and commerce, is now making in England. The total number of looms at Lyons, was, in 1832, 25,000, of which one-half was within the walls, and one-half without. The importation of English silks into France increased six fold between the years 1828 and 1830; amounting, in the first year, to the value of 119,570 francs, and in the last to 643,720 francs. It consisted chiefly of bandanna handkerchiefs, not of oriental make, but woven in this country.

It is in the production of the patterns of silk goods, that the French have a decided advantage over the British;—they probably have little or none after the design is put into the loom. The modes in which taste is cultivated at Lyons deserve particular study and imitation in this country. Among the weavers of the place, the children, and everybody connected with devising patterns, much attention is devoted to every thing any way connected with the beautiful either in figure or colour. Weavers may be seen in their holiday leisure gathering flowers, and grouping them

in the most engaging combinations. They are continually suggesting new designs to their employers; and are thus the fruitful source of elegant patterns.

There is hardly any considerable house in Lyons, in which there is not a partner who owes his place in it to his success as an artist. The town of Lyons is so conscious of the value of such studies, that it contributes 20,000 francs per annum to the government establishment of the School of Arts, which takes charge of every youth who shows an aptitude for drawing, or imitative design of any kind, applicable to manufactures. Hence all the eminent painters, sculptors, even botanists and florists of Lyons, become eventually associated with the staple trade, and devote to it their happiest conceptions. In the principal school, that of St. Peter's, there are about one hundred and eighty students, every one of whom receives from the town a gratuitous education in art for five years; comprehending delineations in anatomy, botany, architecture, and loom-pattern drawing. A botanical garden is attached to the school. The government allows 3100 francs a-year to the school of Lyons. The school supplies the scholars with every thing but the materials, and allows them to reap the benefit of their works. Their professor of painting is a man of distinguished talent, well known to connoisseurs.

The French manufacturer justly considers that his pattern is the principal element of his success in trade; for the mere handiwork of weaving is a simple affair, with the improved Jacquard loom. He therefore visits the school, and picks out the boy who promises, by taste and invention, to suit his purpose the best. He invites him to his home, boards him, and gives him a small

salary, to be gradually advanced. One gentleman told Dr. Bowring that he had three such youths in his employment; to the youngest of whom he gave 1000 francs, or 40*l.* per annum. After three or four years, if the young artist's success be remarkable, he may have his salary raised to double or treble that sum; and when his reputation is once established, he is sure of the offer of a partnership. Such is the general history of many of the school-boys of Lyons. Even the French weaver, who earns only 15*d.* or 20*d.* a-day, prides himself upon his knowledge of design: he will turn over several hundred patterns in his possession, and descant on their relative merits, seldom erring far in predicting the success of any new style. By this disposition, the minds of the silk-weavers in France become elevated and refined, instead of being stultified in gin-shops, as those of the English too frequently are. In flower patterns, the French designs are remarkably free from incongruities, being copied from nature with scientific precision. They supply taste to the whole world in proportion to the extent of their exportations, which amount to one hundred and ten millions out of one hundred and forty. In the Lyons' school, collections of silk fabrics may be studied, extending over a period of four thousand years, with explanations of the modes in which every pattern was produced, from the rude silks of the Egyptian mummies to the figured webs of the last year.

There are also *weaving-schools*, containing from sixty to eighty scholars. In these a pattern being exhibited, they are required to exercise their invention immediately as to the best means of producing the design on a piece of silk goods. The master re-

moves such difficulties as are occasionally encountered, and leads them on to successful accomplishment of the task.

Within a few years, a large legacy has been left by General Martin, for the purpose of establishing another institution similar to the school of St. Peter.

Their superiority in art is turned to good account in many other French manufactures. Notwithstanding the double price of the raw material in France, their fancy articles in iron and steel are exported in large quantities. Their bronze figures have made their way into all parts of the world, alongside of their silk goods; both being equally productions of fine taste, and therefore yielding profitable returns.

The establishment at Lyons, which takes charge of the interests of its trade, called the "Conseil des Prud'hommes," noticed above, is of a very useful nature. When a manufacturer has invented a new pattern, he deposits a specimen of it, sealed, in the archives of that body, on which he pays from two to ten francs, according to the desired duration of his copy-right. The Conseil can seize all pirated imitation goods, fine the offender, and even imprison him for ten days. There is found to be practically very little difficulty in a man's vindicating his patent-right before this equitable tribunal, which is one of the most popular and best organized institutions of France. It originated in a decree of Bonaparte, in 1806, for the reconstruction throughout the kingdom of the old manufacturing tribunals called the "*maître gardes*." It is composed at Lyons of nine master manufacturers and eight weavers, one of the former being the president; each party being elected by the general votes of its own body respectively,

every weaver who possesses four looms being entitled to vote. This court decides all questions connected with the manufacturing interests of its particular district. Their proceedings are distinguished for temperance and sagacity. The men, who represent the operatives, display sound sense, and join in the discussions of the open court with equal propriety as their employers. All questions between masters and men, between men and apprentices, and, in fact, all which bear in any way on the silk trade, are referred to the Conseil des Prud'hommes. Their disposition seems always to be conciliatory. They examine parties, summon witnesses, with the power of compelling their attendance, and give awards, from which there is no appeal, in reference to any sum less than one hundred francs. The number of appeals from this tribunal is very few.

Throughout the silk district of France the throwing-mills are very small, not many of them turning off more than 1000 pounds weight of organzine per annum, or involving so much capital as 5000*l.* The French manufacturers conceive that they are now behind the English in the economy of this part of the trade, and do not throw so well. Their machinery is certainly very rude compared to what may be seen in our modern Manchester and Derby mills. The average price of throwing organzine, where the throwster is not answerable for loss, is 7 fr. ; of tram, from 4 fr. to 5 fr. (per kilo. ?) Where the throwster is accountable for loss, the price is from 10 to 11 fr. for the former, and from 6 to 7 fr. for the latter. But some is thrown much cheaper, as consisting of coarser filaments ; the organzine being 3½ francs.

In weaving common satin, the average production of a single loom is from three to four ells in a day, of from sixteen to eighteen hours' labour. In consequence of the silk trade of Lyons being one of orders, and not one of stocks, it is extremely fluctuating, the operatives being at one time out of employment, and at another called upon to work twenty hours in a day. The average wages for one style of work, to men and women, is 1*s.* 9*d.* : another average, taken from four hundred to five hundred, gives from 2½ fr. to 4 fr. to a man per day, for shawl weaving. The Lyonnese weaver pays, in taxes on his person, food, and rental, about 54 fr. per annum. He begins his day's labour at from five to six o'clock in the morning, and ends it at eight in the evening. His average expenditure at the *auberge*, for breakfast, dinner, supper, and half a litre of wine, is 30 sous, or 1*s.* 3*d.* ; and if a young man, he spends the surplus of his wages in dress and public amusements. There are about as many women as men employed ; a practice first introduced by Bonaparte's conscription laws, which has continued to the present day.

The principal subject of unpleasant discussion with the manufacturer is the mounting of new patterns, by which the workman suffers from the mania of creating new designs. It is an oppressive burthen to the master of a loom-shop, on whom it altogether falls. The cartoons are furnished by the manufacturer, and the workman stitches them together. The journeyman frequently boards with the master weaver, at the rate of from 45 to 50 francs per month. One quarter of a litre, or half an English pint, of wine is allowed daily to the apprentices by the Conseil des Prud'

hommes. The meals last half-an-hour each, in a day's labour of from sixteen to eighteen hours. In certain common articles, the journeyman (called companion) receives two-thirds of the weaving price, which is so low that not more than one franc and a half is earned daily, for a produce of six ells. Such low goods are, however, generally woven by women and children. The daily expenses of a weaver may be rated as follows :—

Bread, 2 livs., at 4 sous	-	40 centimes.
Meat	- - -	50
Wine, $\frac{1}{4}$ litre	- - -	10 $\frac{1}{2}$
Oil, fire, light	- - -	7 $\frac{1}{2}$
Washing, and other charges	-	10

—  
1 fr. 18 cent.,

or very nearly 1s. 3 $\frac{1}{2}$ d. In consequence of the low wages and great expense of living at Lyons, many of the weavers have lately resumed their original agricultural employments. Three-fourths of the masters and companions are in debt. In case of war, all the younger weavers would betake themselves to arms, and abandon a trade which gives them no prospect of improvement\*.

It appears that there has been a constant depreciation of the wages of silk weaving in France, from the year 1810 down to the present time. The average expense of changing each pattern in a loom is 25 francs, and it falls chiefly on the weaver, rendering him very often the victim of ignorance of the state of trade and of want of taste in the manufacturer. For shawls of great beauty and variety of design, the expense of new mounting may

\* Letters of Falconnet and Charnier, two leading operative weavers of Lyons, to Dr. Bowring, *Committee on Silk Trade*, pp. 556, 557.

amount to 1000 francs, but in such a case it is necessarily defrayed by the manufacturer. When this expense exceeds 100 francs there is generally an understanding between the master and the weaver as to the way in which it is to be paid; and if no specific agreement has been made, it must be settled by the Conseil des Prud'hommes.

#### THE MACHINERY OF THE SILK FILATURE.

##### *Reeling of the Silk from the Cocoons.*

Fig. 1 and 2 represent in plan and longitudinal view the reeling apparatus used in France.

a. The oblong water basin, heated by steam or a stove, commonly divided by transverse partitions, containing sometimes twenty cocoons, five in a group.

b. Hooked wires or eyelets to guide several filaments and keep them asunder.

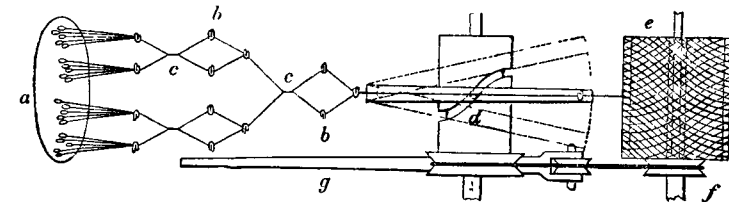

Fig. 45.—Cocoon Filature.—Plan of Reel.

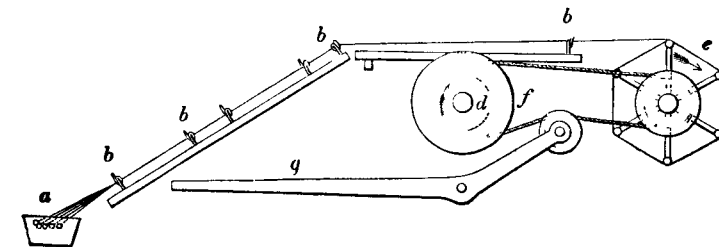

Fig. 46.—Cocoon Filature.—Section of Reel.

*c.* Points where the threads run across each other to clean their surfaces.

*d.* Spiral groove, with a pin to give the traverse motion to the thread, in order to spread it over the reel *e*.

*f.* Pulleys, which transmit by cords the rotatory movement of the cylinder *d* to the reel *e*.

*g.* Friction-lever for tightening or slackening the endless cord, in setting on or stopping the winding operation. There is usually a series of such reels in one apartment driven by one moving power; but each of them, as shown, can be stopped at pleasure.

These filatures are very simple, often domestic, apparatus; but the throwing-mills for doubling and twisting silk are most elaborate constructions. Ever since they were re-modelled by Messrs. Fairbairn and Lillie, upon the cotton-throstle plan, they are incomparably superior in convenience, precision, and speed of performance, to what they formerly were in this country, and still are upon the continent. When these mechanics took the silk-mill in hand, the spindles moved at the rate of only 1200 revolutions per minute: they forthwith raised it to 3000—a velocity since increased to 4500 by Mr. Ritson, a cotton-mill mechanic, in whose favour they resigned this branch of engineering. The representations inserted in the following pages are parts of a complete series of drawings made under my inspection, from the latest and most improved silk-throwing machinery erected by him.

Among the shoals of British aristocracy who migrate to the south every season, surely some might be curious enough to consider the industry of the silkworm, the species of employments to which it gives

rise, and to observe how deeply the lords of the soil of Italy are indebted for their incomes to the growth of silk, and its conversion into organzine in the throwing-mill. What prosperity they may see realized there on a petty scale, by one branch of manufacture, they might see and do profit by at home, though often without acknowledgment, in a hundred more extensive branches. But the point to which they ought peculiarly to direct their attention, is the state of the people engaged in manufactures abroad, compared to their state in their own factory districts; and if they made the comparison with tolerable candour, they would be more careful in future of calumniating the British manufacturers, and of enacting laws for cramping their complicated arrangements. The elegance and comforts of an Italian silk-mill may be judged of from the following description of one by a talented modern traveller.

“There were vast groves of mulberry trees between Verona and Padua; and we visited some of the silk-mills, in which the united strength of men invariably performed those operations which in England are accomplished by steam or water. I saw in a huge horizontal wheel, about a dozen of these poor creatures labouring so hard, that my very heart ached to see them, and I begged that the machine might be stopped that I might speak to them; but when it *was* stopped, and I beheld their half-savage, half-stupified, I had almost said, half-*brutified* countenances, I could not utter a single word—but gave them something and turned away\*.”

The first operation which raw silk undergoes in the

\* Mrs. Jamieson, *Diary of an Ennuyée*, p. 82.



factory, is its transfer from the skeins of the importer, upon bobbins in diagonal lines, so that the ends of the threads may be readily found in case of breakage. The bobbins are wooden cylinders of such thickness as not to injure the filaments by sudden flexure, which smaller cylinders would do, and to be able to receive a considerable length of thread without materially increasing their diameter, and of course their surface velocity in revolving.

Fig. 47 is an end view of one side of a winding-machine, called the *engine*, to show how the motion is communicated to it; the other half, being similar, is omitted. It consists of a long wooden table A, for

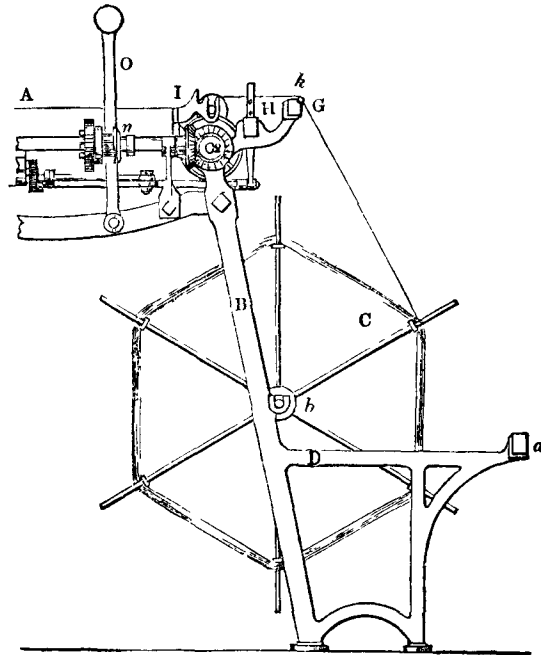

Fig. 47.—Silk-Engine, or Swift.

laying out the skeins upon, supported by strong slanting legs, as at B, on which are the bearings of the light iron reels C. These are called *swifts*, because, though they turn slowly round with the revolving bobbins, yet they do their work quickly compared with hand-winding machines. At every eighth or tenth leg there is a projecting piece D, which carries at its end a horizontal bar of wood a, called the *knee-rail*, for protecting the swifts from the knees of the work-people. The swifts have a stout axis of wood b, traversed by a central iron pin, round which they revolve, in the bearings of the legs B. On the middle of each swift shaft b, is hung a loose ring (not visible in this view), to which a light weight is hung, for communicating friction to the reel, and preventing it from turning round, unless as it is drawn with a gentle force by the thread in its winding upon the bobbin.

The bevel wheel 2 is fixed to the end of the long driving shaft, seen magnified at E (fig. 48), on which are fixed a series of light wheels g (fig. 48), called *stars*, which bear the bobbin-pulleys, and turn them round by friction. To the table A are screwed the light cast-iron slot-bearings I (figs. 47 and 48), for receiving the ends of the horizontal iron spindles, on

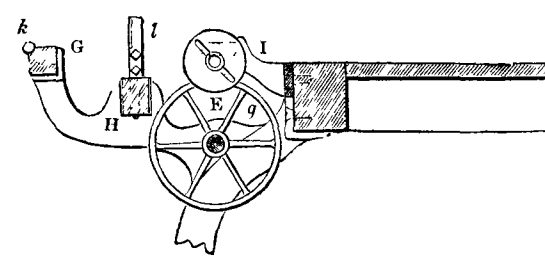

Fig. 48.—Bobbin Mechanism of the Silk Engine.

which the bobbins are mounted for revolving. *G* is a wooden bar seen in cross section, which rests on every tenth or twelfth leg *B* of the engine, and carries on its edge a slender glass rod *k*, over which the silk threads glide smoothly from the swifts to the bobbins. At *H* is the *guide rod*, endued with a lateral or traverse motion, in slots or notches of the arms which carry the bar *G*. On the rod *H* are fitted the guides *l* (fig. 48), which consist of two upright blades of iron, with their edges approximated, so as to form a narrow slit between them adjustable in its width by a screw. This slit-piece is called the cleaner, as it serves to scrape the surface of the threads, to remove any loosely adhering roughnesses, or to stop altogether their winding-on when a knot occurs. The upright lever *O*, with a ball at its top, is the *geering-rod*, which being turned a little one way or other, moves the clutch *n* or locking apparatus, so as to attach the main shaft *E*, and its range of bobbins, to the driving power, or to detach it at pleasure.

2. *Doubling engine.* In the doubling of silk, where two or three threads are wound parallelly together upon one bobbin, an ingenious contrivance is employed to stop the winding-on, whenever one of the threads happens to break. Fig. 49 shows the mechanism in section, and fig. 50 in plan; for one-half of the doubling engine. *A* is one of the end frames, which are connected at their tops by the bar-beam *a*, a plank which extends the whole length of the machine. At *B* are the creels for laying the bobbins *b b*, with their ends in slots. *D* is the end of the horizontal iron shaft which runs through the engine, and carries a series of light wheels *c*, which bear the winding-on bobbins *E*,

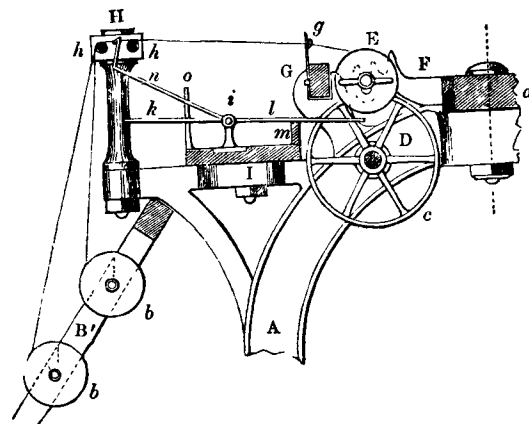

Fig. 49.—Mechanism of Silk Doubling-Mill—Section.

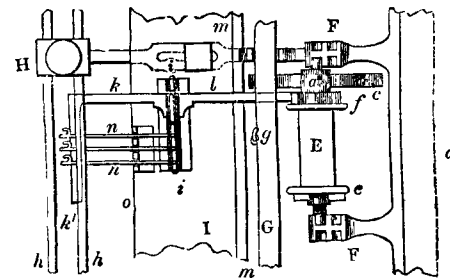

Fig. 50.—Mechanism of Silk Doubling-Mill—Plan.

and turn them by friction at *d*, as in the winding-engine already described. *G* is the guide bar, to which are fixed the cleaner slit-pieces *g*; *h h*, fig. 50, are two polished steel rods, between which the faller eyes *n n* (figs. 49 and 50) work. *I* is the lever board, which bears the lever *k l*, with the fallers *n n*, for stopping the winding-on in case of breakage of a thread. On this board, the light brass props or fulcrums *i i* are fixed, one corresponding to each creel-bobbin. The slight

balance levers  $kl$  swing on a wire axis, which passes through these props; their arms being formed as shown at  $kk'$ , fig. 50. The arm  $l$  is the heavier of the two, and naturally rests on the ridge bar  $m$  of the lever board I.  $nnn$ , are three wires resting at one of their ends on the fulcrum axis  $ii$ , and hanging each at their other hooked end (seen under H in fig. 49) to one of the silk threads, where it passes over the steel rods  $hh$ . These wires are guided in their up and down play with the motions of the thread, by a plate  $o$ , furnished with a vertical slit. Hence, whenever one of the threads chances to break on its way to the winding bobbin E, the wire  $n$ , which was suspended by its hook to that thread between the steel rods in the line of  $hh$  (fig. 49), falls upon the arm  $k$  of the balance-lever  $kl$ , weighs down the arm  $k$ , raises of course the other arm  $l$ , and thrusts its end into one of the three notches of the ratchet wheel  $f$  (seen in its place in fig. 50, and separately in fig. 51). Thus the winding bobbin is held



Fig 51.

fast till the attendant having pieced the ends of the thread, and hung up again the faller wire  $n$ , causes the lever  $l$  to take the horizontal position. If the attendant had meanwhile moved the winding bobbin out of that slot-bearing, which lets its pulley  $d$  rest on the star-wheel  $c$ , into the adjoining slot-bearing, seen in fig. 50, where it remains motionless, she must now restore it to its revolving position.

3. The machine for twisting the single threads of silk either before the doubling, or after the doubling, is called

the *spinning-mill*, sometimes also the *throwing-mill*; though the latter term often includes all the departments of a silk-mill. The section of this apparatus in fig. 52 shows four equal working lines, namely, two on each side of the frame, one tier being over the other. In some spinning-mills there are three tiers,

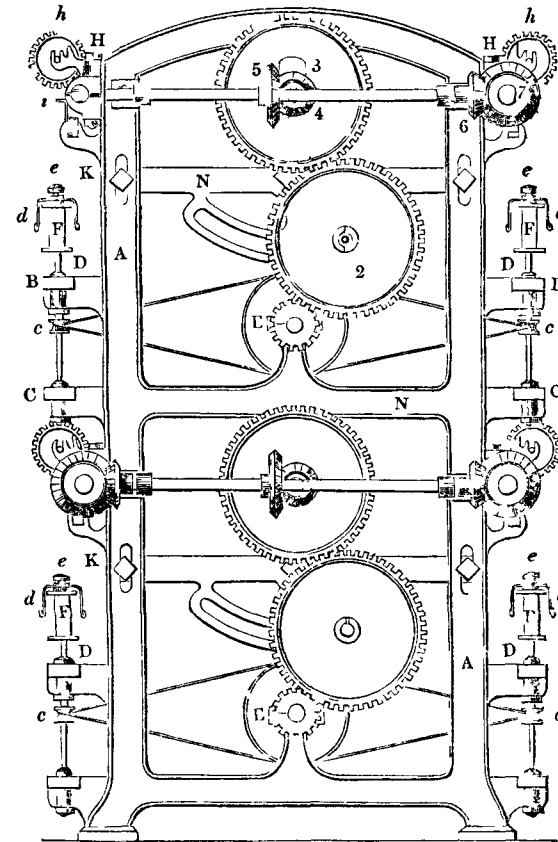

Fig 52 — End view of Fairbairn and Little's improved Silk Spinning-Mill.

but the uppermost is a little troublesome to manage, as it requires the attendant to mount a stool or steps.

A A are the end frames or uprights, bound with cross bars N N ; and two or more similar uprights are placed intermediately between the ends. They are all connected at their sides by beams B and C, which extend through the whole length of the machine. D D are the spindles, having their top bearings fixed in the bar B, and the bottom or step bearings in the bar C. These two bars together are called by workmen the spindle-box : *c c* are the wharves, turned by cords passing from the horizontal tin cylinders E, which lie along the middle of the mill, midway between the ranges of spindles. F F are the bobbins with the doubled silk, which are fixed on the tapering spindles by pressing them down : *d d* are little flyers, or forked arms of wire attached to a disc of wood or washer, which revolves loosely upon the top of the said bobbins F, F, and round the spindles, one of their arms being sometimes bent upwards to serve as a guide to the thread : *e e* are pieces of wood pressed on the top of the spindles, to prevent the flyers from being thrown off : *h h* are the ends of the winding bobbin-shaft, laid in slots near H, as in the former machines. The winding bobbins are driven by toothed wheels, cast on one end of their square iron axes, in the line of *h*, which wheels are turned by toothed wheels on a bar in the line of the bevel wheel 7. On these bobbins, which are of



Figs. 53, 54.—Bobbins of spirally-wound Silk.

considerable diameter, the silk is wound, and distributed diagonally by a peculiar differential mechanism. K K are the guide bars, with the guides *i*, through which the silk passes, being pulled by the winding bobbins on their horizontal shaft in the line of *h*, and delivered by the flyers *d, d*, from their vertical twisting bobbins and spindles F. By the revolution of the tin cylinder E, driven by a steam-pulley fixed on its end, motion is communicated immediately through the cords to the wharves *c*, and their spindles ; and mediately through the plate-wheels 2 and 3, and the bevel-wheels 4, 5, 6, 7, to the rest of the machine. The toothed wheel at E is called the change-pinion ; because, by changing it for another of a smaller or a larger size, the speed of the plate-wheel 2 and 3 may be changed. The axis of the plate-wheel 2 lies in a curvilinear slot, in which it can be shifted to suit the size of the change-wheel put on at E, and to keep it in proper gearing, after which it is fixed by a screw-nut. I regret that the limits of this work will not allow me to make a more extensive use of the fine series of drawings in my possession, illustrative of the exquisite machinery of our modern silk-mills. I trust a fit occasion may, ere long, occur for presenting them to the public.

Silk undergoes certain preparations. The hanks of the raw silk are soaked in tepid soap-water in a tub ; but the bobbins of the spun silk are steamed by inclosing a basket-full of them within a wooden steam-case for about ten minutes. The bobbins are then removed into a cistern of warm water, from which they are taken to the doubling frame.

From 100 to 4000 cards may be required for a pattern in a Jacquard-loom. With one containing

816 cards, the cost of the draft, writing, and stamping, will amount to 10*l.* The annual expense for change of patterns in Jacquard-looms may be about 12*l.* each to the English manufacturer. The total cost of a Jacquard-loom varies from 15*l.* to 30*l.*

It is probable that Mr. Louis Schwabe, and other enterprising silk manufacturers of Manchester, will, ere long, apply the power-loom to the weaving of fancy, as well as plain goods; whereby they will give a great impulsion to the silk trade of England. Messrs. Sharp and Roberts will readily furnish, from their boundless stores of mechanical invention, the requisite machinery for producing any wished-for design, however complicated.

At present, the most skilful weavers of fancy goods at Manchester are natives of Paisley, who combine manual dexterity with moral and intellectual culture. "We had some weavers of silk gauzes who came from Paisley, whom we found very careful at their work, and equal to the French weavers\*."

In silk establishments the machinery can be, and is often employed from three to six hours after the hands have left work, to the advantage of the masters (the number of hours depending on the quality and cost of the silk); therefore the imposing of a restriction on the moving power in silk establishments would have the effect of increasing the cost on the quantity of silk turned off. (Evidence from Congleton.) When water-power is used, the portion of the silk-machinery which contains the swifts (fig. 47), generally works all night without being tended.

\* Committee on Silk Trade.

## BOOK THE THIRD.

---

### CHAPTER I.

#### MORAL ECONOMY OF THE FACTORY SYSTEM.

*Condition of our Factory Operatives, as to Personal Comforts, compared to that of other Labouring Classes; or the Quantity and Quality of their Work considered, relatively to the means of Enjoyment which it can procure.—History of the Discontents, Prejudices, and Legislation on this subject.*

THE ancient feeling of contempt entertained by the country gentlemen towards the burghers, which vented itself during the lawless period of the middle ages, in every form of contumely and outrage, seems still to rankle in the breasts of many members of our aristocracy, is still fostered by the panegyrists of their order, and displayed itself, not equivocally, in the late parliamentary crusade against the factories. One of their most eloquent advocates and partisans speaks of the great development of our mechanical industry in the following scornful terms:—"It is a wen, a fungous excrescence from the body politic; the growth might have been checked, if the consequences had been apprehended in time; but now it has acquired so great a bulk, its nerves have branched so widely, and the vessels of the tumour are so inoculated into some of

the principal veins and arteries of the natural system, that to remove it by absorption is impossible, and excision will be fatal\*.”

Could a metaphor have proved anything, a more appropriate one might have been found, in the process of vegetable and animal generation, to illustrate the great truth, that Providence has assigned to man the glorious function of vastly improving the productions of nature by judicious culture, and of working them up into objects of comfort and elegance with the least possible expenditure of human labour—an undeniable position which forms the basis of our Factory System. While its morbid distemperature is certainly not so great as that of the agricultural system of England, it is much more accessible to control and amelioration. There is one fact which ought to change Mr. Southey's tone of thought about our manufactures: it is, that literature finds in them its principal patron;—the book-trade of Great Britain flourishes and fades with its manufactures in vital sympathy, while it is nearly indifferent to the good or bad state of its agriculture. Which, then, is the moral and intellectual population?

It has, however, been the fate of this *polytechnic*, as of the best philanthropic dispensation ever made to man, to be misrepresented and reviled, not only by strangers ignorant of its intrinsic excellence, but by the very objects of its bounty, the children of its care. When the wandering savage becomes a citizen, he renounces many of his dangerous pleasures in return for tranquillity and protection. He can no longer

\* Southey's Colloquies, vol. i., p. 171.

gratify at his will a revengeful spirit upon his foes, nor seize with violence a neighbour's possessions. In like manner, when the handicraftsman exchanges hard work with fluctuating employment and pay, for continuous labour of a lighter kind with steady wages, he must necessarily renounce his old prerogative of stopping when he pleases, because he would thereby throw the whole establishment into disorder. Of the amount of the injury resulting from the violation of the rules of automatic labour, he can hardly ever be a proper judge; just as mankind at large can never fully estimate the evils consequent upon an infraction of God's moral law. Yet the factory operative, little versant in the great operations of political economy, currency, and trade, and actuated too often by an invidious feeling towards the capitalist who animates his otherwise torpid talents, is easily persuaded by artful demagogues, that his sacrifice of time and skill is beyond the proportion of his recompense, or that fewer hours of industry would be an ample equivalent for his wages. This notion seems to have taken an early and inveterate hold of the factory mind, and to have been rivetted from time to time by the leaders of those secret combinations, so readily formed among a peculiar class of men, concentrated in masses within a narrow range of country.

Instead of repining as they have done at the prosperity of their employers, and concerting odious measures to blast it, they should, on every principle of gratitude and self-interest, have rejoiced at the success resulting from their labours, and by regularity and skill have recommended themselves to monied men desirous of engaging in a profitable concern, and of

procuring qualified hands to conduct it. Thus good workmen would have advanced their condition to that of overlookers, managers, and partners in new mills, and have increased at the same time the demand for their companions' labour in the market. It is only by an undisturbed progression of this kind that the rate of wages can be permanently raised or upheld. Had it not been for the violent collisions and interruptions resulting from erroneous views among the operatives, the factory system would have been developed still more rapidly and beneficially for all concerned than it has been, and would have exhibited still more frequently gratifying examples of skilful workmen becoming opulent proprietors. Every misunderstanding either repels capital altogether, or diverts it from flowing, for a time, in the channels of a trade liable to strikes.

It is therefore deeply to be deplored, for the sake of all parties, as well as for our country's welfare, that the cotton-spinners in particular have been so blinded by prejudice and passion, as never rightly to comprehend the force of this elementary principle. Had their conduct been governed by it, they would have had better wages, and might have appropriated to their own use the whole amount of their earnings, instead of squandering no inconsiderable portion of them upon the fomenters of misrule—the functionaries of their unions. The means which they have all along enjoyed for maintaining themselves and families in comfort have been, generally speaking, better than those possessed in other parts of the kingdom by the average of those artisans who have expensive tools to provide, and tedious apprenticeships to serve; for the net wages of a cotton-spinner have been rarely under 30s.

a week all the year round, nay, sometimes considerably more; constituting an income nearly three times as great as that of the farm-labourer or hand-weaver for as many hours' occupation, and for much severer toil.

The textile manufactures consist of two distinct departments; one carried on by multitudes of small independent machines belonging to the workmen, another carried on by concatenated systems of machinery, the property of the masters. Of the former, muslin and stocking-weaving are examples; of the latter, mule-spinning and power-loom weaving. The workmen of the first class being scattered over a wide tract of country, and being mutual competitors for work and wages, can seldom conspire with one another, and never with effect against their employers. But supposing them to do so in some degree, they would lock up as much of their own capital as of their masters'; that is, they would lose as much interest of money in their unemployed looms and loom-shops, as he would lose on the capital advanced to them in yarn for weaving. The operatives of the latter class are necessarily associated in large bodies, and moreover have no capital sunk in machinery or work-shops. When they choose to strike they can readily join in the blow, and by stopping they suffer merely the loss of wages for the time, while they occasion to their master loss of interest on his sunk capital, his rent, and his taxes, as well as injury to the delicate moving parts of metallic mechanisms by inaction in our humid climate. There are several cotton-mills in Manchester, of which the interest on sunk capital amounts to from 5,000*l.* to 10,000*l.* per annum. If we add to the loss of this

interest, that of the profit fairly resulting from the employment of the said capital, we may be able to appreciate in some measure the vast evils which mischievous cabals among the operatives may inflict on mill-owners, as well as on the commerce of the country.

Philosophers, in every age of the world, have contrasted the supineness of the beneficent principle in man, with the activity of the malevolent; but, satisfied with stating the fact, they left it as a problem for revelation to solve. Proud of the power of malefaction, many of the cotton-spinners, though better paid, as we have shown, than any similar set of artisans in the world, organized the machinery of strikes through all the gradations of their people, *terrifying* or *cajoling* the timid or the passive among them to join their vindictive union. They boasted of possessing a dark tribunal, by the mandates of which they could paralyze every mill whose master did not comply with their wishes, and so bring ruin on the man who had given them profitable employment for many a year. By flattery or intimidation, they levied contributions from their associates in the privileged mills, which they suffered to proceed, in order to furnish spare funds for the maintenance of the idle during the decreed suspension of labour. In this extraordinary state of things, when the inventive head and the sustaining heart of trade were held in bondage by the unruly lower members, a destructive spirit began to display itself among some partisans of the union. Acts of singular atrocity were committed, sometimes with weapons fit only for demons to wield, such as the corrosive oil of vitriol, dashed in the faces of most meri-

torious individuals, with the effect of disfiguring their persons, and burning their eyes out of the sockets with dreadful agony.

The true spirit of turn-outs among the spinners is well described in the following statement made on oath to the Factory Commission, by Mr. George Royle Chappel, a manufacturer of Manchester, who employs 274 hands, and two steam-engines of sixty-four horse power.

“ I have had several turn-outs, and have heard of many more, but never heard of a turn-out for short time. I will relate the circumstances of the last turn-out, which took place on the 16th October, 1830, and continued till the 17th January, 1831. The whole of our spinners, whose average (weekly) wages were 2*l.* 13*s.* 5*d.*, turned out at the instigation, as they told us at the time, of the delegates of the union. They said they had no fault to find with their wages, their work, or their masters, but the union obliged them to turn out. The same week three delegates from the spinners' union waited upon us at our mill, and dictated certain advances in wages, and other regulations, to which, if we would not adhere, they said neither our own spinners nor any other should work for us again! Of course we declined, believing our wages to be ample, and our regulations such as were necessary for the proper conducting of the establishment. The consequences were, they set watches on every avenue to the mill, night and day, to prevent any fresh hands coming into the mill, an object which they effectually attained, by intimidating some, and promising support to others (whom I got into the mill in a caravan), if they would leave their work. Under these circum-



stances I could not work the mill, and advertised it for sale, without any applications, and I also tried in vain to let it. At the end of twenty-three weeks the hands requested to be taken into the mill again on the terms that they had left it, declaring, as they had done at first, that the union alone had forced them to turn out. The names of the delegates that waited on me were, Jonathan Hodgins, Thomas Foster, and Peter Madox, secretary to the union.

“What advance of wages did they require?—Ans. It was considerable, but I don't remember the exact sum; and the regulations required were, *that the men should not be fined for bad work, or for not conforming to the regulations of the mill!*

“Have you ever had turn-outs before?—Ans. Yes, two; in a former turn-out of the spinners, we were waited on by a man named Doherty, and Jonathan Hodgins, two leaders of the union, who, after examining our wage book and the machinery on which the men worked, stated that the wages were fair, and the machinery good; and they ordered them to their work again.”

The increase of the silk trade at Manchester is partly owing to its migration from Macclesfield, which is much depopulated in consequence of the restrictions placed on labour by the unions. Norwich has suffered the same evil. All silk-weavers work by hand; and earn from 12s. to 20s. per week, according to their skill and diligence. Mr. Brocklehurst, being desirous to make gros-de-Naples at Macclesfield, put out 400 or 500 warps, which would have given employment to many more persons; but the weavers would not bring in the webs without an advance on the prices agreed

on, and in fact laid such obstructions in the way, that he was obliged to restrict his business, and produced no goods of consequence in that line, because the men would not work at the Manchester prices. In 1833 about 6,000*l.* were paid weekly in silk-weavers' wages.

Mr. William Harter, in his evidence on the silk trade, says, “I have seen a great many turn-outs, and have invariably found that the result was the lowering of the wages of the operative; that was the result in my own case. In the spring of the year, when the looms were full of goods, the weavers thought they could do what they pleased under such circumstances, and struck for higher wages; but after remaining out of work for three or four months they came to terms. I had meanwhile got hands from the cotton trade\*.”

“I was not aware,” says a Factory Commissioner †, “until I was engaged in the investigation at Glasgow, that the operatives there have so completely organized their association, as not only to prescribe the wages to be paid to the members of the association, but to all other persons, from whatever quarter they may come; that further, no male worker not entered with them *is allowed to work at all*, without their consent, and the concurrence of the association, and never without making a payment to them at the beginning, and continuing a weekly payment at the same rate as their own afterwards; that females, however able, are not allowed to become spinners, or to be engaged as such; and that it is hardly in the power of a piecer, that is of

\* Factory Commission.—Second Rep. of Central Board, D. 2, p. 38.

† James Stuart, Esq., Author of an excellent Tour in the United States.—First Report, A. 1, 126.

an assistant to a spinner, to learn the business of a spinner, unless he is related to a spinner who will bring him forward; that, in short, the object of the Glasgow Association is to make their company a close corporation, accessible only to those whom they choose to admit, and not only to prevent all others from becoming spinners by their regulations, but by a system of intimidation, which they successfully carry into execution absolutely by physical force."

"The mill-owners in Glasgow," says Mr. Graham, "did not attempt to bring down the wages of labour, except when they were higher than in Lancashire, but to get the management of their works into their own hands. Nor did they combine with one another to effect their purpose, as their men had done. The labourer not only says—'I will not work for you, unless for such a price,' but he says—'I will not let any other person do it, however willing;' and he sets a watch upon the streets, that prevents us from getting men in, and will abuse anybody that comes, in the most shocking manner, even to taking their lives, if it were necessary. The consequence is, that we have, once or twice, ourselves attempted to stand out against our men, but we have been obliged to take them in. The practice is illegal, but the law is perfectly inefficient; we never can get a conviction. Within a week before I left Glasgow, they beat a person, and he came back to the work frightened and alarmed, and he was obliged to go out. Some years ago there were several people almost destroyed, by vitriol being thrown upon them by combined men\*."

\* Wm. Graham, Esq., in Committee's Report on Manufactures, p. 335.

When asked, by the Committee, how it happens that he cannot reduce the price of his spinning as low as his neighbours, Mr. Graham answers, "That the combination of spinners in Glasgow will not allow it, and that he cannot admit a new hand into his mill unless he has joined the combination."

What a mortifying predicament, for a most respectable manufacturer to be obliged, by the vindictive spirit of united workmen, to pay from 35s. to 40s. of weekly wages for the same labour which they freely give his neighbour mill-owners for 21s. or 25s.!

It was no wonder that a temper so dictatorial and conspiracies leading to such violence, excited the deepest interest in the public mind, and roused the legislature to enact new laws corresponding to the novelty of the crimes. The conspirators, aware of the horror which they had inspired in every well-principled mind, betook themselves to a bold line of defence. They disavowed the outrages, on the one hand, and denounced their own occupation on the other, as irksome in the highest degree, destructive of all comfort, ruinous to health, and the cause of premature decay of all the faculties of body and mind.

During a disastrous turn-out in Manchester, in 1818, when fifteen thousand of the factory people refused employment for several months, paraded the streets, besieged such cotton-mills as continued to work in defiance of their commands, and threatened to destroy their industrious inmates, the Committee of the Spinners' Union issued the following proclamation,—the fountain-head of the torrents of calumny since so profusely discharged on our factory system:—

“ We believe there is no species of labour so fraught with the want of natural comforts as that the spinners have to contend with ; deprived of fresh air, and subjected to long confinement in the impure atmosphere of crowded rooms, continually inhaling the particles of metallic or vegetable dust, his physical powers become debilitated, his animal strength dwindles away, and few survive the meridian of life, and the grave is often the welcome asylum of his woes. His children! but let us draw a veil over the scene! our streets exhibit their cadaverous and decrepit forms, and any attempt to describe them would be impossible. Let it not be understood that we attach blame to our employers, as applied to these calamities ; they are perhaps inseparable from the very nature of the employment, and our masters may lament, but cannot redress them.”

We shall presently prove that this picture is distorted in every respect, and as to the children in particular, there are no trades in which young persons are engaged in numbers, such as sewing, pin-making, or coal-mining, nearly so salubrious, or so comfortable as a cotton-mill. But let us, meanwhile, pursue for a little the rising tide of defamation.

In consequence of these turmoils and complaints, Sir Robert Peel’s bill for regulating the hours of labour in factories was passed in 1818 : but a similar spirit of discontent continuing to manifest itself, a second bill was passed in 1825, and a third in 1831—the last under the direction of Sir J. C. Hobhouse. A general meeting of the mill-owners and other inhabitants of Manchester took place soon after the passing of the last bill, at which resolutions were made for

enforcing the execution of its provisions, under a committee of superintendence. This bill was soon found to be ineffectual towards protecting children from being worked over-hours under greedy operatives and needy parents : for it held out mutual temptations to collusion and perjury with respect to the ages of the children employed by the spinner to mend his broken yarns, and sweep up the stray fibres of cotton from the floor. As the masters paid the spinners the full allowance of wages for these piecers and scavengers, as they are called, he had a strong motive to prohibit their being worked too long, or beyond their strength, for in all such cases he would suffer loss, by the bad quality of his yarn, and the waste of his cotton.

Every manufacturer is well acquainted with the eagerness of his spinners to earn the highest possible wages by quick work and prolonged hours, and knows that if he stops his mill half an hour sooner than his neighbours, he will certainly lose his most skilful hands. Owners become thus a check on each other, relative both to the time of labour and amount of remuneration. The spinners, being obviously responsible for the quality of the yarn, must of course have the selection and hiring of their juvenile assistants ; yet if they introduce those who are too young, unskilful, or feeble, they would expose themselves to the censure of the overlookers of the rooms, as well as the manager and master of the factory. Hence the tendency of the spinners to overwork children relative to their years, is controlled, directly, by the observation of superintendents, and, indirectly, by inspection of the quality of the work, which, if at all defective, occasions deduction of wages, or even the imposition

of a fine. Nearly the whole of the children of fourteen years of age, and under, who are employed in cotton-mills, belong to the mule-spinning department, and are, in forty-nine cases out of fifty, the immediate servants and dependents, often the offspring or near relations of the spinner, being hired and dismissed at his option. In fact, mule-spinning could not go on with any degree of prosperity if the assistants were independent of the operative. He is therefore their sole patron and master, and as such is naturally courted by poor parents, solicitous to get their children profitably employed. We may judge, from these undoubted facts, of the absurdity and injustice of the clamour so industriously propagated against the proprietors of mills for cruelty to children under their charge. The slightest inquiry on the spot, the most superficial ocular inspection, would have satisfied any candid mind, that the owners, from regard to pecuniary interest, as well as to humanity and reputation, always set their faces against every species of oppression within their premises.

Nothing shows in a clearer point of view the credulity of mankind in general, and of the people of these islands in particular, than the ready faith which was given to the tales of cruelty exercised by proprietors of cotton-mills towards young children. The system of calumny somewhat resembles that brought by the Pagans against the primitive Christians, of enticing children into their meetings in order to murder and devour them. The sentimental fever thus excited by the craft of the Operatives' Union was inflamed into a delirious paroxysm by the partial, distorted, and fictitious evidence conjured up before the Committee

of the House of Commons on factory employment, of which Mr. Sadler was the mover and chairman. It commenced its sittings on the 12th April, 1832, and did not terminate them till the 7th of August following, when it published a mass of defamation against the cotton-mills, spread over upwards of 600 folio pages. Of this notable report, Mr. Tufnell, a most able and candid observer, makes the following remarks in his Factory Commission Report to the Secretary of State:—

“The selection of witnesses to be examined before that body was most extraordinary. Of the eighty-nine who gave evidence, only three came directly from Manchester, though it is the largest manufacturing town in the kingdom, and being almost wholly devoted to the cotton-trade, which is as yet the only business subjected to a factory bill, some important information respecting the experience of former factory bills, and the probable effects of the change it was proposed to make, might reasonably be expected from it. Of these three witnesses not one was a medical man, a manufacturer, or a clergyman. The first was a dresser of yarn, and is now one of the delegates sent by the Lancashire workmen to London to forward the passing of the Ten-Hour Factory Bill, and whose colleague is a man named Doherty, who (it is right that the character of the leaders in this business should be known) originally came to Manchester with a forged character, and was subsequently imprisoned for two years for a gross assault upon a woman; the second is the keeper of a small tavern in the purlieu of the town, and the third is an atheist.

“The first being in London I could not re-examine,

but he refused to corroborate his former evidence before the Central Board of Commissioners when requested to do so by them; to the second, I sent a summons and he refused to attend; the third did attend, and the following is the commencement of his examination:—

“Have you any objection to take an oath? *Ans.* I would rather not. I have no objection to kiss the dirty book. Truth is what I swear by, and wherever I meet her I embrace her.

“Do you believe in a God? *Ans.* Can you tell me what God is? God is incomprehensible. I am a moral character. When I was in London I lived in Mr. Carlile’s shop, Fleet Street. I acted in the capacity of a servant to Mr. Carlile and the Rev. Robert Taylor.’

“Considerable part of this man’s evidence, which fills nine folio pages of the Committee’s (Mr. Sadler’s) Report, refers to charges thirty and forty years old; but every specific accusation which he or his two compeers had made against the cotton-mills, I ascertained, from witnesses of the utmost respectability, to be *absolutely false* \*.”

From this specimen we may judge of the nature of Mr. Sadler’s evidence against the textile factories. Yet so violent was the prejudice raised by its means, as well as by the Chairman’s rhetorical expositions, and those of his parliamentary partisans, that an influential newspaper, responsive to popular feeling, expressed itself on the subject in the following strong terms on the 28th May, 1833:—

\* Supplementary Report of the Central Board of Factory Commissioners, page 209.

“The state of these infants is really, in our eyes, the blackest guilt with which England stands chargeable at the present moment; and we are convinced that the reformed House of Commons will remove it without delay, whatever these Commissioners (on factory employment) may report, whatever new device the hard-hearted manufacturers may have recourse to, and however Ministers may countenance other schemes of procrastination, as they have countenanced this scheme of a commission.” In the same paper appeared an extract from a protest presented to the gentlemen of the Government Factory Commission on their arrival at Leeds. “You appear,” says this modest document, “to be quite ignorant of the subject of inquiry, which to its due examination demands habits, talents, and experience far different from those requisite for mere legal investigations,” &c. &c. &c. In thus reviling the characters and capacities of the Commissioners (who were not all lawyers) Mr. Sadler was singularly out of his reckoning. *Their* examinations and reports are as remarkable for sagacity and candour, as *his* are for the opposite qualities. So gloomily meanwhile did the phantoms of factory cruelty haunt the public mind, that the same talented journal published, on the 18th June, the following remarkable animadversions:—

“The Government and the Commissioners are now on the right way, and we hope will arrive at the end of their journey, with the same humane dispositions, and entitled to the same grateful applause, as at the commencement. It was high time that something should be done, after the publication of the late report from Mr. Sadler’s committee, if not for

the sake of humanity and religion, if not to check barbarous oppression, or to protect helpless infancy, at least to rescue our moral character from disgrace, and our manufacturing system from abhorrence among other nations. We remember a period, when, actuated by a feeling of horror at the atrocities of the slave-trade, some of the more enthusiastic friends of its abolition, in order to terminate the evil, abstained from the use of sugar produced by slave-labour, and if we may credit the sincerity of one of the speakers in the principality of Darmstadt on a late occasion, the people of Germany might, from the strong representations of *our English white slavery*, almost be led to discontinue the use of English manufactures. In a debate which arose in the states of Darmstadt, on a bill for punishing cruelty to animals, Baron Gugern, well known for some political tracts, took occasion to describe the manufacturing system of England, as more cruel than any thing from which it was proposed to protect the inferior creation in Germany. *His picture is not overcharged as limited to our factory population*, though he is wrong in applying its features indiscriminately to our whole population. He seems to imagine that England is one huge factory; that all our children and youths are employed in spinning cotton or weaving calicoes for German consumption, and that there is a perfect contrast, resulting from this labour, between an English and a German village. Now we need not remind our own countrymen, though we may apprise M. Gugern and our German customers, that although a large body of children in our manufacturing towns are subject to the toils and restraints which he so feelingly describes,

the blight has not spread over the whole land; and that our villages are often as happy as those of any nation which wears our broad-cloths or our calicoes."

When Lord Ashley's ten hours' bill came on for discussion in the House of Commons, on July 5, 1833, the Chancellor of the Exchequer, Lord Althorp, said, "that on looking into the provisions of the bill, he could not but feel apprehensive, that if it were passed in its present form, it would have a most injurious effect upon the manufacturing interests of the country. He need not say, that if the effect of legislative interference were to increase the power of foreigners to compete with us, so far from being a benefit to the poor people, whom it was sought to protect, any measure of this kind would be one of the greatest injuries which could be inflicted on the manufacturing population. He said so, because he need only draw their attention to the state of the manufacturing districts to show, that if any measure had the effect of diminishing the demand for our goods, the result would be to throw the whole population of these districts out of work, and in consequence to produce the most miserable effects. He was not one to say that nothing ought to be done in this case, as, from the general excitement and feeling throughout the country, Parliament must interfere, and protect unfortunate children from suffering under such cruel oppression and being treated with undue severity. But when the measure of the noble lord, taking the ages of the parties into consideration, went to fix on the short period of ten hours, he thought he shortened the period too much, as regarded adults, more particularly as all the arguments urged in the house

referred to children of nine, ten, and eleven years old, and did not apply to adults, who had an option to work or not as they thought proper. The house had the opinion of the Factory Commissioners, that the protection heretofore afforded to children was by no means satisfactory; let the house then limit themselves to this subject, without applying themselves to parties for whom their interference was unnecessary, as they could choose for themselves. With this view, should the house agree with him, he would wish to refer the subject to a select committee, and he should suggest, that children, before the fourteenth year of their age, should not be allowed to work more than eight hours a day."

"The great object urged by Lord Ashley," added the Chancellor of the Exchequer, "and one which every man would willingly give his aid to, was to give children the benefit of education, which it was impossible they could enjoy, while compelled to continual labour throughout every day, and he therefore thought that care should be taken that the children should have this advantage during the intervals which occurred in their labour; and that inspections of the mills should take place in order to secure the operation of these provisions of the new bill."

Lord Ashley said, "he had no objection that children under thirteen years of age should work no more than eight hours; neither had he the slightest objection to the system of compulsory education mentioned, for it was a deep source of regret to him that there should be so many thousands in this country deprived of this blessing. It was becoming in Lord Althorp, as a minister of the crown, thus to come forward, and if

he chose to go farther, he should find in him a zealous supporter; and should the noble lord extend his bounty in this way, not merely to factory children, but to all who were destitute, he would not only be the best benefactor to this country, but the most glorious minister that ever existed."

A celebrated Irish member exclaimed, "Then why not legislate at once? On one side was the number of children slaughtered in a year; on the other the possibility of the loss of the sale of a certain portion of calico. The protection ought to last till twenty-one, at all events to eighteen;" assigning as a reason in law, that the Lord Chancellor took especial care of all under twenty-one years, and that the House of Commons was bound to act as universal chancellor.

In the House of Commons, July 18th, Lord Althorp moved an amendment on Lord Ashley's bill, to the effect that protection should be given by the bill only to those who could not protect themselves, and that adults should be left to their own discretion;—a motion which was carried by 238 votes against 93, or with a majority of 145.

It will certainly appear surprising to every dispassionate mind, that ninety-three members of the British House of Commons could be found capable of voting that any class of grown-up artisans should not be suffered to labour more than ten hours a day—an interference with the freedom of the subject which no other legislature in Christendom would have countenanced for a moment. The Gloucestershire manufacturers justly characterized the proposal as "worthy of the darkest ages, when governments took on themselves to control, direct, and punish all handicrafts, trades, and

callings for any diversity in their operations." This, says Mr. Tufnell, is not strongly enough expressed.

We shall now detail a few more particulars concerning the origin of this torrent of falsehood and defamation which lately overflowed the country, and had nearly converted its most productive fields of industry into *sloughs of despond*.

We have seen that the union of operative spinners had, at an early date, denounced their own occupations as being irksome, severe, and unwholesome in an unparalleled degree. Their object in making this misrepresentation was obviously to interest the community in their favour at the period of their lawless strike in the year 1818. Subsequently to this crisis, some individuals of their governing committee made the notable discovery, that if the quantity of yarn annually spun could by any means be reduced, its scarcity in the market would raise its price, and consequently raise the rate of their wages. They accordingly suggested the shortening of the time of labour to ten hours, as the grand remedy for low wages and hard work; though at this time they were receiving at least three times more wages than hand-loom weavers for the same number of hours' employment, and therefore had very little reason to complain of their lot. In fact, it was their high wages which enabled them to maintain a stipendiary committee in affluence, and to pamper themselves into nervous ailments by a diet too rich and exciting for their in-door occupations. Had they plainly promulgated their views and claims, they well knew that no attention would have been paid to them, but they artfully introduced the tales of cruelty and oppression to children,

as resulting from their own protracted labour, and succeeded by this stratagem to gain many well-meaning proselytes to their cause. The clamour for the ten-hour bill, and the subsidiary lamentation for the children, were confined among the operatives, almost exclusively to the mule-spinners. We have here a remarkable proof of the power of passion to stultify the human understanding. Since the said spinners are the sole employers of the younger children in cotton-mills, who are often their own offspring, and entirely at their disposal to hire or to turn away, they were the only persons capable of abusing them, the sole arbiters of their fate, and therefore amenable to the parents and the public for their good treatment. The mill-owner, in fact, could never interfere but beneficially for the children, to protect them against the occasional caprice of these friends to humanity, who alone could exercise tyranny over their dependents. We may judge from these particulars of the effrontery of the Spinner's Union, and of the credulity of their partisans in and out of parliament. If cruelty of any kind existed at any time, the operatives were the only culprits, and ought to have been prosecuted for it, or at least for practising gross imposition on the public to serve their own sinister ends. After receiving so much unmerited sympathy from well-meaning philanthropists, their impudence knew no bounds. Within a week after the factory commissioners arrived at Manchester, the Operatives' Union dramatized the miseries of the children in a public procession. They collected about 4000 of the youngest, mustered them in tawdry array, and paraded them through the streets, heading the motley throng by themselves or their agents, bran-



dishing straps and bludgeons as emblems of their masters' tyranny, but really the instruments of their own wickedness, if punishment were ever inflicted by them with such weapons in their moments of ill-humour.

If it be a maxim of equity in every state that false accusation should recoil on the heads of its authors, what punishment ought to be awarded to those who, after committing unknown severities upon their dependent children, should magnify the extent of the evil a thousand-fold, and lay all this load of exaggerated crime on persons not only entirely innocent and unconscious of its existence, but avowed enemies to its commission in any degree.

The following short extract of evidence given on oath by respectable witnesses will confirm the preceding statement. "Who is it that beats the children?—The spinner." "Not the master?—No; the masters have nothing to do with the children—they don't employ them." "Do you (a spinner) pay and employ your own piecers?—Yes; it is the general rule in Manchester; but our master is very strict over us, that we don't employ them under age." "Are the children ever beaten?—Sometimes they get beat, but not severely; for sometimes they make the stuff to waste, and then correction is needful; but that is unknown to the master—he does not allow beating at all\*."

No master would wish to have any wayward children to work within the walls of his factory, who do not mind their business without beating, and he therefore usually fines or turns away any spinners who are known to maltreat their assistants. Hence, ill-usage

\* Supplementary Factory Commission Report, p. 193.

of any kind is a very rare occurrence. I have visited many factories, both in Manchester and in the surrounding districts, during a period of several months, entering the spinning rooms, unexpectedly, and often alone, at different times of the day, and I never saw a single instance of corporal chastisement inflicted on a child, nor indeed did I ever see children in ill-humour. They seemed to be always cheerful and alert, taking pleasure in the light play of their muscles,—enjoying the mobility natural to their age. The scene of industry, so far from exciting sad emotions in my mind, was always exhilarating. It was delightful to observe the nimbleness with which they pieced the broken ends, as the mule-carriage began to recede from the fixed roller beam, and to see them at leisure, after a few seconds' exercise of their tiny fingers, to amuse themselves in any attitude they chose, till the stretch and winding-on were once more completed. The work of these lively elves seemed to resemble a sport, in which habit gave them a pleasing dexterity. Conscious of their skill, they were delighted to show it off to any stranger. As to exhaustion by the day's work, they evinced no trace of it on emerging from the mill in the evening; for they immediately began to skip about any neighbouring play-ground, and to commence their little amusements with the same alacrity as boys issuing from a school. It is moreover my firm conviction, that if children are not ill-used by bad parents or guardians, but receive in food and raiment the full benefit of what they earn, they would thrive better when employed in our modern factories, than if left at home in apartments too often ill-aired, damp, and cold.

The most curious circumstance in the whole controversy was the different grounds on which the ten-hour bill was advocated by the leaders of the philanthropic crusade, and by the operatives themselves in the factory districts. In London, and the agricultural counties, the Spinners' Union succeeded perfectly in mystifying their dupes by romantic representations of *white slavery*, and of the hecatombs of infants sacrificed annually on the calico-crowned altar of Mammon; but they durst not utter such barefaced falsehoods in Lancashire, because they knew in the first place that they would become laughing-stocks to the other classes of work-people, and in the next, that they would be immediately charged by the superior ranks with either secret cruelty or downright imposture. They would have been told by one and all, "if the children are ill-used, you alone are the criminals." In fact, not a single witness who appeared before Mr. Tufnell to give evidence in favour of the ten-hour bill (and he made it a rule never to turn away any of its advocates, but to summon many of them who would not otherwise have come forward), not one of them, of whatever trade or station he might have been, supported it out of sympathy for the children. That motives of humanity had not the smallest concern in the business, is a fact made out by the clearest demonstration which human testimony can give. We select one or two from a multitude of proofs. "What is the motive with the operatives in general for advocating the ten-hour bill?—They imagine their wages will not be pulled down; that there will be so much less yarn in the market; that the price will rise; and that will

cause their wages to rise. That I am certain is their general opinion.

"Do you think, if they were assured that such a rise of wages would not take place, they would still advocate it?—No; they would never advocate it.

"Has a desire to lessen the labour of young children no influence in making them advocate it?—Not in the least.

"Can you explain why the operatives make this outcry about the cruelty of employing too young children in mills, when in every case of such employment it appears that they are themselves to blame?—As far as I am able to judge, they think that, if the hours of labour were reduced, their income would be the same as at present; that is the notion among our men; many of the spinners with whom I have spoke on it, have told me that.

"Then you think that a desire to decrease the labour of children is not the real reason for advocating the ten-hour bill?—No; I never met one that had that feeling about the children; they all say it would be pleasant to work ten hours, and have the same wages.

"Do you think, that if they thought their wages would be reduced one-sixth (for two hours out of twelve) they would advocate the ten-hour bill?—No; not if they were reduced one shilling."

Nothing can place the folly of the attacks lately made upon the factory system in a stronger light than these documents, which might be multiplied, if necessary. The operatives, blinded by envy, and misled by phantoms of gain, need, in fact, defence against their self-defamation. I am certain that the general accusation of cruelty is groundless in respect even to this

class of individuals. They dare not be cruel, from fear of the just resentment of the very masters whom they falsely charge with cruelty. That particular instances of ill-usage to children do occur sometimes in factories, as in families and schools, is undoubtedly true; and they will happen wherever the depraved nature of man is not renovated by the Christian spirit; but they are exceedingly rare. It would be a gross exaggeration to say they equal in amount, one-tenth of the hardships which children have to endure in pin-manufactories and many agricultural employments.

Since factory labour does not, as we shall fully prove, essentially impair the comfort of those engaged in it, more than other worse paid avocations, we may ask, why should the workmen wish to clog it with legislative restrictions? It is because they reckon, and with justice, that a law compelling their master to turn away all persons under eighteen years of age after ten hours' work will compel him in fact to stop the mill. But as he will then produce a sixth less yarn, he must of necessity raise its price, or cease to spin any more. Now the work-people having usually found that a rise of prices caused a rise of wages in the natural circumstances of increased demand in the market, they therefore concluded that a rise of prices made by the factitious agency of an act of parliament, independently of any increased demand for goods, would have a similar effect on their wages. Here their political economy was grievously at fault. They committed the egregious blunder of confounding a rise resulting from increased demand or competition of purchasers, with a rise resulting from increased difficulty or cost of production. Whereas the two cases

are totally dissimilar: increased consumption would accompany the former condition, and diminished consumption the latter. It would be foolish to devote more time to the refutation of so glaring an absurdity, as that ten hours' work can, in the present state of the world, earn the same wages as twelve hours', the profit on the produce being necessarily reduced in a still greater ratio than that of twelve to ten, on account of the sunk capital being the same as before.

It is certain, then, that the reason which was so prominently put before the public in favour of the ten-hour Bill is altogether groundless—that children in cotton-mills are not injured by their labours, and are not in general overworked. The notion of their being so, is wholly repudiated in the greatest manufacturing district of England. How else can we explain the fact, that persons of the utmost respectability in private life are in the habit of sending their children to work the usual hours in well-regulated cotton-mills? Mr. Rowbotham, for example, the superintendent of nearly 400 workmen in Mr. Birley's mills, a man of equal respectability with any London shopkeeper, has brought up all his children in cotton-factories, and three out of four of them in that department which is usually considered the most unhealthy of all—the card-room. Are we to suppose that Mr. Rowbotham, and hundreds such as he, are so devoid of parental affection as to wish to deform their children, and to subject them to all the miseries described in Mr. Sadler's factory committee; or are they so unobservant, as not to have discovered, if such a discovery can be made, that from eleven to twelve hours' labour in a cotton-mill injures their children? One of two

things must be true; either the tales of the hardships of the factory children are unfounded, or the Lancashire people are utterly devoid of understanding, humanity, and parental tenderness. If those persons who are best acquainted with, and constantly reside in the factory districts, do not rest their advocacy for the ten-hour Bill on the plea of humanity, and if by their conduct they show that they disbelieve this plea, what evidence can outweigh or even balance this argument? It neutralizes, nay, annihilates all other evidence of any kind, that sophistry can adduce. Were it contradicted by all the physicians of London, the physicians must be wrong; if returns of sick societies or mortality tables say otherwise, they must be false—all the testimony that can be raked together from other sources cannot overlay this evidence, without leading to the absurd conclusion, that the whole population of the said districts are void of sense and feeling\*.

It seems established by a body of incontestable evidence, that the wages of our factory work-people, if prudently spent, would enable them to live in a comfortable manner, and decidedly better than formerly, in consequence of the relative diminution in the price of food, fuel, lodgings, and clothing. But the manufacturers fear that, from the lower rate of wages, and the less expensive style of living among the work-people on the Continent, and in the United States, their foreign rivals may, ere long, be able to bring forward many descriptions of cotton goods more cheaply than they can continue to do, if competition advances in the same ratio as it has done for several years. The average of the wages paid to all the persons employed

\* Mr. Tufnell's Factory Commission Report.

in Messrs. Lees's mills at Gorton amounts to 12s. weekly per head, young and old; and as the establishment includes 711 persons from nine years of age and upwards, the wealth diffused by this factory in its neighbourhood must be very considerable. The average of the men's wages in Mr. Ashton's mills at Hyde is 21s. per week, while that of the people not in factory employment is only 14s. The following table of the wages paid in forty-three of the principal mills in Manchester gives irresistible proof to the present proposition.

TABLE

Of the Number of Persons of various Ages, distinguishing Males and Females, employed in forty-three Cotton-Mills, in Manchester, the average clear weekly earnings of each age and sex, the per centage which each age and sex bears to the whole number employed, and the per centage of the total of such age relatively to the gross total employed.

AGES.	Number of Males.	Average clear wages per week.		Per centage of Numbers.	Number of Females.	Average clear wages per week.		Per centage of Numbers.	Number of each age.	Per centage of each age.
		s.	d.			s.	d.			
From 9 to 10	498	2	9½	27	290	2	11½	1½	788	4·58
10 12	819	3	8	4½	538	3	9½	3½	1357	7·87
12 14	1021	5	0½	5½	761	4	10½	4½	1782	10·34
14 16	853	6	5½	4½	797	6	4½	4½	1650	9·57
16 18	708	8	2½	4½	1068	8	0½	6½	1776	10·30
18 21	758	10	4	4½	1582	8	11	9½	2340	13·58
21 & upwards.	3632	22	5½	21	3910	9	6½	22½	7542	43·76
	8289				8946				17235	

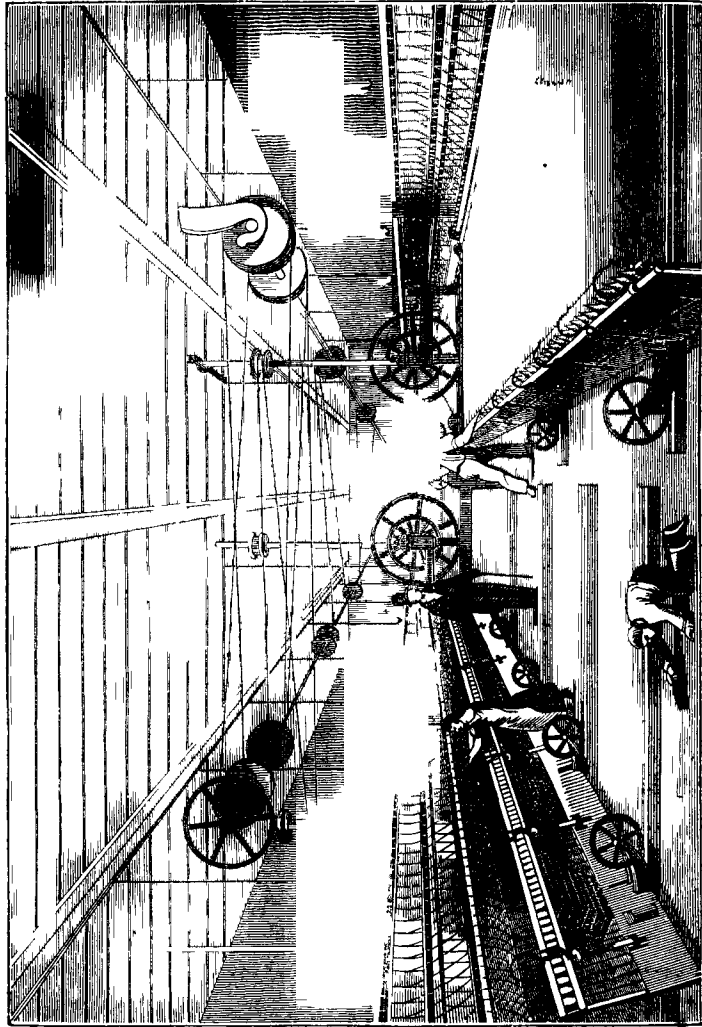

Fig. 55.—Cotton Mule Spinning.

Of all the common prejudices that exist with regard to factory labour, there is none more unfounded than that which ascribes to it excessive tedium and irksomeness above other occupations, owing to its being carried on in conjunction with the "unceasing motion of the steam-engine." In an establishment for spinning or weaving cotton, all the hard work is performed by the steam-engine, which leaves for the attendant no hard labour at all, and literally nothing to do in general; but at intervals to perform some delicate operation, such as joining the threads that break, taking the cops off the spindles, &c. And it is so far from being true that the work in a factory is incessant, because the motion of the steam-engine is incessant, that the fact is, that the labour is not incessant on that very account, because it is performed in conjunction with the steam-engine. Of all manufacturing employments, those are by far the most irksome and incessant in which steam-engines are not employed, as in lace-running and stocking-weaving; and the way to prevent an employment from being incessant, is to introduce a steam-engine into it. These remarks certainly apply more especially to the labour of children in factories. Three-fourths of the children so employed are engaged in piecing at the mules. "When the carriages of these have receded a foot and a half or two feet from the rollers," says Mr. Tufnell, "nothing is to be done, not even attention is required from either spinner or piecer\*." Both † of them stand idle for a

\* Supplementary Report of Factory Commissioners, p. 205.

† The view of mule-spinning inserted at page 211 of Mr. Baines's statistical history of the cotton manufacture, shows how incompetent a general artist is to delineate a system of machinery. He has given pic-

time, and in fine spinning particularly, for three-quarters of a minute, or more. Consequently, if a child remains at this business twelve hours daily, he has nine hours of inaction. And though he attends two mules, he has still six hours of non-exertion. Spinners sometimes dedicate these intervals to the perusal of

torial effect, regardless of truth and propriety. In the first place, he has located the mules in the attic story, and has illuminated them with sky-light windows, in order to show off the cast-iron framing of a factory-roof. Now, mule-spinning requires horizontal light, and is never carried on in the garrets of modern mills. These are reserved for preparation, winding, warping, doubling, web-dressing, &c. Secondly, the piecers are there figured joining the broken threads, when they are five feet distant from the roving ends, and would therefore need to have arms at least six feet long for the purpose. The moment a thread breaks, the one end curls about the drawing-roller at the fixed beam, and the other round the top of the spindle in the carriage; so that in the position of the carriage in that picture, there would be an interval of about five feet between the broken ends. Thirdly, the adult spinner is exhibited as busy with the copping-wire of the mule before him, where he has no business to be; for its carriage is in the act of coming out upon the automatic principle; while he ought to be then standing close by the headstock of the opposite mule, ready to return its carriage by the operation of the one hand and to guide the faller-rod by the other, in winding the yarn of the finished stretch upon the spindles.

In fact, the whole train of operations has been curiously travestied in that engraving. Mule-spinning as there shown off, would be the incessant slavery which Mr. Sadler's partisans described it to be, like the labour of the Danaides, never ending or suspending. Whereas the spinner has nothing to do, while the carriage is slowly drawing and spinning the thread; and the piecers have nothing to do, either during the coming out or going in of the carriage, but they should seize the moment of its proximity to the roller-beam to mend the broken ends, and missing this period, they must remain idle till the completion of another act of stretching and winding on. Were the young persons seen in such positions at such times, they would get a sharp rebuke from the spinner, or more probably be dismissed by him for egregious stupidity. See our view of Mule-spinning, p. 308.

books. The scavengers, who in Mr. Sadler's report have been described as being "constantly in a state of grief, always in terror, and every moment they have to spare stretched all their length upon the floor in a state of perspiration \*," may be observed in cotton-factories idle for *four* minutes at a time, or moving about in a sportive mood, utterly unconscious of the tragical scenes in which they were dramatized.

Occupations which are assisted by steam-engines require for the most part a higher, or at least a steadier species of labour, than those which are not; the exercise of the mind being then partially substituted for that of the muscles, constituting skilled labour, which is always paid more highly than unskilled. On this principle we can readily account for the comparatively high wages which the inmates of a factory, whether children or adults, obtain. Batting cotton by hand for fine spinning seems by far the hardest work in a factory; it is performed wholly by women, without any assistance from the steam-engine, and is somewhat similar in effort to threshing corn; yet it does not bring those who are engaged in it more than *6s. 6d.* weekly, while close by is the stretching-frame, which remunerates its tenters or superintendents, women, and even children fourteen years old, with double wages for far lighter labour. In power-loom weaving also, the wages are good, and the muscular effort is trifling, as those who tend it frequently exercise themselves by following the movement of the lay, and leaning on it with their arms. It is reckoned a very healthy mill-occupation, as is shown by the appearance of the females

\* Report of Mr. Sadler's Factory Committee, p. 325.

engaged in it, in every well-regulated establishment in England and Scotland. (See the engraving at the end of the volume.)

The more refined the labour in factories is, it becomes generally the lighter and the pleasanter. Thus the fine spinning is the least laborious in Manchester, owing to the slowness with which the machinery moves in forming fine threads. The mule for No. 30 or No. 40, makes in general three stretches in a minute; but the mule for higher numbers makes only one stretch in the same time. During at least three-fourths of this minute, the four, five, or more piecers, who attend the pair of mules of 460 spindles each, have absolutely nothing to do, but are seen in an easy attitude, till the carriage begins to start for a new stretch, when they proceed immediately to mend the threads, which break, or are purposely broken on account of some unsightly knot. The piecing is soon over, as the carriage does not stop an instant at the frame, but forthwith resumes its spinning routine, and when it has again come out somewhat less than two feet, it places the rollers and roving beyond the reach of the hands of the piecers, and gives them another interval of repose. There is so little scavenger work required in fine spinning, on account of the small quantity of waste from the long-stapled cotton, that it is usually performed by one of the piecers. From the same cause there is hardly any dust to be seen in the air of the rooms.

The fine-spinning mills at Manchester, which have been so grossly disparaged by the partisans of the ten-hours' Bill, are, in fact, the triumph of art and the glory of England. In the beauty, delicacy, and ingenuity of the machines, they have no parallel among

the works of man; nor in the orderly arrangement, and the value of the products. When 350 hanks are spun, containing only one pound of cotton, they form an almost incredible length of thread, extending 294,000 yards, or 167 miles, and enhancing the price of the material from 3s. 8d. to *twenty-five guineas*. This department of English industry is quite unrivalled, and notwithstanding the most indefatigable efforts of our ingenious neighbours in France, it still lays every foreign weaver of fine muslin and lace under contribution.

It is in spinning the lower numbers, as 40s., and in weaving, that our manufacturers some time ago were most fearful of being hard-pressed by foreign competition. Switzerland has for the last seven years, not only supplied herself, but her neighbours, to a considerable extent with that mean quality which may be reckoned the staple of cotton yarns. It appears that the time of working cotton-mills in Manchester is less, by about one hour daily, than that in any other part of the world, where the cotton manufacture is carried on to any extent; and if the time be further abridged, it would probably prove most injurious to our commerce. Whether foreigners have or have not machinery equal to our own, forms but one part of the question of foreign competition. As the sale of our goods depends in a great measure on the lowness of their prices, the raising of these would cause a serious decrease of consumption—a decrease always much greater than the increased ratio of price. The more remote the market, the more necessary is it to keep the price low, to guard against contingencies, as the goods may otherwise be undersold by the product of the rudest machinery

chester, who resided several years among the best cotton factories of France and Switzerland, says, "that a man there is satisfied with a deal worse clothing, and is more contented at his work than here. The French appeared a very comfortable set of people; they did not get beastly drunk as working men are inclined to do here. Mr. Roberts uses French screws in his manufactory, finding them even at double price cheaper than English ones, owing to their good shape and exact cut; their spiral is more regular, their thread more even, they taper, which is of great consequence, for thus they get tighter in the wood all the way they go. Ours are knocked off so cheap as to be little better than nails\*."

To illustrate the effect which an improvement in machinery produces upon the income and comforts of the operatives, let us take an instance from the spinning department, and it will hold good *mutatis mutandis* in every other.

The spinner is the leading and most important operative in cotton-working. He is the one for whom every preliminary process (called "the preparation," consisting of batting, carding, roving, &c.) is performed. So much weight of prepared cotton is delivered to him, and he has to return by a certain time in lieu of it a given weight of twist or yarn of a certain degree of fineness, and he is paid so much per pound for all that he so returns. If his work is defective in quality, the penalty falls on him; if less in quantity than the minimum fixed for a given time, he

\* Factory Commission Report, Part I, D. I., p. 123.

is dismissed and an abler operative procured. The productive power of his spinning-machine is accurately measured, and the rate of pay for work done with it decreases *with* (though not *as*) the increase of its productive power. Since these machines are in a state of continual improvement, what effect is thereby produced upon the spinners' earnings? The answer to this question will explain the most important cause of the discrepancies exhibited in the column headed "Average net earnings of each individual calculated for sixty-nine hours," and will show whether the ground on which the operatives affirm their wages are continually falling is sound or unsound\*.

The mule-jenny is a *system* of spindles—(see woodcut, page 308.) A spinner manages two of them at the same time. He stands between them; as one is always advancing while the other is retreating, he turns round from one to the other at regular intervals. The one which is advancing draws out the cotton-roving from the range of bobbins at the back, and moves slowly towards the spinner, spinning the thread the while. The greater the number of spindles, the greater is the number of threads, and the higher the productive power of the machine. Mules vary in the number of spindles they bear, from 250 to 1000 each; or for the pair of mules, from 500 to 2000. The spinner has from one to ten juvenile assistants, according to the magnitude of his spinning-machine, whom he engages and pays himself without reference to his master, the mill-proprietor. The number of spindles measures the productive power of the machine, and the masters and men agree upon a scale of prices for labour vary-

\* See my Treatise on the Cotton Manufacture.



ing according to that number. These scales are printed and accessible to all parties. The following is the one at present in force in Manchester :—

The first line will explain all the others. It denotes that a spinner, spinning yarn of the fineness of eighty hanks to the pound, on a mule the productive power of which is represented by 336 spindles, is to be paid at the rate of  $4\frac{1}{2}d.$  the pound of cotton-yarn; that if he spins on a mule bearing 396 spindles and upwards, at the rate of  $4d.$  per pound, and so on; the rate of pay for work done diminishing as the productive power of the machine increases, though not exactly in the same proportion. No. signifies “number of hanks of yarn to the pound.” The figures 336, 348, 396 signify mules carrying respectively those numbers of spindles, and consequently yielding by each effort (technically called the “stretch”) 336, 348, or 396 threads of a given length.

The Manchester List of Prices for Spinning upon Mules of the following sizes, as agreed to by Masters and Men, 5th March, 1831, and in force in June, 1833.

No.	Spindles 336 and under.		Spindles 348 to 384.		Spindles 396 and above.	
	s.	d.	s.	d.	s.	d.
80	0	$4\frac{1}{4}$	0	$4\frac{1}{4}$	0	4
85	0	$4\frac{3}{4}$	0	$4\frac{3}{4}$	0	$4\frac{1}{2}$
90	0	$5\frac{1}{4}$	0	5	0	5
95	0	6	0	$5\frac{1}{2}$	0	$5\frac{1}{2}$
100	0	$6\frac{1}{2}$	0	$6\frac{1}{4}$	0	$6\frac{1}{4}$
105	0	$7\frac{1}{4}$	0	7	0	$6\frac{3}{4}$
110	0	8	0	$7\frac{3}{4}$	0	$7\frac{1}{2}$
115	0	9	0	$8\frac{3}{4}$	0	$8\frac{1}{2}$
120	0	10	0	$9\frac{3}{4}$	0	$9\frac{1}{2}$
125	0	$11\frac{1}{4}$	0	11	0	$10\frac{3}{4}$
130	1	$0\frac{1}{2}$	1	0	0	$11\frac{3}{4}$
135	1	$1\frac{3}{4}$	1	$1\frac{1}{4}$	1	$0\frac{1}{2}$
140	1	3	1	$2\frac{1}{2}$	1	2
145	1	$4\frac{1}{4}$	1	$3\frac{3}{4}$	1	$3\frac{1}{4}$
150	1	$5\frac{1}{2}$	1	5	1	$4\frac{1}{2}$
155	1	$6\frac{3}{4}$	1	$6\frac{1}{4}$	1	$5\frac{3}{4}$
160	1	8	1	$7\frac{1}{2}$	1	7
165	1	10	1	$9\frac{1}{2}$	1	$8\frac{3}{4}$
170	2	0	1	$11\frac{1}{2}$	1	$10\frac{1}{2}$
175	2	$2\frac{1}{2}$	2	$1\frac{3}{4}$	2	$0\frac{3}{4}$
180	2	5	2	4	2	3
185	2	8	2	7	2	6
190	2	11	2	10	2	$8\frac{3}{4}$
195	3	$2\frac{1}{2}$	3	$1\frac{1}{2}$	3	$0\frac{1}{4}$
200	3	6	3	5	3	4
205	3	10	3	9	3	8
210	4	2	4	1	4	0
215	4	7	4	$5\frac{1}{2}$	4	$4\frac{1}{2}$
220	5	0	4	10	4	9
225	5	6	5	4	5	3
230	6	0	5	10	5	9
235	6	$7\frac{1}{2}$	6	5	6	4
240	7	3	7	0	6	11
245	8	$0\frac{1}{2}$	7	9	7	8
250	8	10	8	6	8	5

If this table be considered, it will be seen that the ratio of the diminution in the payment for work done

is less than that of the increase of the productive power of the machine. Hence, the improved machine enables the operative to earn more money in a given time than the imperfect machine. The predominant fear among many operatives is, that improvements in machinery would gradually "drive their wages down to nothing." How unfounded this fear is a little investigation of the above list of prices will show. It is there seen that a spinner spinning yarn of the fineness of eighty hanks to the lb. on a machine of the productive power represented by 336, is paid at the rate of  $4\frac{1}{2}d.$  for every eighty hanks (= 1 lb.) that he turns off, while if he spins on one of the superior power of 396, he is paid only at the rate of  $4d.$  for the same quantity. But the second machine turns off thirty-three pounds of yarn in the same time that the other is employed in turning off only twenty-eight lbs. The ratio of inferior production is therefore as twenty-eight to thirty-three. But twenty-eight lbs. at  $4\frac{1}{2}d.$  the lb. give 126 pence (10s. 6d.) as the earnings made on the first machine during the time in which the operative is enabled to earn on the second 132 pence (11s.). Thus the operative gains  $6d.$ , and the master by this more expensive machine  $1s. 4\frac{1}{2}d.$

It appears that mules for coarse spinning carrying 500 spindles are already introduced with success, and that mules carrying 600 spindles are on the eve of being mounted. By this increase, the productive power of the machine will be augmented one-fifth. When this event happens, the spinner will not be paid at the same rate for work done as he was before; but as that rate will not be diminished in the ratio of one-fifth, the improvement will augment his money earn-

ings for any given number of hours' work. The whole benefit arising from the improvement is divided between the master and the operative. Both the profits of the one, and the earnings of the other are simultaneously increased by it.

The foregoing statement requires a certain modification. Though it is manifest that improvements in machinery of the character just described augment the earnings of the operative, as well as the profits of the capitalist, yet those who dispute the former conclusion will say that a particular case is selected to illustrate the position, and that an important element is omitted in stating it, that the spinner has to pay something for additional juvenile aid out of his additional sixpence. This deduction deserves to be considered and allowed for. The effect of improvements in machinery, not merely in superseding the necessity for the employment of the same quantity of adult labour as before, in order to produce a given result, but in substituting one description of human labour for another—the less skilled for the more skilled, juvenile for adult, female for male—causes a fresh disturbance in the rate of wages. It is said to lower the rate of earnings of adults by displacing a portion of them, and thus rendering their number superabundant as compared with the demand for their labour. It certainly augments the demand for the labour of children, and increases the rate of *their* wages.

If any check were given to the cotton manufacture, nay, if its continual expansion shall not prove sufficiently great to re-absorb those adults whom it is continually casting out, then the improvements in machinery might be said to have a tendency to "lower

wages;" but hitherto these improvements have materially benefited the operatives, not only by enabling a greater number of persons to enjoy the advantage of the enormous rate of earnings attainable in this important branch of human industry than would otherwise have been the case, but they have enabled "an operative" (speaking in general) to earn a greater sum of money at the end of the week than he would have earned had the condition of the machinery remained stationary.

Could we suppose that machinery were suddenly to reach a degree of perfection which dispensed altogether with adult labour, while no greater number of adolescents and children than are at present employed would be required for turning off the quantity of work now executed, it is clear that the adults would be forced to compete with children in the labour-market, and that their earnings would be regulated by those of children.

Fortunately for the state of society in the cotton districts of Great Britain, the improvements in machinery are gradual, or at any rate brought very gradually into general use. Hence the fall in the price of the manufactured article is gradual, and the extension in the demand for it, arising from the decrease of price, bringing it continually within the range of the means of greater numbers of consumers, is likewise gradual, and keeps up the demand for adult labour, and thus counteracts the effect of the improvements of machinery which operate to displace it. Hence no diminution of earnings for adults has thus far arisen.

In the year 1834, in two fine spinning-mills at

Manchester, a spinner could produce sixteen pounds of yarn, of the fineness of two hundred hanks to the pound, from mules of the productive fertility of three hundred to three hundred and twenty-four spindles, working them sixty-nine hours: and the quantity that he turned off in sixty-nine hours more frequently exceeded sixteen pounds than fell short of it. These very mules being in the same year replaced by others of double power, let us analyze the result. The spinner had been accustomed to produce sixteen pounds of No. 200 yarn from mules of the said extent. From the list of prices, it appears, that in the month of May, he was paid 3*s.* 6*d.* per pound; which being multiplied by sixteen, gives 54*s.* for his gross receipts, out of which he had to pay (at the highest) 13*s.* for assistants. This leaves him 41*s.* of net earnings. But soon thereafter his mules have their productive power doubled, being re-mounted with six hundred and forty-eight spindles. He now is paid 2*s.* 5*d.* per pound, instead of 3*s.* 6*d.*—that is, two-thirds of his former wages per pound; but he turns off double weight of work in the same time, namely, thirty-two pounds, instead of sixteen. His gross receipts are therefore 2*s.* 5*d.* multiplied into thirty-two, or 77*s.* 4*d.* He now requires however *five* assistants to help him, to whom, averaging their cost at 5*s.* a-piece per week, he must pay 25*s.*; or, to avoid the possibility of cavil, say 27*s.* Deducting this sum from his gross receipts, he will retain 50*s.* 4*d.* for his net earnings for sixty-nine hours' work, instead of 41*s.*, being an increase of 9*s.* 4*d.* per week. This statement of the spinner's benefit is rather under the

mark than above it, as might be proved by other documents, were it necessary.\*

From the whole body of evidence it may be safely concluded that the earnings of the adults are the largest in mills where the ratio of the number of children to the number of adults is the highest; and that as long as the cotton-working continues to extend, the apprehensions entertained by the operatives, of a fall in wages, either for adults or children, consequent from improvements in machinery, are groundless. The operatives, availing themselves of the single fact of a fall in the wages of spinning per pound, as the productiveness of the mule is increased, continually assert that the spinner has now to turn out double the work for a tenth less wages than in the year 1804. The matter really stands thus: in 1804 a spinner was paid 8*s.* 6*d.* for every pound of yarn of the fineness of two hundred hanks to the pound, spinning on a mule of the average productive power at that time. What that productive power was the operatives do not mention. But we know, that in 1829 a spinner was paid at the rate of 4*s.* 1*d.* for spinning the same quality, on a mule of the productive power of three hundred and twelve; in 1831, and 1833, at the rates of 2*s.* 8½*d.* and 2*s.* 5*d.*, for spinning the same quality on a mule of the productive power of six hundred and forty-eight. These quotations are from the Manchester Price List.

Thus, in 1829 the spinner turned off three hundred and twelve pounds of yarn in the same time that he now takes to turn off six hundred and forty-eight.

\* Supplem. Fact. Report.—Preface to Tables by J. W. Cowell, Esq.

He was paid at the rate of 4*s.* 1*d.* in 1829; he is now paid at the rate of 2*s.* 5*d.* But three hundred and twelve pounds at 4*s.* 1*d.* amount to 1274*s.*; and six hundred and forty-eight pounds at 2*s.* 5*d.*, amount to 1566*s.* He receives therefore 292*s.* more than he did in 1829, for equal times of work. No doubt he turns off “more work, for less wages, than in 1829,” but this is nothing to the purpose, when the proposition to be proved is, that “his weekly wages are lower than formerly.” It is demonstrable to the simplest capacity, that a spinner earns a shilling, a pound, or a hundred pounds, in less time at present than he would have consumed in earning a shilling, a pound, or a hundred pounds, ten years ago, and with the same, or more probably, less labour;—that this enhancement of his earnings has been owing to improvements in machinery;—that the progress of improvement will progressively advance his earnings still higher, and at the same time enable a greater number of individuals to profit by the enhanced rate, than actually profits by the existing rate (provided that nothing occurs to prevent the cotton business from developing itself for the next thirty years as it has done for the last); and that any improvement in the machinery of any one of the numerous departments of cotton-working will operate to enhance the rate of wages in all other branches (as well as in that department in which it takes place), by increasing the actual demand for labour in those other previous branches. Every improvement of cotton machinery, in any department of the trade, has hitherto had the effect of enabling “an operative” (speaking in general of every one in every department whatever) to earn a greater

net amount of money, in any given time, than he would have done had the improvement never taken place.

The misconceptions which the operatives entertain as to the real effect of machinery on the price of labour are the main causes of turn-outs and strikes. They produce rankling discontent towards their masters, and deserve a very full exposure.

It is certainly of great consequence that the operatives themselves should be satisfied that improvements in machinery tend to raise the amount of money that they gain, individually and generally, for the same number of hours' work. This fact is demonstrated by the infallible rules of arithmetic, in actual instances of several average fine spinning-mills; and it is here also proved that the improvements in machinery specified create a fresh demand for young persons, whose wages are augmented in consequence. And as the price of the article in the market will be lowered, from the improved facility of manufacture, more of it will be consumed; hence more hands will be required in the several subsidiary departments, and the wages throughout the whole range of cotton-working will be better than before.

In cotton-spinning it would now be possible to reduce the wages of labour, because, since the mules have been enlarged, there is always a sufficiency of hands; but it has never been the policy of the masters to do so, unless when absolutely compelled by the want of profits, knowing that the lower the work-people are reduced in circumstances, the less dependence can be placed upon their attention. The operative spinners, aware that a great excess of hands would have the effect of reducing their wages, combine to

pay the expenses of sending their unemployed comrades away to America. Mr. H. Houldsworth, of Glasgow, states that he knows this fact from the individuals themselves, and from their wives, and has occasionally been solicited to aid the families in their emigration, and to forward to them sums contributed by the union for their temporary support. "Within the last three years there have been not less than eighty or one hundred spinners shipped from Glasgow, which is perhaps one-eighth of the whole\*." The trade-unions are, in fact, bound by their articles to pay certain sums to their idle members, in order to support them, and to prevent them volunteering to work at under-wages from necessity. The weekly allowance of the union, joined to the fear of incurring its displeasure, takes away this temptation. The cost of transporting a spinner across the Atlantic varies from 15*l.* to 20*l.*

"When I went to Glasgow, in the year 1799, the spinners did not eat animal food above once in the week: they consume now, at least four times the quantity they did then †." Their diet was, in the first years of this century, herrings, oatmeal, and potatoes. At that period the spinning was extremely limited: the hands were principally Highlanders, of lazy, listless habits, who could not be persuaded to earn above 12*s.* or 14*s.* a week, choosing rather to live upon oatmeal and potatoes, till they were stimulated by the example of some Englishmen, brought from Manchester by Mr. Houldsworth, to set them a pattern of active industry. They worked at that time from six

\* Report on Manufactures, p. 311, H. Houldsworth, Esq.

† Ibid. p. 314, ditto.

in the morning till half-past eight in the evening, but produced far less work than is done now in much fewer hours from improvements in machinery and manipulation. But still the Glasgow-mills are, in productive power, much in arrear of the Manchester ones, as is proved by the circumstance of thirty or forty per cent. more being paid for the same produce of yarn in the former than in the latter place\*. The Scotch manufacturers have been since endeavouring to raise the standard of their machinery to that of the English, and have made in many cases considerable approximations.

Under what pretext, or with what face of pretension, operatives, whose labour is assisted by steam or water power, can lay claim to a peculiar privilege of exemption from more than ten hours' daily labour it is hard to conjecture. They compare their toil with that of the small class, comparatively speaking, of artisans, such as carpenters, bricklayers, stone-masons, &c., who, they say, work only from six to six, with two one-hour intervals for meals: a class, however, in this material respect distinguished from most factory operatives, that their work is done entirely by muscular effort, and after serving a long apprenticeship with no little outlay. But what do the factory people think of the numerous class of domestic operatives, the stocking or frame-work knitters, the hand-loom weavers, the wool-combers, the lace-manufacturers, and a variety of others, who work, and very hardly too, from twelve to sixteen hours a-day, to earn a bare subsistence; and this frequently from a very early age, and in a state of confinement irksome to the mind

\* H. Houldsworth, Esq., Committee on Manufactures, p. 318.

and injurious to the body? The consideration is also overlooked by these interested reasoners, that by reducing the hours of labour, and thereby the amount of subsistence derivable from the less objectionable occupations, they would cause a corresponding increase of competition for employment in the more objectionable ones, and thus inflict an injury on the whole labouring community, by wantonly renouncing the fair advantages of their own.

On the principles expounded above, the woollen manufacturers in the large mills pay much better wages to their workmen than the domestic manufacturers do to theirs\*.

The factory system, then, instead of being detrimental to the comfort of the labouring population, is its grand palladium; for the more complicated and extensive the machinery required for any manufacture, the less risk is there of its agents being injured by the competition of foreign manufactures, and the greater inducement and ability has the mill-owner to keep up the wages of his work-people. The main reason why they are so high is, that they form a small part of the value of the manufactured article, so that if reduced too low by a sordid master, they would render his operatives less careful, and thereby injure the quality of their work more than could be compensated by his saving in wages. The less proportion wages bear to the value of the goods, the higher, generally speaking, is the recompense of labour. The prudent master of a fine spinning-mill is most reluctant to tamper with the earnings of his spinners, and never consents to reduce them till absolutely forced to it by a want

\* Mr. John Brooke, in Committee on Manufactures.

of remuneration for the capital and skill embarked in his business.

When a well-managed spinning and weaving factory are associated in one concern, the train of operations and adjustments becomes more elaborate, the difficulty of competition, from the augmented capital and skill, is increased, while the profits in consequence become higher, or at least more secure. The complication in the present case is greater than many suppose, and merits particular notice. The cotton must be selected, in price and staple, to suit the intended fabric, or market of sale. It must be willowed, batted, mixed, carded, drawn with suitable doublings, roved, and stretched, in an appropriate manner, by machines differing in structure and adjustment for different qualities of goods. It must be spun into warp-yarn and weft-yarn, each of peculiar grist; and these yarns must be dressed and woven on a particular power-loom, adjusted both to the yarns and to the style of goods required. If any one member in this long train of operations proves defective, the profit in the product may be much impaired, or become altogether nugatory. The preceding processes are all mechanical, continuous, and mutually dependent. Were they partly mechanical, partly chemical, and also discontinuous, there would be a risk of confusion from the multiplicity of operations in one factory, and the work, as in the printing of calicoes, would in most cases be more profitably conducted by a separation of the mechanical and chemical arts into two distinct establishments.

The power-loom factories now generally weave only their own yarn, spun to suit their peculiar

fabric; and hence they generally command a better profit on their capital than establishments in which the same capital is expended in either the mere spinning of power-loom yarn, or the weaving of what is purchased.

The throstle, on which warp is usually spun, may be considered to be a complete automaton, capable, on good construction, of furnishing a very uniform yarn; but the mule, on which weft is always spun, has been, till recently, only half automatic, and has partaken, therefore, in a certain degree, of the irregularities of hand-work, varying with the skill and steadiness of the workman. The improved self-actors of Messrs. Sharp, Roberts, and Smith, are likely to remove the above cause of irregularity in calico and fustian wefts, and therefore they place a weaving factory which works in train with them, in a condition to produce fabrics of invariable excellence. This new mechanical union of automatic spinning and weaving promises to have two admirable results. It will, in the first place, put an end, in this large department of factory labour, to the folly of trades' unions, so ruinous to the men, and so vexatious to the masters; and in the second place, it will secure, for a long period to come, the monopoly of coarse cotton fabrics to Great Britain. The continental nations must serve a severe and tedious apprenticeship under the fostering care of tranquillity and capital, before they can fabricate and manage a good system of throstles, self-actors, mules, and power-looms, like those now in vigorous exercise in Stockport. As to the United States, it may be presumed that the Southern part of the Union will prefer getting cheap goods from their great customer,

England, in exchange for their agricultural produce, to buying dearer goods from their illiberal brethren in the North-east.

This combination of spinning and weaving in one establishment has lately given a fresh impulsion to our cotton trade, and is likely to render it paramount over all competition; enabling it to furnish supplies of cheap clothing to many millions of new customers in every region of the globe. New factories will hence arise, requiring multitudes of new hands, presenting prizes in the lottery of life to the skilful and steady operatives, and enabling them to become managers or masters.

On the other hand, non-factory processes of art which can be condensed into a single frame or machine moveable by hand, come within the reach of operatives in every adjacent country, and will have their profits ere long reduced to the *minimum* consistent with the employment of capital in it, and their wages brought down to the scale of those in the cheapest or meanest living country. The stocking trade affords a painful illustration of this fact. No manufacturer in this country can afford to make stockings, unless he can get labour at as low a rate as in Germany; because a German stockinger may easily have as good a stocking-frame, and work it as well, as an English frame-knitter. In the market of the world, therefore, Great Britain has here no advantage by its machinery and capital over other countries, where the materials of the fabrics can be purchased at nearly the same price. The same reasoning may be applied to the bobbin-net trade, in so far as it is carried on by hand-machines. The wages now paid for this most ingenious fabric

are deplorably low, in consequence of the competition of the continental handicraftsmen, who are content to live in the poorest manner. Thus also the profit on lace made by power-machines has been reduced, for a time at least, even below its natural level, in consequence of the possessors of hand-machines continuing to work them, in the vain hope of redeeming their first great cost in some degree, though the wages of their labour meanwhile can hardly keep them alive.

It deserves to be remarked, moreover, that hand-working is more or less discontinuous from the caprice of the operative, and never gives an average weekly or annual product at all comparable to that of a like machine equably driven by power. For this reason hand-weavers very seldom turn off in a week much more than one-half of what their loom could produce if kept continuously in action for twelve or fourteen hours a day, at the rate which the weaver in his working paroxysms impels it.

A gentleman in Manchester, one of the greatest warehousemen in the world, told me that 1800 weavers, whom he employed in the surrounding districts, seldom brought him in more than 2000 pieces per week, but he knew that they could fabricate 9000, if they bestowed steady labour on their looms. One young woman in his employment, not long ago, produced by her own industry upon a hand-loom six pieces a week; for each of which she received 6s. 3d. This fact strongly confirms what Mr. Strutt told me concerning the discontinuous industry of handicraft people. Learning that the inhabitants of a village a few miles from Belper, occupied chiefly by stocking weavers, was in a distressed state from the deprecia-



tion of their wages, he invited a number of the most necessitous families to participate in the better wages and steadier employment of their great spinning-mills. Accordingly they came with troops of children, and were delighted to get installed into such comfortable quarters. After a few weeks, however, their irregular habits of work began to break out, proving both to their own conviction, and that of their patrons, their unfitness for power-going punctuality. They then renounced all further endeavours at learning the new business, and returned to their listless independence.

Let any curious observer pay occasional visits to the workshops of stocking or lace weavers, and he will seldom find the men to be steadily occupied with their labour, even during the hours fixed on by themselves.

In hand-weaving, however, the depreciation of wages has been extraordinary. Annexed are the prices paid at different periods in Manchester for weaving a sixty reed  $\frac{3}{4}$  cambric, as taken in the month of March each year; the weaver paying threepence out of each shilling for winding his warp, for brushes, paste, &c.

In 1795, 39s. 9d. In 1810, 15s. In 1830, 5s.  
1800, 25s. 1820, 8s.

The following painful statements made to the Factory Commissioners will show in how abject a condition are our so-called independent handicraft labourers, compared with that of those much-lamented labourers who tend the power-driven machines of a factory. The former class needs all the sympathy which Mr. Sadler's faction so perniciously expended upon the latter.

The present net weekly earnings of the cotton hands in the stocking trade are from 4s. to 7s. a week; but those received by a far greater number are less than

the lowest sum. The consequences are truly deplorable. The workmen are physically deteriorated, mentally depressed, and too often morally debased\*. Ill-fed, ill-lodged, and ill-clothed, with care-worn and anxious countenances, they constitute a peculiar class of misery. It is supposed that the hosier's profits have decreased in at least an equal proportion with the decrease of wages. A number of instances are adduced by Mr. Felkin as fair specimens of the situation of the plain full-wrought cotton-hose workmen in March, 1833. They are taken indiscriminately from a very large population similarly employed; but all of them are sober and industrious persons. They fully justify the public appeal made at a meeting of frame-work knitters in September, 1832, "that their average earnings are not more than 6s. 6d. a week." On this sum, a man, his wife, and children, have to be maintained. Many among them are therefore extremely wretched and destitute of the necessaries of life; some have neither blanket nor sheet, and sleep in a little straw. The embroidery of bobbin-net, called lace-running, also a non-factory household work, painfully illustrates our position. No less than one hundred and fifty thousand females, chiefly of very youthful ages, get their livelihood from this employment in Great Britain. The work is wholly domestic; and though requiring more skill and harder labour than any other branch of the lace business, it is the worst paid. "Almost the youngest of them," says Mr. Power (and they begin at the age of nine or ten), "is able to speak with regret of a better state of earnings and a period of less necessity for constant labour.

\* Felkin: Factory Commission Report.

They begin early, and work late, and during this long daily period their bodies are constantly bent over the frame upon which the lace is extended, the head being usually kept within five or six inches of the frame, the edge of which presses against the lower part of the chest. One effect universally produced by this habit is short-sightedness, and often general weakness of the eyes; with consumptive tendency, distortion of the limbs, and general debility from the confinement and the posture\*.”

Aversion to the control and continuity of factory labour, and the pride of spurious gentility, or affectation of lady-rank, are among the reasons why young women so frequently sacrifice their comfort and health to lace-embroidery at home. One girl in her examination states, “I like it better than the factory, though we can't get so much. We have our liberty at home, and get our meals comfortable, such as they are†.”

In thus exposing some of the evils incident to rustic and handicraft labour, while I desire to lead the benevolent to devise means for their mitigation, I wish at the same time to remove that unjustifiable prejudice which hinders both of these classes from participating in the better paid and more comfortable factory employments. There are many trades of great extent against which no public odium has been stirred up, which are, however, far more noxious to health and morals than a cotton-mill. Mr. Tufnell, after examining several witnesses in regard to the condition of the boys and girls employed in the Worsley coal-mines,

\* Report by Mr. Power, on Nottingham, p. 17.

† Factory Commission, Nottingham, p. 20.

near Manchester, descended into them to verify the truth of the statements.

“This mine,” says he, “was very damp, and great part of it wet under foot; the roof in many places was dripping, which was also the case throughout a great portion of the canal, during my passage along it. As this was said to be the best mine in the place, I cannot much err in coming to the conclusion, both from what I saw, and the evidence of the witnesses given on oath above, that it must appear to every impartial judge of the two occupations, that the hardest labour, in the worst room, in the worst conducted factory, is less hard, less cruel, and less demoralizing, than the labour in the best of coal mines\*.” A brutality of manners is here disclosed, too gross for transcription, and most discreditable to the masters of the mines.

In Sir David Barry's able report from Glasgow, the state of the non-factory weavers is depicted in the following cases:—

“John Harrup works in a back damp earthen-floored shop, and sleeps in a miserable dirty garret in the same building; no bedstead, scarcely any furniture. Earns on an average 6s. per week, out of which he pays all his loom expenses, more than 1s. per week. He is twenty-five years of age; his wife twenty-one; one child; likely soon to have another. He is thin, pale, hollow-cheeked, and looks half-starved. He works from five in the morning till nine at night now (sixteen hours), and often longer in winter. Solemnly assures me that he never takes thirty minutes to all his meals, during working hours. Would like

\* Factory Commission, Tufnell, p. 82.

exceedingly to become a power-loom dresser, but it requires great interest to get such a birth."

"William Britton is now weaving a web of twenty-three hundred fine, at the rate of  $6\frac{1}{4}d.$  per forty-five inches in length. Mr. Rodger, of Mr. Monteith's works, now present, states that he has paid, within the last twenty years, 3s. for the same work."

"Thomas Smith. Two elder daughters, now weaving, would go to power-looms if they could get places\*."

After detailing several such sad cases, Sir David makes the following observations:—

"It is, I conceive, unnecessary to specify the miserable domestic circumstances of each hand-loom weaver's family which I have visited. They are all reduced to the most squalid poverty; compelled by competition to sell their labour so cheaply, that the very utmost quantity which an individual can furnish is barely sufficient to procure for him in exchange the coarsest raiment, the meanest dwelling, and but a stinted allowance of the cheapest food. There is no combination among these poor men. They work in damp detached cellars as long as they can see. Each brings his individual labour to the proprietor of the material, who will of course accept the cheapest offer.

Not so the spinners and power-loom dressers, who have been all hand-loom weavers, but now prevent any more of their former companions from being employed in their present business. They are united into close exclusive societies, and absolutely possess a monopoly of well-paid cotton labour. They keep up their

\* Factory Commission Report, part 2. Glasgow, p. 42.

prices and keep down their numbers. They can stop every factory in Glasgow whenever they please, and their means would enable them to hold out some time; but a strike of a month would starve more than three-fourths of the hand-loom weavers, even supposing that they could bring about a strike, which under their circumstances would be impracticable. The occupation of draw-boys and girls to harness-loom weavers, in their own shops, is by far the lowest and least sought after of any connected with the manufacture of cotton. They are poor, neglected, ragged, dirty children. They are seldom taught any thing, and they work as long as the weavers, that is as long as they can see; standing on the same spot, always barefooted, on an earthen, cold, damp floor, in a close damp cellar, for thirteen or fourteen hours a day. They earn 2s. per week, and eat porridge, if their parents can afford it; if not, potatoes and salt."

The steam-engine is, in fact, the controller-general and main-spring of British industry, which urges it onwards at a steady rate, and never suffers it to lag or loiter, till its appointed task be done. It also relieves that irksomeness of exertion, before which the diligence of the handicraftsman is seen to give way.

We have already stated that the labour is not incessant in a power-driven factory, just because it is performed in partnership with the workman's never failing friend, the steam-engine. Those factory employments have been shown to be by far the most irksome and exhausting which dispense with power; so that the way to put the workman comparatively at his ease, is to enlist a steam-engine in his service. Compare the labour of an iron-turner at one of the

self-acting lathes so common now in Manchester, and another at one driven by a power-strap as in London, where, however, the cutting-tools are held in the hands and regulated by the power of the arms and dexterity of the fingers. In the former case, the mechanism being once adjusted leaves the workman absolutely nothing to do but look on and study the principles of his trade, as the engine will finish its job in a masterly manner, and immediately thereafter come to repose by throwing itself out of gear. From the preceding details, the world may judge of the untruth and even absurdity of much of the pretended evidence scraped together and bespattered on the factories. In the famous report of Mr. Sadler's committee, we find Mr. Longston of Stockport saying, that "double the labour and attendance is now requisite that was formerly needed, so that though there may be a great improvement in machinery, there is at the same time a great increase in actual labour, or the labour has increased in intensity since he was a boy in 1810!"

No statement could better illustrate the power of prejudice to pervert the judgment, and to lead it to a conclusion the reverse of the truth, than the foregoing. The whole structure of the cotton-factories, from the impelling main-wheels and shafts down to the smallest pivots of the spindles and bobbins, has been regularly advancing on the automatic principle in accuracy and facility of performance, with a corresponding diminution in the toil and irksomeness of superintendence. In fact, there is no department of the spinning or weaving processes which calls for nearly the same solicitude in the workman's mind, and the same labour

of his arms, as were requisite to earn the same wages twenty years ago. The number of spindles in the mules has been of late years, no doubt, greatly increased as well as the speed of their revolution, but there has been a proportional decrease in their friction, with increased facility and certainty of their work. The effect has been, as I have shown, to raise rather than to lower the weekly wages of the workman, in consequence of the improved productiveness of his machine in quantity and quality of yarn. Mules made prior to 1822 seldom carried on an average more than 220 spindles each; those made since 1831, carry 400 and upwards for spinning the coarser numbers of yarn, and from 700 to 1000 for the finer. The labour for spinning a pound weight of cotton into yarn of forty hanks per lb., cost in 1812, 1*s.*; and in 1830, it cost 7½*d.* In 1812, each spindle turned off two hanks daily; in 1830, two hanks and three-quarters; whereas, to produce the same amount of wages per lb. at the two periods, it should have turned off, at the latter, three lbs. and one-fifth. We have here an apparent deficiency of  $\frac{2}{5}$  or nearly  $\frac{1}{3}$  deducted from 3½; but this deficiency is more than made up by the increased number of spindles—nearly double, which one spinner can manage on the improved mule. At present a good mule will turn off daily upwards of three hanks per spindle of the above number, so that all its new spindles bring extra wages.

Mr. Tufnell, the commissioner, in his masterly report on the factories, after acknowledging his former prejudices against factory labour, records the conviction which his elaborate survey had wrought on his mind in the following strong language:—

“It is my firm belief, that there is not a better or more certain mode of benefiting a country village than by establishing a cotton-factory in it.” I entirely coincide in this opinion, and shall enforce it by a few specific illustrations.

It has been justly remarked by one of the first manufacturers in the kingdom, that in large towns, and particularly with so mixed and fluctuating a population as that contained within the precincts of Manchester, with its various occupations, its hastily and imperfectly constructed streets and crowded dwellings, and its many incentives to vice—it is no easy task to determine the effect of each particular employment. The pure unmixed effect of factory labour will be best and most easily found in the country—where it affords regular employment during a series of years to the same families—yet even in Manchester evidence enough to satisfy the candid inquirer may be obtained by inspecting the factories and the dwellings of the working classes. It may be shown that the children of orderly parents, of both sexes, are taught at home and in schools; and that though there are too many heads of families who wholly neglect or set a bad example to their children, still, in Manchester, and in all other large towns, the attendance at the Sunday schools of such as are employed in factories, shows that that class of the operatives furnishes its full proportion of scholars.

Sir David Barry, after completing his medical survey of the factories, writes, “I must state to the Central Board, and I trust that it will reach his Majesty’s government, that no case of cruelty, gross oppression, or of punishment attended with corporal injury, in-

flicted by owners of mills upon their workers, has come to my knowledge during my investigations as a Factory Commissioner in Scotland; whilst on the contrary, many traits of almost parental kindness on the part of the masters, and of corresponding gratitude on the part of the servants, have been brought before me in the course of my inquiries\*.”

I shall now adduce a few examples of the influence of rightly regulated cotton-mills on the well-being of their inmates, derived from my own observations. One of the original emporiums of the cotton manufacture is the establishment of the Messrs. Strutt, situated in the fine valley of the Derwent, a few miles below Cromford, the primitive seat of the water-spinning-frames. The cotton-factories of this eminent family have for half a century furnished steady employment and comfortable subsistence to a population of many thousand individuals. During this long period, the skill, prudence, and capital of the proprietors have maintained their business in a state of progressive improvement, and nearly exempt from those fluctuations which have so often, in that interval, spread seasons of distress among agricultural labourers. So high is the character of their stocking-yarns and threads for uniform excellence, that the stamp of their firm on the great bale is a passport to their ready sale without examination in every market of the world. Under their auspices the handsome town of Belper has arisen, built of hewn stone, with streets flagged with the same, in regular houses on the most commodious plans, where the operatives with their families pass the tranquil tenour of their lives. The mills there, plainly

\* Second Report of Factory Commissioners, p. 1, note.

elegant, built also of stone, as well as their other mills at Millford, three miles lower down the river, are driven altogether by eighteen magnificent water-wheels, possessing the power of 600 horses. A self-acting governor attached to each wheel adjusts its velocity to the purposes of the factory, and is never in a state of repose, but is seen incessantly tightening or slackening the reins of the mill-geering, so to speak, according to the number of machines moving within, and the force of the stream acting without. As no steam-engines are employed, this manufacturing village has quite the picturesque air of an Italian scene, with its river, overhanging woods, and distant range of hills. A neat refectory is fitted up within the works, where any of the work-people, who choose, may have a comfortable pint of hot tea or coffee, including sugar and milk, for one halfpenny. The persons who regularly join in this refreshment, become entitled to medical attendance gratis. A dancing-room for the recreation of the young is also provided.

Several years ago a number of the operatives formed themselves into a society on the co-operative plan, for laying in their provisions and materials of clothing in the wholesale market, in order to benefit by the profits which usually go to the retailer. As the society wore a beneficial aspect it received the concurrence of the proprietors, and was countenanced by one of them becoming a member of the managing committee. For some years the scheme seemed to work well; the goods were bought for ready money, and ostensibly at the lowest current price, and they were distributed to the members in proper proportions, according to their wishes or their means. The money profits, or balance of the

savings at the end of the year, were divided among them, and amounted frequently to as much as well nigh paid their house-rents. Eventually certain evils began to be developed, which were not at first sight foreseen. Travelling dealers, who came in quest of orders for goods, found out that a bonus might be given with advantage to an influential secretary or treasurer, and might secure a preference in the sale of indifferent articles, such as tea or cloth, at a price above their ready-money value. Disputes and suspicions began to arise. The committee, though chosen freely by the whole body of the associated work-people, were naturally selected from the more prominent among them, such as the mill-overlookers, and were therefore often continued from year to year, whereby some of them had opportunities of becoming adepts in studying their own interests more than those of the society at large. In fact, driving bargains for the society or themselves, began to occupy their thoughts too much to the exclusion of their proper mill duties. The main evil attendant on this plausible plan was its depriving the people of the habit of managing their money wages, which were in fact absorbed by the co-operative shop in consequence of their value being taken in goods, whenever they were due, and in articles not of strict necessity, such as would probably have been let alone, if cash must have been paid for them. Many of the intelligent operatives having become sensible of these evils, and feeling their independence of action nullified, so to speak, signified their wish to break up the concern. Thus after a thirteen years' fair trial, the co-operative society of Belper was voluntarily abandoned by the work-people. The experiment

proved, that the open competition of common shopkeepers afforded them the best security for purchasing articles of food and clothing of the best quality, and at the most moderate price.

What I have myself witnessed at several times, both on Sundays and working-days, has convinced me that the population of Belper is, in reference to health, domestic comfort, and religious culture, in a truly enviable state, compared with the average of our agricultural villages. The factory rooms are well aired, and as clean as any gentleman's parlour. The children are well-complexioned, and work with cheerful dexterity at their respective occupations.

At Quarry Bank, near Wilmslow, in Cheshire, is situated the oldest of the five establishments belonging to the great firm of Messrs. Greg and Sons, of Manchester, who work up the one-hundredth part of all the cotton consumed in Great Britain. It is driven by an elegant water-wheel, 32 feet in diameter, and 24 feet broad, equivalent in power to 120 horses. The country round is beautiful, and presents a succession of picturesque wooded dells, interspersed with richly cultivated fields. At a little distance from the factory, on a sunny slope, stands a handsome house, two stories high, built for the accommodation of the female apprentices. Here are well fed, clothed, educated, and lodged, under kind superintendence, sixty young girls, who by their deportment at the mill, as well as in Wilmslow Church on Sunday, where I saw them assembled, evince a degree of comfort most creditable to the humane and intelligent proprietors. The Sunday scholars, equally numerous, belonging to the rural population, appeared to great disadvantage alongside

of the factory children, the former being worse clad and worselooking than the latter, and worse behaved during divine service.

Messrs. Greg spin about 60,000 lbs. of cotton per week in their five mills, which amount to the prodigious quantity of 3,120,000 lbs. per annum, being the largest concern in the kingdom\*. One penny per pound on the price of cotton wool makes a difference to them of 3000*l.* a-year.

The female apprentices at the Quarry Bank mill come partly from its own parish, partly from Chelsea, but chiefly from the Liverpool poor-house. The proprietors have engaged a man and a woman, who take care of them in every way; also a schoolmaster and schoolmistress, and a medical practitioner. The Messrs. Greg are in the habit of looking after the education of the boys, and their sisters superintend that of the girls, who are taught reading, writing, arithmetic, sewing, and other domestic avocations. The health of these apprentices is unequalled by that of any other class of work-people in any occupation. The medical certificate laid before the Factory Commissioners proves that the deaths are only one in 150, being no more than one-third of the average of Lancashire. Their ages vary from ten to twenty-one years. When they grow up, they almost always marry some of the men belonging to the factory, often continue to work, and receive better wages than the other operatives, as they are obliged to take houses for themselves. Only one or two instances have occurred in the course of forty years, since the system was begun by Mr. Greg, sen., of any of them coming on the parish. The apprentices have milk-porridge for break-

\* 308,602,401 lbs. was the import for home consumption in 1834.

fast, potatoes and bacon for dinner, and butcher-meat on Sundays. They have bacon every day. About 550 young people of this description have passed through that mill in the course of forty years. Mr. W. R. Greg says, that the general state of education among their mill hands is remarkably superior to that of the agricultural people. He has attended sometimes a sort of little club established near one of their country mills, to which some of the farmers' people came, and he found an astonishing difference between their intelligence and that of the mill-workers. He has observed, that the children are a great deal more fatigued and less willing to go to school after a holiday, than after the business of an ordinary day. They all attend school with regularity.

I paid an unexpected visit to Hyde, in order to view the factories of Thomas Ashton, Esq., uncle to the amiable youth who was shot dead some time ago near his father's door, by assassins who had hired themselves during the ferment of the spinners' strikes, to murder mill-owners at the rate of ten pounds for each. This lamented victim of violence was not a proprietor, was personally unknown to the assassins, and had never given offence to the operatives. It was an unprovoked murder, which impressed every heart with horror, and has cast upon unions a bloody stain which they will never wash away.

Mr. T. Ashton and four of his brothers possess, in their five independent establishments in the township of Hyde, 4000 power-looms, with all the subsidiary spinning machinery, and expend fully 4000*l.* weekly in wages. At the period of my visit, the work-people were paid 1000*l.* per diem in these several factories of Hyde, a district which consisted, not many years ago,

of cold clay land, ill-cultivated and thinly peopled. Along with the adjoining small townships of Duckenfield and Stayley-bridge, it contains now upwards of 60,000 inhabitants, all comfortably employed and fed.

Mr. T. Ashton's cotton-works are agreeably grouped together on a gentle declivity, which is traversed by a little tributary stream of the Mersey. This supplies the condensing power to his steam-engines, while their expansive force is furnished from rich coal-measures immediately under the factory lands. This is the motive-element which pervades and animates the region all around. The houses occupied by his work-people lie in streets, are built of stone, and are commodious; consisting each of at least four apartments in two stories, with a small back-yard and a mews lane. The rent for a good lodging, containing an improved kitchen-grate, with boiler and oven, is only 8*l.* per annum, and good fuel may be had for 9*s.* a ton. I looked into several of the houses, and found them more richly furnished than any common work-people's dwellings which I had ever seen before. In one I saw a couple of sofas, with good chairs, an eight-day clock in a handsome mahogany case, several pictures in oil on the walls, freshly painted for the family, a representation of one of the younger daughters like a smart peasant girl carrying a basket on her arm, one of the Virgin and Child at Bethlehem. and another of Christ crowned with thorns, all creditable to the travelling artist. In another house I observed a neat wheel barometer, with its attached thermometer, suspended against the snow-white wall. In a third there was a piano, with a little girl learning to play upon it.

My notice was particularly attracted to a handsome



house and shop, in one of the streets where Mr. T. Ashton's operatives dwell. On asking who occupied it, I learned it was a spinner, who having saved from his earnings 200*l.*, had embarked this capital in a retail business, now managed by his wife, a tidy-looking person, while the husband continued to pursue his profitable avocations in the mill.

Many of the factory youths of both sexes cultivate their musical tastes. The proprietor having erected a handsome school-house, the workers subscribed spontaneously among themselves 160*l.*, and bought a good organ, now set up in the gallery of the large hall of the school. It is played upon on the Sundays at divine service, and on certain evenings through the week alternately, by certain of the girls employed at the power-looms. One of them, only seventeen years of age, is said to be a tolerable organist. So much nonsense has been uttered about the deformities and diseases of factory children, that I may hardly be credited by some of my readers, when I assert that I have never seen, among a like number of young women of the lower ranks in any country, so many pleasing countenances and handsome figures, as I saw in Mr. Ashton's nine power-weaving galleries. Their light labour and erect posture in tending the looms, and the habit which many of them have of exercising their arms and shoulders, as if with dumb-bells, by resting their hands on the lay or shuttle-bearer, as it oscillates alternately backwards and forwards with the machinery, opens their chest, and gives them generally a graceful carriage. Many of them have adopted tasteful modes of wearing neat handkerchiefs on their heads, and have altogether not a little of the Grecian style of beauty.

One of them, whose cheeks had a fine rosy hue, being asked how long she had been at factory work, said nine years, and blushed from bashfulness at being so slightly spoken to. The female figures sketched in the engraving of a loom-shed at the end of this volume, are by no means fancy forms of the painter, but realities, to be seen every day at Hyde, and in many other factory districts. The specific apartment, delineated with equal spirit and fidelity, belongs to Mr. Robinson, of Stockport. The artist, at my particular desire, filled it with looms of Messrs. Sharp and Roberts' construction, instead of those adopted by the proprietor, which are of a slightly different pattern. The former are in my opinion the best, and correspond to the complete analysis of this admirable piece of mechanism to be given in our cotton manufacture.

At the elegant spinning-factory of Egerton, near Bolton, belonging to Messrs. Ashworth, I had an opportunity of judging how far factory labour, through the day, brings on exhaustion and listlessness among the young persons at night. The enlightened proprietors have encouraged the formation of schools for educating the children, and have set apart for this purpose a very commodious room; adjoining to which are conveniences for washing of hands and faces, before the lessons are begun. Three evenings a week are dedicated to the boys, and three to the girls; when several of the factory adults, competent to the task, attend and give the pupils instruction in reading, writing, and arithmetic. The progress seems to be satisfactory. What peculiarly struck me in the children, were the clearness of eye, and general liveliness, quite equal to what is seen in any ordinary day-school.

Each child pays a penny a week for education, which defrays the necessary expenses, and serves to inspire a consciousness of the value of knowledge, and of their own independence in acquiring it.

At the great establishments of Ramsbottom and Nutthall, near Bury, in Lancashire, formerly the property of Sir R. Peel, but now belonging to Messrs. Grant, similar schools for educating the factory children are conducted on the most liberal principles, and with remarkable success, under the truly maternal administration of Mrs. John Grant. Here the eye of a Scotchman may be delighted with a national church, elegantly designed, and finely situated on a picturesque eminence, a little way from the works. This structure is the pious contribution of William Grant, Esq., to the religion of his forefathers, and the edification of his work-people. It cost him 5000*l.*, besides the endowment for the minister. I had the good fortune to join, one Sunday, in its primitive worship. It was pleasing to perceive the deep interest which a numerous congregation took in the service, and the filial reverence with which they regarded their philanthropic master, at the dismissal of the church. I might easily multiply examples of endowments by individual proprietors, to show their parental concern for the children under their charge.

The overlooker of Messrs. Ashworth's mills says—“ I go round myself every morning, and see that the children wash themselves after their breakfast; and if it is discovered that they have not done so, we talk to them, and send them out to get washed. We find them in soap and towels, with hot and cold water, as much as they please.”

In towns, the tie that binds together employers and employed is of course less strong; but in the country the feelings of attachment are not unfrequently pushed to an extent that could not easily be surpassed. “The population surrounding a country mill, to the number of one or two thousand, are sometimes entirely dependent upon its master for work and subsistence; but the master is equally dependent upon them for the necessary services they perform; and whether it is that this mutual dependence is more apparent, or that the people are more civilized, it certainly seemed to me that there was less assumption of undue importance or manifestation of pride on the part of the master, and more esteem on the part of the workmen, than I ever witnessed in any agricultural district.” In this statement of Mr. Tufnell I heartily concur. It must be admitted, however, that in some small factories, chiefly of flax, there are instances in which due regard is not shown either to convenience and comfort, or to circumstances which must influence in no slight degree the moral feelings and habits of the young; but these defects are quickly disappearing.

Sufficient evidence has been adduced to convince the candid mind, that factories, more especially cotton-mills, are so organized as to afford as easy and comfortable occupation as anywhere can fall to the lot of the labouring classes.

What a pity. it is that the party who lately declaimed so loudly about the inmates of factories being universally victims of oppression, misery, and vice, did not, from their rural or civic retreats, examine first of all into the relative condition of their own rustic operatives, and dispassionately see how the balance

stood betwixt them! Decisive facts lay at their very doors, and pressed rather painfully on their organs of perception. If actuated by a philosophical spirit, they might have ascertained very soon whether Goldsmith's Auburn, or Crabbe's Village, reflected the truest picture of their *country's pride*; and by inspecting thereafter a prosperous factory village, they might have discovered whether the town was staining the country or the country the town. This preliminary analysis, which ought to have been deliberately executed, before the crusade was embattled against the cotton-mills, has, however, been well performed by the Poor Law Commissioners. From the documents published by this unexceptionable tribunal, it appears that, but for the renovating influence of its manufactures, England would have been overrun ere now with the most ignorant and depraved race of men to be met with in any civilized region of the globe. It is, in fact, in the factory districts alone that the demoralizing agency of pauperism has been effectually resisted, and a noble spirit of industry, enterprise, and intelligence, called forth. What a contrast is there at this day, between the torpor and brutality which pervade very many of the farming parishes, as delineated in the official reports, and the beneficent activity which animates all the cotton factory towns, villages, and hamlets!

The regularity required in mills is such as to render persons who are in the habit of getting intoxicated unfit to be employed there, and all respectable manufacturers object to employ persons guilty of that vice; and thus mill-work tends to check drunkenness. Mr. Marshall, M.P. of Leeds, thinks that the health of persons employed in mills is better from the regu-

larity of their habits, than of those employed at home in weaving. He considers the money wages of work-people to be as high as they were during the war, consequently the real wages measured in provisions and necessaries to be higher, and that they may of course be productive of more comforts. "Though the prices of linen yarns have fallen forty per cent., the wages have not fallen at all, because, by the improvements in machinery, the yarns may be spun at less cost. We do not employ any operatives who are guilty of intoxication."

Contrast the following description of rural life with that (in Chap. III.) given by the humble operative of a cotton-mill. "The duty of supporting children and parents in old age or infirmity is so strongly enforced by our natural feelings, that it is often well performed even among savages, and almost always so in a nation deserving the name of civilized. We believe that England is the only European country in which it is neglected\*.

"Were I to detail the melancholy, degrading, and ruinous system which has been pursued throughout the country, in regard to the unemployed poor, and in the payment of the wages of idleness, I should scarcely be credited beyond its confines. In the generality of parishes, from five to forty labourers have been without employment, loitering about during the day, engaged in idle games, insulting passengers on the road, or else consuming their time in sleep, that they might be more ready and active in the hours of darkness. The weekly allowances cannot supply more than food; how then are clothing, firing, and rent to

\* Report of Poor Law Commissioners, 8vo. p. 43.

be provided? *By robbery and plunder*; and those so artfully contrived and effected, that discovery has been almost impossible. Picklocks have readily opened our barns and granaries; the lower orders of artificers, and even, in one or two instances, small farmers, have joined the gang, consisting of from ten to twenty men; and corn has been sold in the market of such mixed qualities by these small farmers, that competent judges have assured me, it must have been stolen from different barns, and could not have been produced from their occupations. Disgraceful as these facts are to a civilized country, I could enumerate many more, but recital would excite disgust\*.”

“Good ploughmen are not to be found. The labourers say they do not care to plough, because that is a kind of work which, if neglected, will subject them to punishment, and if properly done, requires constant attention, and the lads do not even wish to learn. Nine able-bodied young men were in the workhouse last winter; such was their character, that they were not to be trusted with threshing †.”

“The veracity, the frugality, the industry, and the domestic virtues of the lower classes must be very nearly extinct ‡.”

“In the parish of Great Shelford, Cambridgeshire, the peasantry are idle, dissolute, good for nothing, and the real masters of the parish. They won't go even five miles to Cambridge, though offered employment there at twelve shillings a week. One of them being offered an acre of land rent-free, refused;

\* Report of the Poor Law Commissioners, p. 70. 8vo. edit.

† *Ibid.*

‡ Administration of the Poor Laws, p. 77.

saying he would not give up his privilege in the parish. So that an act, for which in France, Switzerland, or Germany, a man would have gained the respect and love of all the neighbourhood, creates mistrust, instead of gratitude, in the bosom of the English peasantry.”

Agriculturists give children and youths no more than half the wages paid them by factory proprietors; while they fill their workhouses with unemployed persons. Under the operation of the poor laws, the peasantry are penned up in close parishes, where they increase beyond the demand for their labour, and allow their children to grow up in sloth and ignorance, which unfit them from ever becoming industrious men. This obstacle to the circulation and reward of labour will, we presume, be ere long removed by the amended administration of the poor laws. In the chief manufacturing districts, the demand for juvenile labour is so great as to render a large family not a burden, but a source of comfort and independence to poor people. Were the parents, therefore, sober and provident, they might always train up their young ones into valuable members of society.

In very many rural districts, the mal-administration of the poor laws has banished every right feeling from the female heart; has quenched all the domestic affections; and has generated a race of harpies familiar with extortion, perjury, and violence. What can be expected of the children trained up under such mothers, but reckless idleness and profligacy? With such a monstrous brood, incendiarism becomes a sport, often wantonly perpetrated upon the barns of the industrious farmers who feed them.

In the elaborate report of Dr. Mitchell, the actuary employed by the factory commissioners, there is a table of the amount expended in support of the poor per head, for every one of the population in several counties of England; from which it appears, that in Lancashire, for the year 1821, it was only 4*s.* 8*d.*, and in 1831, 4*s.* 4*d.*; while for the same years it was for other counties of a far less manufacturing character, as follows:—

Counties.	1821.	1831.
Norfolk	14 <i>s.</i> 10 <i>d.</i>	15 <i>s.</i> 4 <i>d.</i>
Suffolk	17 <i>s.</i> 9 <i>d.</i>	18 <i>s.</i> 3 <i>d.</i>
Essex	17 <i>s.</i> 7 <i>d.</i>	17 <i>s.</i> 2 <i>d.</i>
Wilts.	14 <i>s.</i> 8 <i>d.</i>	16 <i>s.</i> 6 <i>d.</i>

The general reports of the factory commissioners demonstrated, that in almost all the great cotton-mills cases of cruelty or oppression towards the children were exceedingly rare, that they were the acts of the operatives themselves, and were not traceable to the proprietor. In a few of the smaller and older cotton-mills, evidence of over-working children was obtained. In the flax, woollen, and silk factories, which had not, like the cotton-mills, been then made the subjects of legislative regulation, there were unquestionably many instances of harsh usage of children; but these also were more the fault of the men than of the masters.

The new Factories Regulation Act applies to all cotton, wool, flax, tow, hemp, or silk-mills, of which the machinery is driven by steam-engines or water-wheels. Where the machinery is moved by animal power, the act does not apply, nor to bobbin-net lace factories.

No child can be employed at all before it is nine years old.

No child younger than eleven must work more than forty-eight hours in any one week, or more than nine hours in any one day.

After the 1st March, 1835, this restriction extends to children under twelve; and after the 1st March, 1836, to children under thirteen.

To render these restrictions effective, no child must remain on any pretence more than nine hours a day in any working apartment of the factory.

Persons under eighteen years of age must not work more than sixty-nine hours in a week, or twelve in a day; nor at all between half-past eight o'clock at night and half-past five o'clock in the morning.

Children under nine may be employed in silk-mills.

One hour and a half must be allowed for meals to all young persons, but that time is exclusive of the nine or twelve hours' work.

Two entire holidays and eight half-holidays are to be allowed to all young persons who are under the restrictions.

Every child restricted to forty-eight hours' labour in the week must attend a school for at least two hours a day, for six days out of the seven. The mill-owner is not allowed to continue in his employment any child who does not regularly attend school as above stated; for which purpose he must be certified every week of the child's attendance by the teacher.

The school may be chosen by the parents or guardians of the child. If there be no parents or guardians, the inspector takes charge of the child, and may order the employer to keep off one penny in every shilling of its weekly wages, to pay for its schooling. Attendance on a Sunday-school may be reckoned as

one of the six days. Surgeons are appointed to look into the ages of the children ; and inspectors in the several great factory districts, to see that the provisions of the Act are duly observed by all parties. They are empowered to enter any factory or mill, and any school attached thereto, at all times when such mills are at work ; to examine the children and any persons that are employed therein ; to make inquiry as to their condition, employment, and education ; to call to their aid in such inquiry, such persons as they may choose ; and to require any person on the spot, or elsewhere, to give evidence upon such inquiry, and to administer to such persons an oath.

Penalties of twenty pounds and under may be imposed for offences committed against this Act.

In order to render the present factory bill effectual, medical investigation into the age and condition of the children has been called in, to the aid of the inspectors, as a check on the certificates. Had the preceding bills been simply inoperative, they would have deserved no blame ; but they were instrumental in demoralizing both the parents and children, by leading the former to commit perjury, and the latter to become habitual liars. In fact, the perjury of the witnesses placed an effectual barrier against conviction, and compelled the masters in Manchester to abandon all attempts to enforce by law the provisions of Hobhouse's act, with regard to the age of the children and the hours of work. These masters had a lively interest in bringing all the factories under its operation, since, working themselves only twelve hours a day, they found the price of their yarn depressed in consequence of country mills working a longer time.

The operation of Hobhouse's bill at Warrington merits the attention of the humane, as it proves the injury which injudicious legislation, however well-meant, may inflict on society. The advantages to children, of factory, over other employments to which they are often put by needy parents, is made very manifest in the evidence upon that subject.

There are three considerable trades in that town ; pin-heading, fustian-cutting, and factory work. Mr. Tufnell, as factory commissioner, made a minute inspection of a great number of cottages in the poorest parts of the town, and entered into conversations with the parents, respecting the labour and comfort of their children engaged in these trades. He found that they considered factory work the best employment for them, then fustian-cutting, and lastly pin-heading—an order of preference reasonable enough. The parents said, that as they were prevented sending the children to the factory till they were eleven or twelve years old, they were compelled to send them to the fustian-cutting and pin-heading trades, in which the labour is far harder, worse paid, and apt to deteriorate the eye-sight, as also to injure the general health, by sedentary confinement in ill-aired rooms. They told the commissioner, that factory work, such as that of a scavenger in sweeping up the loose flocks of cotton from the floor, was by no means unhealthy, and that they would send their children to the mills much sooner than they did, but for the law, which obliged them to put them to more laborious employments. One woman, on being asked whether parents would say their children were thirteen or fourteen when they were much younger,

replied to the commissioner, "Ya, I'm sure I would, would'nt you \*?"

Children of a small size, and therefore young, were much more in demand during the earlier periods of the cotton-trade than they are at present, reference being had to the total number of hands employed in it, and to the amount of work done. Arkwright's water-frames were built very low in the spindle-boxes to accommodate children, and consequently sometimes caused deformity, by the frequent act of stooping to the ground. The throstle, which hardly ever requires the operative to deviate from the perpendicular posture, has for a great many years superseded entirely that machine. It is managed by young persons from fifteen years of age and upwards, and does not necessarily involve the employment of children. One girl is adequate to superintend a throstle-frame of 220 spindles. From this great factory department, therefore, children are in a great measure excluded.

Again, in mule-spinning, the number of children is not increased, but rather diminished, in reference to the number of spindles and the quantity of yarn produced, because fewer ends break upon the modern than upon the older machines. The number of mule-spinners at 35s. and 40s. of weekly wages is indeed reduced perhaps one-half, relatively to the number of spindles and of children in action, but all the docile, good hands, have got employment in the new built factories. The self-actor has already dispensed with the services of many young children, and in its further

\* Supplementary Report of Factory Commissioners, p. 226.

progress will dispense with many more, because a pair of its mules can be conducted by two adolescents of sixteen years and upwards, with the assistance of a younger scavenger to sweep up the waste cotton,—an easy occupation, on account of the height of the framework of the machine.

In an excellent mill at Stockport, mounted entirely with self-actors, six lads of eighteen years and upwards, at 14s. per week, and two young boys, conduct six self-actors, or three pairs of these automatic mules.

The principal employment of children in cotton-factories will be confined, ere long, to the piecing of the yarns in the fine spinning-mills, a task which allows them to stand or move about at their ease, during at least three-fourths of the time they remain within the walls of the factory.

Increased demand for goods, the result of extended consumption, can alone benefit the operative classes; but this result is always more or less counteracted by trades' unions, which embarrass the productive powers, spread distrust among the capitalists, and thus withdraw, so to speak, rain and sunshine from the fields of industry. Were not the efforts of these combinations self-recoiling, like the stone of Sisyphus, they would hurl ruin on the whole system of our manufactures. Beset as it now is in the departments of cotton, wool, silk, linen, iron, and steel, by the industry of rival nations, it can maintain its place in the van of improvement only by the hearty co-operation among us of head and hand, of employer and employed. Once thrown out of the market, it would, ere long, be distanced in the race, by the more frugal and docile labour of the Continent and United States.

During my late residence among the factories, several facts illustrative of the injuries inflicted on their own body by the unions, pressed themselves on my consideration. The fine spinners in Manchester, who have long enjoyed the highest wages of almost any class of workmen in the world, and are still, as we have shown, liberally paid, were the first who began to exercise control over their masters, and to convert their trade into an exclusive corporation in the rotten borough style\*, into which none could be admitted without the permission of the ruling divan. Thus the labourers set themselves in hostile array against capital, boasting their power to constrain it to their will. The masters finding, after many struggles renewed from time to time, that a reduction of wages commensurate with the fall in the price of the goods in the general market † could not be effected, had recourse to an expedient which the workmen could not decently oppose, because its direct tendency was to raise, or uphold at least, the wages of each spinner, but to diminish the numbers necessary for the same quantity of work; so that those employed would prosper, but the combined body would be impoverished. Thus justice has vindicated its lawful sway in raising meritorious individuals to competence, and depressing an obstreperous coalition. As every increase of income enables the operative to gratify more fully his luxurious habits, he never refuses

\* "I recollect a turn-out in 1802, which lasted from fourteen to fifteen weeks; that was for wages; and at that time a good mule-spinner could obtain 60s. a week, and the turn-out was among them, as it always has been; those who get moderate wages never turn out."—Aaron Lees, Esq., in First Factory Commission Report, D. 2, p. 91.

† On certain kinds of cotton-twist the fall is 50 or 60 per cent.

to undertake any additional task in the shape of a lengthened mule, for additional remuneration.

This necessity of enlarging the spinning-frames, created by the union decrees, has recently given an extraordinary stimulus to mechanical science. It is delightful to see from 800 to 1000 spindles of polished steel, advancing and receding in a mathematical line, each of them whirling all the time upon its axis with equal velocity and truth, and forming threads of surprising tenuity, uniformity, and strength. In doubling the size of his mule, the owner is enabled to get rid of indifferent or restive spinners, and to become once more master of his mill, which is no small advantage. I am well assured, that but for the extravagant pretensions of the ruling committee, this catastrophe would not have befallen the operatives for many a day to come, for two reasons; because, first, the extension of the mule is a very costly affair, and, secondly, it requires the line of spindles to be placed parallel to the length of the apartments, instead of to their breadth—the position originally designed, and the one best suited for throwing light on the yarns.

By this marvellous elongation, one spinner comes to manage a pair of mules containing from 1500 to 2000 spindles, and to supersede the labour of one or two companion spinners. The men so displaced might easily find employment upon power-looms at 15s. a week, but generally speaking, they will not condescend to this inferior task, but loiter about in idleness, consuming the funds of their society, and teaching it a lesson of moderation. Meantime mill-owners possess an abundant choice of good hands, and the power of



ensuring their best service, since they can replace them by others in case of negligence or incapacity.

The political economist may naturally ask how, with these surplus hands, the wages of the fine spinners can be maintained at their present high pitch. To this question one of the best informed manufacturers made me this reply: "We find a moderate saving in the wages to be of little consequence in comparison of contentment, and we therefore keep them as high as we can possibly afford, in order to be entitled to the best quality of work. A spinner reckons the charge of a pair of mules in our factory a fortune for life, he will therefore do his utmost to retain his situation, and to uphold the high character of our yarn."

In the factories for spinning coarse yarn for calicoes, fustians, and other heavy goods, the mule-spinners have also abused their powers beyond endurance, domineering in the most arrogant manner, as we have shown, over their masters. High wages, instead of leading to thankfulness of temper and improvement of mind, have, in too many cases, cherished pride and supplied funds for supporting refractory spirits in strikes, wantonly inflicted upon one set of mill-owners after another throughout the several districts of Lancashire and Lanarkshire, for the purpose of degrading them into a state of servitude. During a disastrous turmoil of the kind at Hyde, Stayley-bridge, and the adjoining factory townships, several of the capitalists, afraid of their business being driven to France, Belgium, and the United States, had recourse to the celebrated machinists Messrs. Sharp and Co., of Manchester, requesting them to direct the inventive talents of their partner, Mr. Roberts, to the construction of a

self-acting mule, in order to emancipate the trade from galling slavery and impending ruin. Under assurances of the most liberal encouragement in the adoption of his inventions, Mr. Roberts, who was then little versed in spinning-machines, suspended his professional pursuits as an engineer. and set his fertile genius to construct a spinning automaton.

The drawing, stretching, and twisting of the yarn had been rendered in a great measure the result of self-acting mechanism by the labours of Crompton and Kelly, the first inventor and first improver of the mule; but to back off the spiral-coil from the tip of the spindle, and then wind the thread upon it in a shapely conoid, was the Gordian knot left for Mr. Roberts to untie. The problem did not puzzle him long, for to the delight of the mill-owners who ceased not to stimulate his exertions by frequent visitations, he produced, in the course of a few months, a machine apparently instinct with the thought, feeling, and tact of the experienced workman—which even in its infancy displayed a new principle of regulation, ready in its mature state to fulfil the functions of a finished spinner. Thus, the *Iron Man*, as the operatives fitly call it, sprung out of the hands of our modern Prometheus at the bidding of Minerva—a creation destined to restore order among the industrious classes, and to confirm to Great Britain the empire of art. The news of this Herculean prodigy spread dismay through the Union, and even long before it left its cradle, so to speak, it strangled the Hydra of misrule. It is to be hoped that the manufacturers who received this guardian power from mechanical science, will strengthen with grateful patronage the arm which brought them

deliverance in the day of their distress. I have heard, on good authority, that no less than 12,000*l.* sterling were expended by the enterprising partners of Mr. Roberts in bringing the self-actor to its present perfection. Had the inventor been less ably seconded, he might have shared the sad fate of many a man of genius, have seen the offspring of many toilsome days and sleepless nights carried off by piratical marauders, and disfigured in order to make it pass for their own.

Several months ago, (December last,) this machine was in operation in upwards of sixty mills working between 300,000 and 400,000 spindles, each one turning off steadily within twelve working hours, *four* hanks of yarn on an average, of either warp or weft at the pleasure of the proprietor. The yarn is unquestionably superior in quality to that produced by hand, and may be varied in fineness by ready adjustments, from sixteen hanks per lb. up to forty hanks, a number fit for weaving excellent calicoes, fustians, and velvets. I have stood by for hours admiring the rapidity and precision with which the self-actor executes its multifarious successions and reversals of movement; and feel myself fortunate in possessing a complete series of drawings capable of conveying to any attentive student a clear conception of every lever, pulley, and wheel in this automaton of unparalleled productive power—an instrument which exhibits almost every possible variety of mechanical organization. These details belong to the cotton-manufacture. This invention confirms the great doctrine already propounded, that when capital enlists science in her service, the refractory hand of labour will always be taught docility.

Another illustration of this truth occurs in modern calico printing. This elegant art, which embodies in its operations the most exquisite problems of chemistry as well as mechanics, had been for a long period the sport of foolish journeymen who turned the liberal means of comfort it furnished them into weapons of warfare against their employers and the trade itself. They were, in fact, by their delirious combinations, plotting to kill the goose which laid the golden eggs of their industry, or to force it to fly off to a foreign land, where it might live without molestation.

In the spirit of Egyptian task-masters the operative printers dictated to the manufacturer, the number and quality of the apprentices to be admitted into the trade, the hours of their own labour, and the wages to be paid them. At length capitalists sought deliverance from this intolerable bondage in the resources of science, and were speedily re-instated in their legitimate rule, that of the head over the inferior members. The four-colour and five-colour machines, which now render calico printing an unerring and expeditious process, are mounted in all great establishments. I have seen them imparting beautiful designs, in fast colours, without any mixture of tints, to webs of white cloth running through them at the rate of a mile in the hour. Of this curious mechanism, I have also been permitted to take exact drawings, illustrative of its intimate structure and delicate adjustments, for the instruction of the public. It was under the high pressure of the same despotic confederacies, that self-acting apparatus for executing the dyeing and rinsing operations have been devised.

One day I observed placards posted throughout Man-

chester, announcing that a considerable number of yarn dressers for power-loom weaving were wanted at a well established factory, and I was led to conclude, that some of the best paid set of artisans had become refractory. A short time thereafter, on entering the engineering workshops of Mr. Lillie, I descried the corollary of the strike, in the form of a new apparatus, preparing for the purpose of enabling free labourers to dress warps, as well as the monopolists, and with threefold expedition. Thus the combined mal-contented who fancied themselves impregably entrenched behind the old lines of the division of labour, found their flanks turned and their defences rendered useless by the new mechanical tactics, and were obliged to surrender at discretion. I have since seen the sizing machine in action, dressing warp at the rate of nearly two miles in length per hour.

Violent revulsions of this nature display shortsighted man in the contemptible character of a self-tormentor. What a different lot would be his, did he quietly move onwards in the progression of improvement designed by Providence to emancipate his animal functions from brute toil, and to leave his intelligent principle leisure to think of its immortal interests! That this consummation is within the workman's reach, may be concluded from many circumstances which occurred to the factory commissioners, as well as to myself.

A mule-spinner told Mr. Tufnell, that in the intervals of labour allowed by his steam-going spindles, he had read through several books. The workmen who superintend the frames in Messrs. Boden and Morley's well regulated lace-factory at Derby, seemed

to me so much at their ease, that they might study the circle of the sciences in the course of their business, for the battalions of bobbins, though upwards of 100,000 in number, are so much under control, as to march and countermarch, take open and close order, without a moment's pause, at the bidding of the steam-engine, and with a precision never rivalled by the best drilled troops of Frederick the Great.

The price of provisions, lodgings, clothing, and fire in this country is now so moderate in the factory districts, as to render competence attainable by every frugal operative, in a superior degree to what may be enjoyed by their fellows on the Continent of Europe. America, with its vast tracts of cultivable land, is not a fair subject of comparison; because it affords in farming, an inexhaustible resource to its unemployed artisans, not to be found in the densely peopled states of the old world.

I insert the following table merely to show at how low a rate human life may be supported at present in a healthy condition in the great manufacturing emporium of England. Between that rate and the average wages of workmen, there is and ought to be, a very ample margin, which it is hoped will never be diminished, but rather enlarged, for the comfort of the industrious, by the open competition of labour.

NEW BAILEY PRISON OF MANCHESTER, FROM JULY UP TO OCTOBER SESSIONS, 1834.

*Cost of maintaining a Male Prisoner per Week in the latter part of the Quarter.*

	<i>s. d.</i>
7 Loaves of Bread, 20 oz. each at $1\frac{1}{2}d.$ per lb. . . . .	0 9 $\frac{3}{4}$
31 $\frac{1}{2}$ oz. of Meal . . . . . at 27 <i>s. 6d.</i> per load	0 2 $\frac{3}{4}$
5 lbs. of Potatoes . . . . . at 5 <i>s. 8d.</i> ditto . . . . .	0 1 $\frac{1}{4}$
1 pint of Pease . . . . . at 6 <i>s. 6d.</i> per bush. . . . .	0 1 $\frac{1}{4}$
3 $\frac{1}{2}$ oz. of Salt . . . . . at 1 <i>s.</i> ditto . . . . .	0 0 $\frac{3}{4}$
1 lb. of Beef . . . . .	0 2 $\frac{3}{4}$
1 quart of Stew . . . . .	0 0 $\frac{3}{4}$
	----- 1 <i>s. 6</i> $\frac{3}{4}$ <i>d.</i>

*Cost of maintaining a Female Prisoner per Week in the latter part of the Quarter.*

	<i>s. d.</i>
7 Loaves of Bread, 16 oz. each at $1\frac{1}{2}d.$ each . . . . .	0 7 $\frac{3}{4}$
15 $\frac{3}{4}$ oz. of Meal . . . . . at 27 <i>s. 6d.</i> per load	0 1 $\frac{1}{4}$
7 lbs. of Potatoes . . . . . at 5 <i>s. 8d.</i> ditto . . . . .	0 1 $\frac{5}{8}$
3 $\frac{1}{2}$ oz. of Salt . . . . . at 1 <i>s.</i> per bushel . . . . .	0 0 $\frac{3}{4}$
7 pints of Stew . . . . .	0 2 $\frac{3}{4}$
	----- 1 <i>s. 1</i> $\frac{5}{8}$ <i>d.</i>

W. S. RUTTER, STEWARD.

Generally speaking, on comparing the wages paid to operatives of the different classes, sexes, and ages, with the prices of provisions and other necessaries, in the Lancashire markets, it appears that all the conveniencies, and not a few of what our forefathers would have reckoned the luxuries of life, are attainable by the factory population, and are very generally to be found within their dwellings. The great point to be aimed at now, in order to uphold our pre-eminence in art, is to induce our artisans to live temperately, to husband their earnings, and to place their surplus funds to advantage. With this view, the district Provident

Society of Manchester and Salford was established in March, 1833, under the direction of some genuine philanthropists. Their objects are to encourage industry and frugality, to suppress mendicity and imposture, and occasionally to relieve sickness and unavoidable misfortune. Similar societies have since been organized in Preston, Wigan, Bury, and many other of the large manufacturing towns; and they are all advancing prosperously in their benevolent career. Manchester has been divided into districts, which are delineated in maps on a large scale, indicating every house. Thus the members of the several committees are enabled to explore poverty in its obscurest haunts.

I cannot better conclude this account of the relative comforts of our factory operatives, than with the annexed table—reminding the reader at the same time of the reduced price of provisions in Great Britain:—

Rates of Wages in the Cotton Factories of England, of the different Countries on the Continent, and in the United States.

Country.	Quantity of Raw Cotton consumed.	Hours worked per Week.	Average Wages.
England . . .	240,000,000	69	11
America . . .	77,000,000	78	10
France . . .	74,000,000	72—84	$\frac{5}{8}$
Prussia . . .	7,000,000	72—90	—
Switzerland. .	19,000,000	73—84	$\frac{3}{8}$
The Tyrol . . .	12,000,000	72—80	4
Saxony . . .	5,000,000	72	$\frac{3}{8}$
Bonn in P.ussia	—	94	$\frac{2}{8}$ *

\* Factory Commission Report, Part I., D. 2, p. 44.

## CHAPTER II.

*Health of Factory Inmates.*

THE health of factory people was made the theme of medical mystification by Mr. Sadler, in dialogues which may furnish another comic scene to the *Malade Imaginaire* of Molière. Several of the celebrated practitioners of London were summoned by him to expound to the Committee, hypothetical dogmas about the generation of disease under the circumstances of cotton-mill labour—a matter which they had never seen nor studied: and they displayed, of course, in their evidence, amusing specimens of the plasticity of the medical mind. I shall leave it to the ingenious author of *Paul Pry*, or the *Comic Annual*, to dramatize the details of the discovery then gravely recorded by the Faculty, “*that great fatigue of body and mind, with want of food, air, and sleep, are detrimental to human health,*” and content myself with noticing their more specific conclusions as to the kind of disease which ought to result from factory employment.

One ingenious physician, when asked about the effects of night-work on factory children, condemned it “because Dr. Edwards, of Paris, found that if light is excluded from tadpoles, they never become frogs;” and further, “because the Caribs, Mexicans, Peruvians, and other savage individuals, millions in number, are never deformed, in consequence of their being continually exposed to the light”! The view of mule-spinning, p. 308, will enable the Faculty to guess

at the number and brilliancy of the gas-lights in a cotton-mill, and will probably satisfy the minds of its most sceptical members that, as far as light is concerned, mill children need not linger in the tadpole state\*.

The maladies likely to result from factory labour are pronounced by some of these London oracles of *Æsculapius* to be “scrofulous diseases of every description.” “It would be scarcely possible,” says one, “to present in any brief summary the many dire effects of scrofulous disease, but we may mention, first, that the mesenteric glands are often the seat of disease. Next the absorbent glands about the neck. Then we find that the disease attacks the skin in the form of scaly eruptions, cracks, spots, ulcerations, and slowly suppurating tubercles. Again, that the eyes become affected, in the various forms of scrofulous ophthalmia, that often end in blindness; or the bones, and especially the joints, become diseased, terminating in caries of the spine and white swellings. Then, that the internal viscera are affected with tubercles—as the liver, brain, spleen, &c. And lastly, that the lungs become the seat of this destructive disease, in the form of that incurable complaint of our climate, pulmonary consumption. This is indeed a melancholy list of maladies (he subjoins), and one which, I am sorry to say, might be greatly augmented, as traceable to the neglect and improper management of those whose tender years demand and lay claim to our sympathy, and kindest care and attention; and I fear that this country will have much to answer for, in *permitting the growth of that system of employing*

\* Night-work, however, is scouted by all respectable mill-owners, as being equally unprofitable and demoralizing. See note D.

*children in factories, which tends directly to the creation of all those circumstances which inevitably lead to disease\*.*" Horresco referens!

"I believe the Committee are aware of *the fact* of the extent to which opium-eating has prevailed in the manufacturing towns†."

A great physiologist says, "Such a state as that described would be very injurious to the constitution, and engender a variety of diseases;—the great disease, emphatically using that word, is scrofula‡." And a distinguished surgeon of one of the hospitals is called to prove, "that the circumstances stated must, sooner or later, in many cases, engender scrofula, which, when once engendered, may be considered as the parent of those deformities and vices of growth, and those deteriorations of health, to which young persons, especially, are liable."

The following letter from Dr. E. Carbutt, Physician to the Royal Manchester Infirmary, &c., to the Factory Commissioners, places the absurdity of the above theoretical twaddle, and the medical reasoning in general, in a ludicrous point of view:—

"Gentlemen,—I have answered, to the best of my judgment, the several queries which you have done me the honour to submit to me; but I wish to be permitted to make a few observations upon matters not contained in these queries, more especially as to the gross exaggerations of medical witnesses, particularly those of London, on the subject of the diseases of cotton factories. These gentlemen, hardly any of

\* Committee on Factories Bill, p. 536.

† *Ibidem.*

‡ *Ibid.*, p. 603.

whom have ever had an opportunity of seeing persons employed in cotton factories, do almost universally attribute to factory labour the production of scrofulous diseases. Now the fact is, that scrofula is almost unknown in cotton factories, although the climate of this town and neighbourhood is particularly cold and humid. In a very extensive examination, which I and some other medical men made a few years ago, we found, to our surprise, that the cotton factories, instead of producing scrofula, are, in some sort, a kind of means of cure. The late Mr. Gavin Hamilton, who was for thirty-six years Surgeon to our Infirmary, and who, previously to that, had been Surgeon in the Queen's Bays, said, in my hearing, after examining a cotton factory, 'Gad! we found the factories to be a specific for the scrofula.' In one factory, examined by Dr. Holme, and Mr. Scott surgeon to the Carabineers, of four hundred and one persons employed, eight persons only were affected with scrofula, with no case of distortion of the spine or limbs." After instancing the population of several mills remarkably exempt from scrofula, the Doctor adds, "This remarkable absence of scrofula I presume, with perfect deference to the medical gentleman who is one of your number, to attribute to the dryness and warmth of the cotton factories, to the lightness of the work, and to the superior food and clothing which the superior wages of the work-people enable them to obtain.

"In addition to the above facts, I may mention that, during the sixteen years I have had the honour of being physician to the Manchester Royal Infirmary, I have, nearly invariably, at the consultations previously to operation, to which the physicians are

summoned as well as the surgeons, been in the habit of putting to the patient the question, 'What trade are you of?' especially when the case was that of a distorted limb or joint. To which question the answer has almost never been, 'Work in a cotton factory,' but almost constantly, 'a hand-loom weaver,' or 'a hatter,' or some other trade\*."

With regard to the charge against the factory people, of being opium-eaters, the following exculpatory document may suffice:—

"I cannot discover that this practice at all prevails in Manchester. The medical profession are not aware of its existence; and Mr. Williams, a druggist, who is much employed by the factory classes, declares that he has some customers, in other classes of life, who purchase large quantities of opium from his shop; but that he has never known an instance in which a factory workman procured that article from him as an article of luxury †."

During the prevalence of the cholera at Stockport, it was observed that the mill-workers enjoyed a remarkable immunity from the attack; an immunity due to the warm dry air which surrounded them while at work, and to the comforts of their homes. The cholera patients in that town were almost all females employed in private dwellings.

Not one of Messrs. Strutt's work-people at Belper was attacked with cholera, while the neighbouring handicraft people and farmers were falling victims to this pestilence.

\* Factory Commission; Appendix to Medical Reports, by Dr. Hawkins, p. 281.

† Dr. Hawkins, *ibid.*, p. 292.

The most recent, and perhaps most convincing, evidence regarding the healthiness of factory children is that given in the official report of Mr. Harrison, the Inspecting Surgeon appointed for the mills of Preston and its vicinity. There are 1656 under 18 years of age, of whom 952 are employed in spinning-rooms, 468 in carding-rooms, 128 at power-looms, and 108 in winding, skewering cops, &c. "I have made very particular inquiries respecting the health of every child whom I have examined, and I find that the average annual sickness of each child is not more than four days; at least, that not more than four days on an average are lost by each child in a year, in consequence of sickness. This includes disorders of every kind, for the most part induced by causes wholly unconnected with factory labour. I have been not a little surprised to find so little sickness which can fairly be attributed to mill work. I have met with very few children who have suffered from injuries occasioned by machinery: and the protection, especially in new factories, is now so complete that accidents will, I doubt not, speedily become rare. I have not met with a single instance, out the 1656 children whom I have examined, of deformity, that is referable to factory labour. It must be admitted, that factory children do not present the same blooming robust appearance, as is witnessed among children who labour in the open air, but I question if they are not more exempt from acute diseases, and do not, on an average, suffer less sickness than those who are regarded as having more healthy employments. The average age at which the children of this district enter the factories is ten years and two months; and

the average age of all the young persons together is fourteen years\*.”

Our legislators, when bewailing, not long ago, the fate of their fellow creatures doomed to breathe the polluted air of a factory, were little aware how superior the system of ventilation adopted in many cotton-mills was to that employed for their own comfort in either house of Parliament. The engineers of Manchester do not, like those of the metropolis, trust for a sufficient supply of fresh air into any crowded hall, to currents physically created in the atmosphere by the difference of temperature excited by chimney draughts; because they know them to be ineffectual to remove with requisite rapidity the dense carbonic acid gas generated by many hundred powerful lungs. The factory plan is to extract the foul air, in measurable volumes, by mechanical means of the simplest but most unfailing kind, especially by excentric fans made to revolve with the rapidity of nearly 100 feet per second; and thereby to ensure a constant renewal of the atmosphere in any range of apartments however large or closely pent they may be. The effect of one of Fairbairn and Lillie's four-guinea fans upon a large factory is truly admirable; it not only sweetens the interior space immediately, but renders the ingress of odorous nuisance from without altogether impossible. In a weaving-mill near Manchester, where the ventilation was bad, being dependent on currents of equilibration, as in the House of Lords, the proprietor lately caused the fan apparatus to be mounted. The consequence soon became apparent in a curious

\* Report of Inspectors of Factories for 1834 to the Home Secretary. pp. 52, 53.

manner. The work-people, little remarkable for olfactory refinement, instead of thanking their master for his humane attention to their comfort and health, made a formal complaint to him, that the ventilator had increased their appetites, and therefore entitled them to a corresponding increase of wages! The weekly pay of these attendants on steam-going looms, being nearly double of that received by labourers on the breezy plains of Sussex and Kent, could admit of no augmentation under the low rate of profits of trade. But the master made an ingenious compromise with his servants; by stopping the fan during half the day, he adjusted the ventilation and the voracity of his establishment to a medium standard, after which he heard no complaint either on the score of health or appetite.

When such a fan, placed at the one end of an apartment about 200 feet long, is in full action, it throws the air so powerfully out of it, as to create a draught at the other end of the apartment, capable of keeping a weighted door six inches a-jar. Its operation on some old and ill-ventilated mills which I have examined, is most satisfactory. When connected in the attics, with a horizontal pipe in which the vertical water-closet tunnels terminate at top, it draws out the air so rapidly from them, as to cause a breeze into every seat from the adjoining floors, and thus aërates the apartments, while it prevents any foul air from regurgitating, however careless the people happen to be. The simple and cheap contrivance of perforated boxes of cast-iron placed on every story in communication with the fan, will soon supersede, in all factories at least, the complex, expensive, and, in



common hands, easily deranged water-closet of the plumber.

The preceding ingenious and most effective plan of ventilation, was first contrived by my excellent friend Henry Houldsworth, Esq. of Manchester, and executed under his direction by Mr. Fairbairn, for the magnificent factory of Thomas Houldsworth, Esq. M.P.

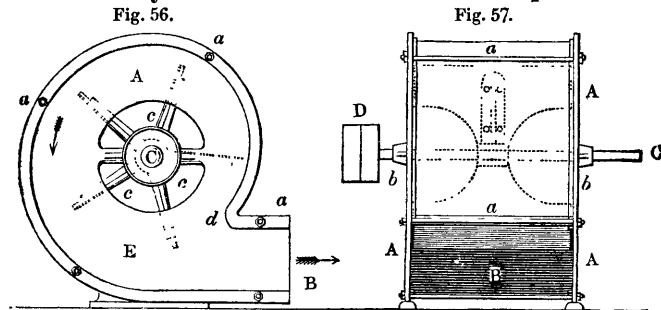

Fig. 56.—Side View of the Ventilating Fan.  
Fig. 57.—Front View of Ditto.

Figs. 56 and 57 represent a side and front view of the simple and economical fan, which has been of late years employed for ventilating factories, by drawing the air out of every apartment; for removing through tunnels the dust disengaged in cleaning their fibrous materials; for blowing air into their extensive ranges of forge fires; and many other similar purposes.

It consists of two cast-iron end plates A, A, having a central circular opening c, c, c, from the circumference of which the outline of each plate enlarges spirally, the point nearest the centre being near d, and that furthest off being under E, (fig. 56.) This pair of parallel plates is connected by bolts, a, a, a, a mantle of sheet-iron being previously inserted into grooves cast in the edges of the end plates, so as to enclose a

cavity with an elongated outlet at B, to which a pipe is attached for carrying off the wafted air in any direction. Within this cavity, a shaft C revolves, in bearings, b, b, placed centrally in the frame-plates A, A, and cast in the same piece. On this shaft, a boss is wedged fast, bearing five flat arms, c, c, c, to which are riveted five flat plates, or wires of the shape shown between a and a in fig. 57, having a semi-circular piece cut out of them on each side, about the size of the end opening. On one end of the shaft C, beyond the box bearing, the loose and fast pulleys D are fitted for receiving the driving-band, and for turning the wings in the direction shown by the arrow. Thus the air is driven before them out of the end orifice B, while it enters by the side openings, at c, c, c, fig. 56. By the centrifugal force of the revolving wings, the air is condensed towards their extremities, and makes its escape from the pressure through the orifice B, while it is continually drawn in at the sides by its tendency to restore the equilibrium. The fans constructed by some engineers have their mantles made concentric with their central shafts, and though they do good work when turned with sufficient rapidity, they are not adapted to produce pressure by condensation, as the wind issuing from the outlet B consists partly of the air compressed by the extremities of the wings, and of the air rarified on its entrance near their roots.

In the fan here represented, called the excentric, the air which escapes through the outlet B has undergone compression during its whole progress through the spiral space with the revolving wings, and is equal in density to that compressed at their extremities by the centrifugal force. This fan discharges therefore

considerably more air than that with a chamber concentric with its wings, because each wing, in passing the point *d*, acts as a valve to cut off the entrance of the uncondensed air, which would cause an eddy, and retard the proper current by the inertia of its particles.

The fan produces its greatest effect when the extreme points of its wings percur in revolving about eighty feet per second.

When the fan is employed to draw air out of a series of independent chambers, it has its circular side openings *c, c, c*, enclosed within caps, which are connected with pipes communicating with these chambers. Slide or throstle valves may be placed in the exhausting, as well as the condensing pipes, for regulating the distribution of the rarefying or blowing power.

From a most extensive comparison of facts, I am led to conclude, that the rustic population of England is less healthy than its factory population.

“Acute inflammation so frequent in country districts, which chiefly attacks those of robust and plethoric health, if not speedily suppressed by prompt and vigorous measures, is most generally fatal. Cases of this kind require immediate medical aid, which in the country is seldom to be procured without considerable delay, and often does not arrive till all assistance is unavailing.” Many ailments of the rural population are occasioned by cold, damp, marsh miasmata, and low living, which cause their whole lives to be a continued chronic disease. There is hardly one of the rustic poor when questioned as to their health, who will not give some sorrowful details of indisposition.

Dr. Kay has described Gastralgia, or morbid irri-

tability of the stomach, as prevailing much among the operatives of Manchester and the immediate neighbourhood. Having had occasion to inquire into the peculiarities of the factory people of that town, I recognised in their style of diet a very sufficient cause for gastralgia without laying the blame on their mill avocations. Bacon enters very largely into their diet, and bacon of very indifferent quality, which I found on the most careful examination to be frequently rusty—that is, more or less advanced in the process of putrefaction—an article which might be swallowed with impunity by a Cheshire ploughman in such quantities as he could afford to buy, but which will certainly produce heartburn and indigestion in persons engrossed with indoor occupation of any kind.

I tested samples of bacon as sold in several respectable shops in Manchester, and found it to be much more rank than the average in the London shops. In this *piquant* state, it suits vitiated palates accustomed to the fiery impressions of tobacco and gin. These three stimulants are too much used by that order of work-people in Manchester who receive the highest wages, and they are quite adequate to account for many chronic maladies of the stomach, liver, or spleen, without tracing them to mere factory labour or confinement. Were a judicious plan of cookery and diet, combining abundance of vegetable matter with light animal food, introduced among them, as it is among the families of the work-people at Belper, Hyde, New Lanark, Catrine, &c., joined to abstinence from tobacco and alcohol, I am confident that the health of the Manchester spinners would surpass that of any class of operatives in the kingdom: for their in-

come is such as to afford them every comfort of life, while their labour is neither so unwholesome nor so severe as that of the hand-weaver and husbandman constantly exposed to damp and cold, and earning only one-third of their wages. Hypochondriasis, from indulging too much the corrupt desires of the flesh and the spirit, is in fact the prevalent disease of the highest-paid operatives, a disease which may be aggravated by drugs, but must seek its permanent cure in moral regimen. Nothing strikes the eye of a stranger more in Manchester than the swarms of empirical practitioners of medicine. Nearly a dozen of them may be found clustered together in one of the main streets; all prepared with drastic pills and alterative potions to prey upon the credulous spinners. There is another thing which, as far as my experience goes, is peculiar to Manchester. The most *respectable* bakers (exclusive of hucksters) occupy one side of their shops with cheese (sometimes also bacon) in every stage of decay, which never fails to impart its odour to the bread exposed to the effluvia. Certainly the savour of bakers' shops in London, Edinburgh, and Glasgow is far sweeter. As a stranger who was treated with courteous hospitality, I have no motive or wish to make a single remark in a sarcastic spirit, and I have noted this circumstance merely in confirmation of my statement with regard to the insalubrious dietary of the Manchester operatives. The viands to be found upon the tables of the middling and higher classes do not yield in excellence of quality or culinary refinement to those of any metropolis in Europe.

The author of an inquiry into the state of the manufactory population prescribes as their diet "a suffi-

ciency of animal food, wheaten-bread, and malt liquor, and as little liquid of other kinds as possible." He says they may have "*occasionally, though rarely*, a small sprinkling of bacon or other meat." Since they can purchase their favourite bacon at four-pence or five-pence a pound, they need not, nor do they actually, content themselves with a *sprinkling*, for they swallow a substantial rasher. This consequently creates thirst, which must be quenched with tea at bagging-time, qualified with some ardent spirit to aid as they think the digestion of their dinner. I concur with the author above quoted, in deprecating the use of such tea as factory-people often swallow, but cannot agree with him in his recommendation of their using milk as a substitute in Manchester; for the liquid so called there is little worthy of the name. What is carried about for distribution in dwelling-houses by the milkmen is inferior even to the average London milk. The mill-owners of Manchester could, in my humble opinion, do nothing more conducive to the welfare of their operatives than to establish an extensive dairy, under the superintendence of one of their benevolent societies. It might certainly be carried on without loss to the shareholders, and with great benefit to the population. Were the work-people of the factories to adopt also the *pot au feu* cookery of the French, they might live in the most comfortable manner upon their wages. I know two talented young men now rising into merited estimation at Manchester, who while seeking insight into their business in a great establishment in London, practised the said system of diet for several years, by which small pieces of animal food

are made to impart a relish to a large quantity of esculent and farinaceous vegetables of various kinds. An oil lamp with a feeble flame supplied them with heat enough to stew the mingled materials in a tin sauce-pan during the interval between the breakfast and the dinner-hour—and to keep it hot for their table. On this plan they ascertained that they could board themselves comfortably for 2*s.* 6*d.* each per week. The most savoury and salubrious cookery requires the slowest fire. A sumptuous French dinner could be dressed with one-tenth of the fuel consumed by an English cook in broiling a few beef-steaks or mutton-chops.

The author above-quoted compares the work of *spinners and stretchers* in a cotton-factory with that of mowers of hay. I have tried my hand slightly at both occupations, and feel warranted to declare that the comparison is preposterous. The mower, in sweeping round his ponderous scythe, must throw every muscle of his arms, body, and legs into a violent *nisus*, and may therefore soon feel fatigue. But the spinner has to make merely a succession of moderate efforts recurring at intervals of half a minute or more, when he slowly pushes in the carriage of the mule upon its friction-roller railway, after which he may stand at ease during three-fourths of the current time at least. The standing or sauntering posture of the carders, rovers, piecers, and weavers in a factory are compared by him to the penal walking for twenty-four continuous hours inflicted on English witches in former times. On this absurd similitude I shall merely remark, that the standing or walking upon the spacious floors now

allotted to factory work-people seems to agree well with the "*fatal sisters*" of Lancashire, who "weave the woof of victory" over their country's rivals.

Mr. Kempton, a respectable manufacturer in New England, assured our central board that factory labour for twelve or fourteen hours is not found to be injurious to the health or growth of the children of ten years of age and upwards in the States, because they are well fed, their board being paid out of their wages by the proprietors,—an excellent practice, which would not, however, be permitted by the pauper parents in this country, who live too much upon their children's earnings. In their manufacturing districts, upwards of 4000 children are employed under twelve years of age.

The evidence collected by our pains-taking commissioners proves, that under such a diet as the wages could afford, the young inmates of our factories would thrive equally well with the American. And as to the charge which has been made of the injury done to their constitutions by entering a factory in early life, the following refutation of it is most decisive. "There is one thing I feel convinced of from observation, that young persons, especially females, who have begun mill-work at from ten to twelve, independently of their becoming much more expert artists, preserve their health better, and possess sounder feet and legs at twenty-five, than those who have commenced from thirteen to sixteen and upwards\*."

"At the Blantyre mills," says the same competent observer, "the spinners are all males. I visited the dwellings of nine of that class without making any

\* Sir David Barry, M D., Second Factory Commission Report, p. 4.

selection. Found that every one of them was married, and that the wife had been in every instance a mill-girl, some of these women having begun factory work so early as at six and a half years of age. The number of children born to these nine couples was fifty-one; the number now living forty-six. As many of these children as are able to work, and can find vacancies, are employed in the mill. They all live in rooms rented from the owners, and are well lodged. I saw them at breakfast time, and the meal was composed of the following; viz. porridge and milk for the children; coffee, eggs, bread, oaten cake, and butter for the father. I have the notes taken on the spot beside me, but think it needless to transcribe them at full length.

“A most extraordinary degree of attention is devoted in the New Lanark mills to the education of the children of the workers, candidates for admission to employment in the mills. They are taught reading, writing, with the elements of geography, music, dancing, natural history, &c. in fine spacious rooms. I witnessed considerable proficiency in some of these branches, and saw eight young persons, from ten to thirteen, dance a quadrille in the very best style, under their dancing-master. Employment in the mill is looked forward to by these children with much ambition, as the reward of diligence in their studies. It is quite clear that Mr. Walker, the managing resident partner, devotes the kindest attention to his people; he is beloved by them all. About 300 of the oldest pupils pay 4*d.* a month towards the expenses of their education; and there are 150 of the youngest, from three or four to eleven, who pay nothing. The spin-

ners in this mill are all females except nine, who are retained as old and faithful servants. Seven of these are married to factory girls, and have had born to them thirty-five children, twenty-six of which are now living. One spinner is married to a woman who has worked *thirty-two* years in this mill, who is but thirty-nine years of age, and in excellent health\*.” The yarn spun is throstle twist.

Sir David Barry's evidence, relative to the growth and development of females engaged in factory employment, is peculiarly valuable, as being the result of personal inspection. “Many of the girls were beautifully formed, who had been from ten years of age to maturity in the mill. I noticed five sisters, from thirteen upwards, all employed in the mill from their childhood, every one of whom might be termed a fine-grown girl; some of them remarkable for symmetry and strength. This day I examined carefully and individually one hundred and eleven girls of the classes stated, with a view to find, if possible, a case in which the plantar arch (the hollow of the sole) had been broken down by continual standing, as is stated in the evidence lately printed (Mr. Sadler's Committee) to occur sometimes in factory workers. Found many beautifully-formed feet in those who had worked the longest. In no case did the plantar arch seem to have been in the slightest degree disturbed. Nothing but the evidence of my own senses could have induced me to believe that girls, indeed any human beings, worked as stated from nine years upwards, could yet possess in maturity the apparent extreme of high

\* Sir David Barry, M.D., Second Factory Commission Report, p. 53, A. 3.

health and vigour, with finely-proportioned forms. It is quite impossible to give an adequate notion of the quickness and dexterity with which two girls, about thirteen years of age, joined their broken ends of threads, shifted the pirns, screwed and unscrewed the flies, &c. To supply the place of such artists by new hands would be utterly impracticable, and difficult in the extreme to find a relay of hands equally expert under present circumstances. There is no sameness of attitude, no standing still; every muscle is in action, and that in quick succession\*."

"The most remarkable persons in the splendid calico-printing establishment of Mr. H. Monteith, at Barrowfield, Glasgow, are twenty adult females, termed stove girls. They hang up the prepared webs in the stoves to dry, and afterwards take them down. They earn 7s. 6d. per week. I have been in the stove and seen them at work around me, whilst the thermometer in my hand marked 140° Fahr. I was informed by the over-looker that it often stands higher. As the wet cloth is drying, the temperature sinks a few degrees. These girls are constantly passing through the open air from one stove-room to another, but remain only a few minutes in each. Mr. Rodger, the benevolent manager of the works, informs me that candidates for this department are never wanting; tall girls, and rather thin, are, however, preferred. Each is provided with fine flannel chemises by the proprietors, which are constantly worn. Some are very fine-looking girls, and all appear to be in perfect health. They work barefooted, and have often leisure to sit. Mr. R. states that they are as healthy as any

\* Second Factory Commission Report, p. 3.

girls in the establishment, and that when any of them happen to catch cold, they are very soon cured by going into the stove again\*." The high temperature and rapid desiccation are thought to improve, or at least to fix the colour of the Turkey red goods, for the beauty of which Mr. Monteith's house is so justly celebrated all over the world.

At Anderston, near Glasgow, there is a long building, which was erected many years ago by Mr. H. Houldsworth, to serve for dwelling-houses to the people employed in his extensive cotton factories. A corridor runs the whole length of the building; on one side of which the entrance doors to the lodgings are placed. The people crowd, to the number of 500, into these barracks, as they are called, and are so careless of cleanliness and ventilation, in spite of every remonstrance of the proprietor, that they have been frequently visited with typhus fevers of the most malignant and fatal type. At length science has enabled him to effect a reform, which reason and authority had long attempted in vain. He has led along the ceiling of the corridor a large iron pipe, shut towards the door of the passage, and connected by a valve at its other open extremity, with the great chimney of the mill. From the side of this horizontal pipe, opposite to each house, a tin tube  $1\frac{1}{2}$  inches in diameter branches off at a right angle, and enters through the wall, so as to present its open end immediately over the bedstead of each apartment. Whenever the steam-engine is stopped, either at meal hours or at

\* James Stuart, Esq., A. 3, p. 39, Supplement Report of Factory Commissioners. I can join my testimony in full confirmation of his, having often witnessed the above drying operations.

night, the mechanism which shuts the fire-damper is so constructed as to open at the same instant the valve at the inner end of the corridor pipe; whereupon a brisk current is established in each tin tube, and a stream of air rushes into it from every apartment. Since the introduction of this self-acting and most powerful system of ventilation, the factory barracks have been not only completely delivered from every appearance of pestilential fever, but have become, in fact, a remarkably healthy habitation.

Dr. Hunter, the distinguished physician of Leeds, gave the following evidence to the factory commission. "Generally, I consider the adult population in the clothing departments of Yorkshire a strong, robust, and healthy class of men. I have remarked this many years ago. Take 1000 of the native men of Leeds employed in the clothing business, and an equal number, both taken indiscriminately, from the inhabitants of any of the adjoining rural towns, say Otley, Ripon, Wetherby, Tadcaster, or even York, I am convinced that the men of Leeds will be found more muscular and fleshy, to cover more ground, and to be rounder over the chest; and where they are temperate and regular in their habits, they live as long. I have often made this comparison in my mind when visiting these towns; and I will admit the same comparison between the women and children. The reason is plain; the Leeds people are better fed. I can point out in the hospital books cases of old men from seventy to eighty-two who have stated that they were clothiers all their lives. I have no reason to think those men engaged in the flax trade are much inferior, where the wages are as good. The paler appearance

of the inhabitants of towns, and of those working under cover, proceeds from natural causes, and is by no means incompatible with good health. I have often been surprised to see grave arguments founded on such appearances, which a moment's reflection might explain. Natural paleness, and that paleness proceeding from bad health, are readily distinguished by the town practitioner. For the same reason I attach no weight to those assertions which mention that the factory children can be easily distinguished from the other children at schools and other meetings. Let any given number of the factory children and those of the same class in the town be dressed alike, the most experienced person will not distinguish them either by their gait or appearance. This fallacy arises from seeing the children in their working dress going and returning from the mills.

"I do not consider the factory population in this town more immoral than the same class out of the mills. I have always found them, male and female, as modest in demeanour as any other class of working people\*."

Mr. Wildsmith, town surgeon of Leeds, says, that "the present hours of labour are not injurious even to the younger branches, as far as their health is concerned. As a proof that the people do not consider factory labour so, even the tenterers, or those who work in rooms heated to 150° Fahr., and the fullers, sizers, and millers, who work constantly amidst water, are admitted into benefit societies upon the same terms as others†.

\* Second Report Factory Commission, C. 3, p. 17.

† Second Factory Commission Report, A. 3, p. 53.

The returns procured by Mr. Thorpe, of Leeds, justify the assertion, that the mortality of that town has diminished since 1801, at which time there were scarcely any manufactories established in it. The population of the township was, in 1801, 30,669; and the burials of the three years preceding being 2882, or 941 annually, the resulting rate of mortality is one in thirty-two and a half. In 1831 the population was 71,602, and the burials of the three years preceding were 5153, or 1718 annually, giving a rate of mortality of one in forty-one and a half. Thus, since the comfortable wages of factory labour have begun to be enjoyed, the mortality has diminished in the proportion of thirty-two and a half to forty-one and a half; that is, only three persons die now, where four died in the golden age of precarious rural or domestic employment. The decriers of the factory system who seek to demonstrate the decay and debility of the people of England by statistical tables fallaciously constructed, should be reminded how small a proportion of the whole population are actually engaged in factory labour, in those towns which have been instanced as exhibiting its fatal effects. The following is an accurate return, obtained through the overseers of the several divisions of the township of Leeds, of the precise number of persons engaged in the manufacture and finishing of woollen yarn and cloth, worsted, flax, silk, and cotton.

Manufacture.	Males.	Females.	Total.
Wool	4,064	1,226	5,290
Worsted	306	396	702
Flax	889	1,545	2,434
Cotton	17	63	80
Silk	42	116	158
Total.	5,318	3,346	8,674

These returns are exclusively from the township of Leeds. The two largest flax-mills, those of Messrs. Marshall and Co., and of Messrs. Benyon and Co., are in Holbeck. For the workers employed in them, 2000 may be added. The total population of the two townships was, in 1831, 82,812. The woollen manufacture, as carried on at Leeds, is acknowledged on all hands to be healthy. Mr. Thackrah, of that town, in his book on the effect of trades on human life, says of the carding pieceners, that they are generally the most robust children of the place. The imputation of unhealthiness is attached by Mr. Sadler and his partisans only to the flax, worsted, cotton, and silk; in the whole of which factories it appears that a number not greater than 5374 persons are employed out of 82,812, about one-fourth of whom are above the age of twenty. Hence, only about 4000, or less than one-twentieth part of the population under that age, are at factory labour. The credulity of the public is therefore called upon to believe that the mortality of the *whole* population of 83,000 persons is affected to the dreadful extent blazoned abroad, by an increased mortality, in its *twentieth part!* Even supposing the whole 5374 persons to



be under twenty years, and all engaged in the most deleterious process of factory labour, the proposition is intrinsically absurd. Again, the females employed in the woollen, or wholesome trade, form only  $\frac{1}{4}$  of the workers, while in the flax, or unwholesome trade, they form  $\frac{3}{4}$ ; and yet their expectation of life, from the Leeds returns, appears to be, by comparison with Mr. Rickman's tables for the whole of England, better than that of male life, by more than the average difference between the two values\*.

One of the most valuable accounts of general sickness among the poorer classes is that contained in Mr. Finlaison's Report on Life Annuities, printed in 1829. It does not go below the age of twenty, and yet it shows that seven days in the year is the average duration of sickness among the labouring classes in London, between the ages of twenty and thirty-five; implying, probably, such sickness as would entitle the invalid to receive sick pay from a benefit society. From the returns of the cotton-mills, it appears that this amount exceeds very far any degree of sickness known in them, even during the fickle health of childhood. Out of 376 persons employed in Messrs. Greenwood and Whitaker's cotton-mill, the average time lost by sickness is only *one-third of a day per annum*.

Mr. Hutton, who has been in practice as a surgeon at Stayley Bridge upwards of thirty-one years, and, of course, remembers the commencement, and has had occasion to trace the progress and effect, of the factory system, says that the health of the population has much improved since its introduction, and that they

\* See Mr. Drunkwater's excellent observations in First Factory Commission Report.

are much superior in point of comfort to what they were formerly. He also says that fever has become less common since the erection of factories, and that the persons employed in them were less attacked by the influenza in 1833, than other classes of work-people. Mr. Bott, a surgeon, who is employed by the operatives in Messrs. Lichfield's mills to attend them in all cases of sickness or accident, at the rate of one halfpenny a-week (a sum which indicates pretty distinctly their small chances of ailment), says that the factory workmen are not so liable to epidemics as other persons; and that though he has had many cases of typhus fever in the surrounding district, nearly all the mill-hands have escaped, and not one was attacked by the cholera during its prevalence in the neighbourhood\*.

It is perfectly true that the Manchester people have a pallid appearance; but this, for two reasons, is certainly not attributable to factory labour: first, because those who do not work in factories are equally pallid and unhealthy-looking with those that do, and the sick-society returns show that the physical condition of the latter is not inferior:—secondly, because the health of those engaged in country cotton factories, which generally work more hours than town ones, is not injured even in appearance. Many a blooming, cheerful countenance may be seen in Mr. Ashton's mill, at Hyde, among operatives working twelve hours and a-half daily, which is half an hour longer than any mill in Manchester. The apprentices in Mr. Greg's mill at Quarry Bank, near Wilmslow, are equally well-looking.

\* Page 56, Second Factory Commission Report.

Mr. Wolstenholme, surgeon, at Bolton, says that "The health of the factory people is much better than their pallid appearance would indicate to any person not intimately acquainted with them." In Bennet-street Sunday-school a comparison was made of the factory and non-factory children, by separating each at different sides of the school-room; and, on contrasting in this way more than 1000 children, none of the gentlemen of the Factory Commission could detect the smallest difference in their personal appearance.

The temperature of the apartments in which the children work has been much talked about,—a circumstance specially urged against fine-spinning mills. Now, in Manchester, whenever the temperature of the external air is genial, no artificial heat is used in the fine-spinning mills, which never require a heat above 75° Fahr., as several respectable witnesses prove on oath. It is an error to suppose that moderately high temperatures are injurious to health, if a circulation of air be kept up. It is foul air, and not warm air, which is hurtful to life. The stovers, in bleach-works and print-works, hang their cloth in temperatures much above 100° Fahr., and do not appear to suffer inconvenience from it, though they frequently leave the hot room for the open air. Messrs. Binyon and Nield mention (page 45, *Second Report*) that they had made inquiry about some boys who had been employed in the drying-room of a calico print-work, heated to 112°, for four years, and they found that they had never had occasion to leave their work from indisposition.

That the spinning-rooms in a cotton factory can be

crowded is utterly impossible, from the nature of the machinery. The mules, in their advancing and retreating locomotion, must have five or six times the space to work in that the actual bulk of the mechanism requires. Now, nine-tenths of the children are employed tending these open-spaced mules. Any one who has once visited a cotton-spinning room must be aware of the impossibility of unduly crowding human beings in a mule apartment. Nor are any of the other rooms crowded with workers, for this plain reason, that no useful purpose could thence result to the manufacturer. "It would be," says Mr. Tufnell, "an outrageous falsehood to assert that any part of a cotton-mill is one-tenth part as crowded, or the air in it one-tenth part as impure, as the House of Commons with a moderate attendance of members."

The only labour in cotton factories that seems to have any tendency to produce deformity is throstle-spinning, at which, however, young children are never employed, but only adolescents of sixteen and upwards. The action which may inflict injury on the negligent is stopping the spindle—an operation which is often performed by standing firm on one leg, and raising the other on tiptoe, so that the knee is brought in contact with the spindle, and stops it by friction. It may be difficult to conceive how this momentary attitude can occasion deformity, as it is by no means an unnatural one, and is, in fact, often assumed by every person unconsciously: but the injurious effect arises from the frequency with which the operation is repeated; namely, whenever a thread breaks. It is, however, altogether the workman's fault if deformity is produced, as he can stop the spindle as easily with

his hand as his knee, or with each knee alternately—expedients which the prudent always use, and thereby protect themselves from every inconvenience. Simple and well-known though the preventive may be, it is difficult to get work-people to practise it, from the well-known influence of listlessness and habit. Thus it was found impossible to get the Sheffield dry-grinders and needle-pointers to use the magnetic mouth-piece as a preventive against the inhaling of the particles of steel, though early decline and death are the infallible consequences of their refusal. One thing is certain, that be the deformities occasioned by throstle-spinning what they may, a factory bill will not remedy the evil, unless it can compel every workman to stop his spindle at all times with his hand, instead of his knee, or with each knee alternately. All the deformed persons produced before the Factory Commissioners were adults ;—there was no case adduced of a child deformed by its work. The reason is, that, many years ago, it was the practice to work much longer hours than at present, in consequence of which several persons who were then injured by overwork and their own carelessness, are now to be met with. But a far better reason for deformity being so much less frequent than formerly is the disuse of the old spinning-frame, which was made so low, for many years after its invention by Arkwright, that many thousand persons were deformed by working at it, before the introduction of the throstle machinery.

In most mills the dangerous parts of the machinery are so well fenced off that it is almost impossible for an accident to occur ; and when one does happen, which is very rarely, it is generally through some

gross negligence or misconduct in the person injured. Fatal accidents are not one-twentieth part so common in cotton factories as in coal mines. Among the 1100 persons employed in Mr. Ashton's mills, only one fatal accident has occurred in fifteen years, and that was owing to a man going into a room which he had no business to enter, getting a ladder, for what purpose nobody knows, and mounting to the top of the room, where he was caught by a horizontal shaft, and instantly killed.

Upon the subject of this chapter the admirable investigations of Messrs. Cowell, Tufnell, and Drinkwater, may be read with advantage. They display a perfect mastery of the inductive method of research, and leave no fallacy unexposed. See the 1st and 2d Factory Commission Reports, and the Supplement. I have drawn freely upon them as a fund of genuine information.

## CHAPTER III.

*State of Knowledge and Religion in the Factories.*

IN considering our factories in reference to the comforts and health of their inmates in the two preceding chapters, some illustrations which more properly belong to this chapter have been unavoidably anticipated, since for the physical well-being of man a sound mind must actuate a sound body.

The most flagrant reproach of this Protestant kingdom is, the uneducated state of the lower orders, and the ill-educated state of the higher. While the former defect is the dark den of incendiarism and misrule in the farming districts, which, if not cleared out, will give birth ere long to disastrous eruptions in every other province; the latter vice has been the prolific parent of a never-ceasing round of political and legislative blunders, under the consequences of which no people less energetic than the middle classes in Great Britain could have upheld their heads. Grandees, as the spoiled children of the state, may be indulged in their learned play-things, as in the ribbon and the star, to mark their exclusive caste, and they may be allowed freely to waste their early years in the pastime of scanning Greek and Roman metres, provided they do not fancy themselves thereby, albeit ignorant of the principles of Science, Art, and Trade, qualified to scan the measures and to regulate the affairs of empires at their will.

After the reports on the Poor Laws had exposed in noon-daylight, the horrid results of want of education in the agricultural hamlets of England, it was a piece of singular effrontery in the feudal legislators to accuse the manufacturers of being the main authors of the national corruption, and to require them, under heavy penalties, to be responsible for the education of all the juvenile operatives whom they employ. What a tumult would such an enactment make, if applied to the dependent population of the rural members of either house of parliament! Why were not the territorial and ecclesiastical aristocracies summoned, in the same summary way, to shed mental light over their dark domains? Had due provision for instructing the juvenile poor been made by them in their respective parishes, as in Christian duty bound, the children ten years old, whom agriculture could not beneficially employ, would have been received and supported by the factories, and further nurtured in salutary learning at the excellent evening and Sunday-schools attached to them. The twenty-first clause of the Factories Regulation Bill is an act of despotism towards trade, and of mock philanthropy towards the work-people who depend on trade for support. It requires every factory child, twelve years of age, to produce every Monday morning a certificate of having attended school for two hours at least, on six days of the preceding week, on pain of dismissal from the mill in which he earns his livelihood. Against this absurd law, strong remonstrances have been made by the real friends of the poor. Few mills, in fact, are situated near schools which are open at hours convenient for these busy children, namely, early in the morning and late in the evening; and therefore

to make the requirement practicable, one or more factories should have a school, or schools, subservient to them, open at suitable times of the day. The school clauses exhibit an ingenious sample of legislative wisdom ; for they have had the diametrically opposite effect of their avowed purpose. Instead of protecting and improving the condition of the children, the supposed victims of the mill-owner's avarice, they have deprived them of the means of subsistence, causing them to be turned adrift to sympathize with the listless progeny of the farm-labourer.

The mill proprietor, after finding that this factory act, like its predecessors, was the fruitful parent of deceit and perjury to the young operatives and their guardians, and a law-trap to himself, has had no alternative but to dismiss from his works all children under twelve years of age—an event fraught with widespread privation. The children so discharged from their light and profitable labour, instead of receiving the education promised by parliament, get none at all ; they are thrown out of the warm spinning-rooms upon the cold world, to exist by beggary or plunder, in idleness and vice,—a life wofully contrasted with their former improving state at the factory and its Sunday-school.

After the 1st of March, 1836, all children, even up to thirteen, will be in danger of being dismissed from factory employment, by a prospective ordinance which, under the mask of philanthropy, will aggravate still more the hardships of the poor, and extremely embarrass, if not entirely stop the conscientious manufacturer in his useful toil. This law will no doubt be evaded in many ways by the indignant artisans, whose families it tends

to starve, and it will thus prove operative only for evil, by perverting their moral principles. A proprietor of a large factory in Manchester lately told me, that on the 1st of March this year, having discharged thirty-five children as being under the proper age, he was surprised to find that within a week or two, the whole of them had resumed their work under the sanction of legal surgical certificates, which the managing partner of the concern had no leisure to investigate, and could not reject.

The paramount importance to the state of providing good education for the children of the poor, before ten or eleven years of age, in every part of the kingdom, but especially in the factory districts, will appear from the following considerations.

Manufactures naturally condense a vast population within a narrow circuit ; they afford every facility of secret cabal and co-operative union among the work-people ; they communicate intelligence and energy to the vulgar mind ; they supply in their liberal wages the pecuniary sinews of contention, should a spirit of revolt become general, and the ample means of inflaming their passions and depraving their appetites by sensual indulgences of the lowest kind. Persons not trained up in moral and religious nurture, necessarily become, from the evil bent of human nature, the slaves of prejudice and vice ; they can see objects only on one side, that which a sinister selfishness presents to their view ; they are readily moved to outrage by crafty demagogues, and they are apt to regard their best benefactor, the enterprising and frugal capitalist who employs them, with a jealous and hostile eye.

The interest excited by the factory operatives be-

comes greatly more intense, when we consider the vast value and exquisite nature of their workmanship, and the mighty influence which their labours exercise upon the prosperity—nay, the very existence of the kingdom at large. The total value of the exportations of produce of the United Kingdom last year, was 36,541,296*l.*; of which fully 30,000,000*l.* consisted in manufactured articles of cotton, wool, linen, and silk—the subjects of this volume. National bankruptcy and beggary, with a dismantled army and navy, would be the result of any great convulsion among our factory population. This catastrophe ought to be deprecated with the most solemn adjuration by every patriot, and counteracted *in ovo*, so to speak, by a wise and liberal policy.

I indeed apprehend no such result, because I believe there is an abundant increase of intelligence and moral sentiment springing up among the factories, the fruits of Sunday-schools and other philanthropic establishments—planted and upreared chiefly by the work-people themselves, unaided by opulence, and unpatronised by power. It is a sublime spectacle to witness crowds of factory children arranged in a Sunday-school. I would exhort the friends of humanity, who may chance to pass through Cheshire or Lancashire, not to miss a Sunday's visit to the busy town of Stockport, which joins these two counties. It contains 67 factories, in which 21,489 operatives of all ages are employed comfortably for their families.

The Sunday-school of this place was erected by the voluntary contributions, chiefly of mill-owners, in the year 1805. It is a large, plain, lofty building, which cost 10,000*l.*, having a magnificent hall for general examinations and public worship on the uppermost

story, capable of accommodating nearly 3,000 persons, besides upwards of forty comfortable apartments for the male and female schools, committee and library rooms, on the other floors. On the 16th of June in the above year, the committee, teachers, and children of the then existing Sunday-Schools assembled on the elevated site of the new building to celebrate in a solemn manner the commencement of this noble enterprise, the foundation-stone having been laid the evening before. Many thousand inhabitants of the town and neighbourhood having joined them, the whole multitude raised their voices in a hymn of praise to the Father of Light and Life, in which they were accompanied by a full band of music. The treasurer then pronounced a solemn prayer, dedicating the intended edifice to God, and imploring his blessing on its objects. In a concluding address he said,—

“Our meeting together this day on this spot has nothing in it of parade or show—nothing that can allure the eye by its splendour, or beguile the imagination by its pomp. It is nevertheless of the highest importance, to the rising generation, to the town of Stockport, and as far as its influence extends, to the nation. We meet to erect a perpetual standard against ignorance and vice, to confirm and render permanent an establishment intended to train up the children of this town in knowledge and virtue.

“We expect thousands of children will here be taught not only the grounds of human science, but the first principles of the Christian religion; that religion, which is the true source of all sound morality, of all public and private virtue. This building is to be erected and maintained on the principle of pure

and genuine benevolence, and is intended to consecrate as much of the piety and charity of this town as will supply a succession of gratuitous teachers. I feel happy to declare thus publicly the sentiments of the committee, that this building is not to be confined to any sect or party, nor to be under any exclusive direction or influence. Learning is intended to be put in its proper place, as the handmaid of religion; and whatever human science is taught, is to be rendered subservient to this important purpose."

In the annual report of this admirable institution for 1833, the committee state, "that, since its commencement, the names of 40,850 scholars have been inscribed on our registers, a considerable part of whom have received a moral and religious education within our walls. Part of the fruit of these pious labours is already reaped in a temporal point of view, in the general decorum that pervades this town and neighbourhood, and the regard for the liberties, lives, and properties of others, evinced by the Stockport population at a period of political excitement, in which they were too much disregarded at other places. The well-judged liberality of the public has now made Sunday-schools so numerous in our borders, that it is hardly possible to approach the town of Stockport in any direction without encountering one or more of these quiet fortresses, which a wise benevolence has erected against the encroachments of vice and ignorance. The advocates of general education hear no more of the danger of educating the lowest classes; on the contrary, the necessity of doing so is generally insisted upon—the people are extravagantly complimented upon the proficiency they have already made,

and appear to be in as much danger of suffering from the effects of artful and injudicious flattery, as they have done in times past from the unnatural neglect with which they have been treated."

When I visited this school a few months ago, there were from 4000 to 5000 young people profiting by the instructions administered by 400 teachers, distributed into proper classes, and arranged in upwards of forty school-rooms, besides the grand hall in the top of the building. I witnessed the very gratifying sight of about 1500 boys, and as many girls, regularly seated upon separate benches, the one set on the right side, and the other on the left. They were becomingly attired, decorous in deportment, and of healthy, even blooming complexions. Their hymn-singing thrilled through the heart like the festival chorus of Westminster. The organ, which was excellent, was well played by a young man who had lately been a piecer in the spinning factory of the gentleman who kindly attended me on the occasion.

In visiting the several school-rooms, I observed that each subordinate teacher usually concentrated his attention to one bench of children, about ten or twelve in number; whereby he was enabled to place his mind in contact, so to speak, with the mind of each, and thus remarkably to facilitate their acquisition of knowledge. The proficiency made by some of them in learning, from Sunday teaching alone, is truly wonderful, and indicates a zeal in the gratuitous instructors, and a docility in the pupils alike laudable. The Lancasterian school method is in as little credit at Stockport, as in Prussia, where it is established as an axiom in education—*as is the teacher, so is the scholar.*

The unrivalled growth of the factory establishments of Stockport, which work up now, it is said, as much cotton as those of Manchester, may be fairly ascribed, in no small measure, to the intelligence and probity of the recent race of operatives trained up in the nurture of its Sunday schools. It possesses a population considerably exceeding 50,000, quietly engaged in industry through the week, and devoted to religious exercises on the Lord's day. I have never seen any manufacturing town of such magnitude so exemplary in this respect. The frontispiece, and concluding plate of this volume, represent the exterior and interior of two of its excellent cotton-works.

Scotland possesses many factories set down on its romantic streams, among a rustic population; and these may therefore be examined with advantage as to the influence of mill employment on education and conduct. The first in date, or at least in consequence, was that erected by Mr. David Dale, near Lanark, upon the falls of the Clyde. Distinguished for his piety, as well as enterprise, this gentleman established a system of discipline for discouraging vice and irreligion, which, if every other mill-proprietor had done, the agricultural labourers of England would long ere now have been shamed out of their improvidence and profligacy, and no factory committee or commission would ever have been talked of in the British parliament. His philanthropic plans have been so judiciously carried on by his successors, as to secure to New Lanark mills a merited celebrity all over the world; and to afford the clearest evidence that factory labour is not incompatible with contentment and virtue. The school for the instruction of the young,

and the apartments attached to it, are magnificent. Medical attendance is afforded to all the workers gratuitously, upon all occasions, at the expense of the company, and every other comfort is provided consistent with their condition. Spinning of twist yarn is the sole business of the establishment, and is performed mostly by women, whose general aspect is blooming, and as unlike as possible to the pale, languid-looking females who, amid the contagious habits of great cities, pursue a similar avocation. The village in which the workers live belongs to the proprietors, and is neatly built. It contains 2000, of whom 930 are actively employed. Three mills, containing twenty-four working apartments each, are in action; and a fourth is in process of being built. From twenty-three to twenty-four tons of cotton are spun in them every week, on 40,000 spindles, partly on throstle and partly on mule machines, impelled by seven great water-wheels of about three hundred horses power.

Two teachers are salaried by the company for instructing the young persons at the school every evening, except on the Saturdays, in reading, writing, accounts, music, and dancing; and they find the scholars as diligent now as at any former period. A sick fund has been established by payments from the workers, of a penny out of every five shillings which they earn, from which the sick receive a certain weekly allowance. When there is any deficiency in their funds, the company uniformly make it up, so that work-people absent from indisposition are never destitute of support. Little strong liquor of any kind is



taken by the operatives, water being the usual drink at dinner. Many of the females wear silk dresses on Sunday. The wages of a male spinner are from 16s. to 1*l.* a week; of a female spinner, from 7s. to 9s. or perhaps a little more; and of the children, from 1s. to 6s. 6*d.* The operatives, male and female, are as well behaved in their moral conduct as any part of the neighbouring population, which not being corrupted by an ill-administered poor-law, is a fair specimen of the Scottish peasantry.

I may instance also in proof of the compatibility of morality and a cotton-mill, the two great factories of Messrs. James Finlay and Co., the one at Catrine in Ayrshire, and the other at Deanstone in the county of Perth. In the former, there are about 900 operatives, all apparently happy and healthy, fully above the common lot of man. They have a chapel, a school, and comfortable dwelling-houses, much superior to those inhabited by the surrounding peasantry. The population of the village of Catrine amounts to 4253 persons; and though one-half of them subsist by factory labour, yet in the last twenty years the landed proprietors of the parish have been called on to pay only 212*l.* 14s. 1*d.* for the poor, which is little more than 10*l.* per annum.

The Deanston cotton-mill near Stirling, belonging to the same company, shows also the standard of health and conduct which may be maintained among factory workers by judicious management. There was no appearance of dirt or of impure air in the preparing or roving-rooms, when unexpectedly visited by the Factory Commissioners, Even in the web-dress-

ing-room of the power-loom department, a fan is most beneficially employed for drawing out the heat and moisture.

There are here apartments for the females to dress in, with a water-pipe in each story, and many other conveniences for the persons employed. Houses, with little garden grounds, have been built for such of the work-people as choose to reside near the mills, which are equally remarkable for the neatness of their construction and for their order and cleanness. The consequence of all these comforts is, that a more cheerful set of industrious men, women, and young people is seldom to be found. There are only forty spinners in an apartment eighty-two feet long and fifty-two broad, so that they have abundant space to move about their operations. The fans, revolving in large tubes, which draw up all the dust with considerable force, and keep the air of the room light, fresh, and agreeable, are worthy of remark, and are now adopted in most factories. See page 382.

So efficacious is religious discipline, steadily enforced by an enlightened master, to keep his dependents in the paths of virtue, that it may be laid down as a general rule—whenever mill-workers are noted for dissolute manners, the owner or manager will be found to be of licentious life, or at least indifferent to the welfare of the people committed to his care, who are ready to be influenced for good or evil by his precepts, regulations, and example. The following testimony places this position in a clear light:—“Some masters insist on better conduct, better dress, and more respectability. The overlookers are steady and suppress any thing bad. There is a great competition for ad-

mission into their factories. I have known thirty young women on the list at a time." What a tribute to virtue in the proprietor of a mill\*!

Like master like man, is a proverb no less applicable to public works, than to private families. The mill-owner who has a nice sense of purity in heart and life, a just comprehension of his own interests, and a conscientious concern for the well-being of his dependents, will adopt every practicable measure to raise the standard of their behaviour. If, on the other hand, he is lax in his own principles, and careless of their conduct, except as to their punctuality at their task, he will experience the consequences of this unconcern in slovenliness of work and in personal disrespect. Let us figure to ourselves a proprietor of extensive factories, a man of old experience, an unwearied worshipper of Mammon, and of course, a stranger to the self-denying graces of the Gospel. Such a man knows himself to be entitled to nothing but eye-service, and will therefore exercise the most irksome vigilance, but in vain, to prevent his being overreached by his operatives—the whole of whom, by natural instinct as it were, conspire against such a master. Whatever pains he may take, he can never command superior workmanship, he will find the character of his goods to be second-rate

\* What a contrast is exhibited between the female character in rural retreats, under the landed aristocracy, as depicted in the Poor Law Reports, and under the manufacturing aristocracy, as to be found on the crowded banks of the Irwell; the scene where two noble-minded proprietors have, in succession, made trade the handmaid of philanthropy—the late Sir Robert Peel and the present William Grant, Esq. Amongst the great numbers of factory operatives employed under this gentleman at Rumsbottom, only one case of female misconduct has occurred in the space of twenty years, and that was a farmer's daughter.

in the market, and he will of course get a second-rate price and set of customers. His whole business is blasted as it were by an evil eye. Aware of his unpopularity with his work-people, he strives to regain their favour by conniving at their vices, and views their intemperance on Saturday night and Sunday with indifference, provided it does not interfere with their labour on Monday morning.

Such policy may have been compatible with profit in times of narrow competition; but now it seldom fails, as I could prove by examples, to counteract prosperity at least, if not to impair the fortunes realized under better auspices. It is, therefore, excessively the interest of every mill-owner, to organize his moral machinery on equally sound principles with his mechanical, for otherwise he will never command the steady hands, watchful eyes, and prompt co-operation, essential to excellence of product. Improvident work-people are apt to be reckless, and dissolute ones to be diseased: thus both are ill-qualified to discharge the delicate labours of automatic industry, which is susceptible of many grades of imperfection without becoming so obviously defective as to render the work liable to a fine. There is, in fact, no case to which the Gospel truth, "Godliness is great gain," is more applicable than to the administration of an extensive factory.

The neglect of moral discipline may be readily detected in any establishment by a practised eye, in the disorder of the general system, the irregularities of the individual machines, the waste of time and material from the broken and pieced yarns. The master meanwhile may lose his temper on finding that his indulgence of the vices of his men is requited by indifference to his

interests; since he never doubts but that the payment of wages gives him a claim to their zealous services, however indifferent he may show himself to be to their vital interests. It is, therefore, as much for the advantage as it is the duty, of every factory proprietor, to observe, in reference to his operatives, the divine injunction of loving his neighbours as himself; for in so doing he will cause a new life to circulate through every vein of industry.

It appears that the artisans of the United States are treated on this principle, and they are accordingly declared to be more moral than the agricultural population. "At our establishment," says our authority, Mr. Kempton, "the proprietors (deeply sensible of the value of religious nurture) paid the greater part of the minister's salary after building a meeting-house; *and they frequently officiated themselves* at the evening meetings, which were well attended. We would not keep any workers that would drink spirits, nor did they at other establishments. Almost all of them belong to temperance societies. In the New England States, no man will get employment who is known to drink. In America, the employer is viewed rather as a tradesman to whom the work-people dispose of their labour, than as a person having a hostile interest. The manufacturers are always anxious that the children should be well educated, as they find them so much the more useful and trustworthy\*."

I hope the mother-country will not disdain to take a word of advice from her meritorious daughter, and that the mill-owners of Old England will study to discourage, by the effectual means above-mentioned, the

\* Committee on Manufactures, Commerce, and Shipping, p. 149.

sin of drunkenness, the peculiar opprobrium of our people both at home and abroad. "The English workmen in the American factories," adds Mr. Kempton, "are notorious for drunkenness and discontent. Their ignorant expectations generate ill-will and hostility towards the master, whence arise strikes, which grievously interfere with his commercial operations. For these reasons, they do not like to take English workmen in the New England factories. There are no jealousies between the American workmen and their employers, of the nature of those which appear to prevail between the English workman and his master."

The facilities afforded in a well-regulated factory for promoting the regeneration of human society may be inferred from the following interesting description of the state and dispositions of the operatives.

John Redman, one of the four visiting overseers of Manchester, superintendent of the Bennet-street Sunday-school, and for fifteen years treasurer of a sick society belonging to that school, had served during his early years in all the gradations of factory employment, at wages advancing from 1s. to 10s. per week. He was recommended to the notice of the Factory Commissioners by an advocate of the Short-time Bill, and may therefore be regarded as an unexceptionable witness, in respect to the moral capabilities of the factories. The following are extracts of his evidence given on oath.

"What is your opinion of the moral habits which are contracted by the girls and boys in the occupation you have just described?"

“ I would say first of all, that where they work at home they are shut up all day long with their parents, and have scarcely any acquaintance with others and with the feelings of their neighbours. The whole of the feelings which they thus imbibe may be selfish, and as their mode of working does not throw them out of the circle of their own house, or lead them to form any connexions with their neighbours, whatever connexions they *do* form arise from other circumstances than those of work ; but not half an hour passes in the factory, but what children are laying each other under obligations important to them. If one piecer finishes piecing up his ends before another, he runs to his neighbour to help him, and thus may save him a scolding or a blow, and he may be immediately indebted to his neighbour in return. This creates feelings of kindness ; and as spinners are continually changing their piecers, more or less, the latter are continually being brought into contact with strangers, and so these feelings extend wider. This interchange of kind offices is occurring all the day long, whenever the circumstances calling for it arise, and is observable in the assistance they give to one another when they are unwell. A piecer may be a little indisposed, and yet not like to stay away, and so lose a half or a quarter of a day ; then the others will help him in his work, and enable him to get his full wages. This is a common thing.”

When questioned as to the effect of factory employment on young females, he says, “ It is fathers or friends who work in factories, and they have all a common interest in checking immorality among the

younger assistants, both boys and girls. Suppose a cotton factory contains forty spinners, each of whom employs four piecers, making one hundred and sixty young persons of both sexes, and of ages varying from nine to twenty ; I should say that thirty, at least, out of the forty spinners, were married men, and that many of them had large families. Now even if none of their own children were working with them, yet they have all a common interest, as fathers, in discountenancing indecencies of conduct and language. Add to this that Sunday-schools have greatly increased during the last twenty years, and I should say, roughly, that there are upwards of 30,000 children who frequent Sunday-schools in Manchester alone. The teachers in them are generally adult young men and women, from the age of eighteen to about twenty-four or twenty-five. The female teachers will be working all the week as frame-tenters, stretchers, piecers, reelers, &c. ; and the male teachers also, as card-room hands, piecers, and, in some instances, spinners. Habits of decency, of order, of respect for religious observances, which they contract in their capacity as teachers, they naturally communicate, by precept and example, to their classes. I could give several instances of this. I wish to mention one which made an impression upon my mind.

“ One day, after the teaching was over at Bennet-street school, and there was, as there generally is, conversation among the teachers about the objects of the school, we were chatting together, and saying how desirable it was that young people should regulate their conduct out of the school in the same manner as they did in it, when one of the female teachers,

a young unmarried female of about twenty-four, who worked as a spinner at Mr. M'Connell's mill, said she had experienced much benefit from this, instancing it by saying that in the mill where she worked there were several young men who were known to be wild and rough, that they spoke improperly towards other young women, yet, knowing her situation in this school, and that she would not put up with it, they never spoke so to her; and that, besides, whenever she spoke to them about the impropriety of their conduct to others, it always produced the desired effect. I consider that such instances are not uncommon, and that they are extending among all the children that are educated at Sunday-schools, slowly perhaps, yet still going on."

The good effects of educating and training the infant poor are well exemplified in some of the factory villages. In the township of Turton, two miles from Egerton, already mentioned, there is a charity school in which ten or twelve boys are boarded and educated. This privilege has been enjoyed for nearly a century and a half. Henry Ashworth, Esq., proprietor of the cotton-mills of Turton and Egerton, states that he has heard it remarked, that during the recollection of the oldest officers and residents of the township, only two instances were known where the persons who had been educated under this privilege had received parochial relief. One of these never could learn his alphabet, and was, in fact, a kind of half idiot. In the other case relief was claimed only in extreme old age, and when the family of the pauper had deserted him. The children were all of the labouring classes, and were annually selected by the guardians of the poor. The

Messrs. Ashworth, deeply impressed with the above results, of training up children in the way they should go, have introduced into their establishments infant schools, under the care of young females of superior habits. In such seminaries they are sure that the children learn to be obedient and orderly, and to restrain their passions; and they are equally sure that, in a large proportion of cases, it is not so at their own homes. At two schools connected with their two works, and at another school supported by Messrs. Ashworth and others jointly, one hundred and fifty children, from three to nine years of age, have had for many years the benefits of education, with the happiest consequences. The mule-spinners, even the most rude and uneducated, and who do not make very nice distinctions, always prefer children who have been educated at an infant school, as they are most obedient and docile. Such children are bespoke beforehand by the workmen, who engage their own piecers. This is the most pointed way in which the effects of these infant-schools have appeared; and it is a most unequivocal proof of their usefulness, equally pleasing to the parents and the patrons. Other characteristics will doubtless be manifested as the children grow up.

It appears to me that those educational philanthropists who disdain to study the science of human nature, as it is expounded in the Gospel, have been running at fault, and spending their substance for a shadow. The first and great lesson—one inculcated equally by philosophy and religion—is that man must expect his chief happiness, not in the present, but in a future state of existence. He alone who acts on this principle will possess his mind in peace under every sublunary

vicissitude, and will not care to scramble with feverish envy or angry contention for the idol phantoms which the dupes of pleasure and ambition pursue. How speedily would the tumults which now agitate almost every class of society, in the several states of Christendom, subside, were that sublime doctrine cordially embraced as it ought to be! Without its powerful influence, the political economist may offer the clearest demonstrations of profit and loss, and the moralist may discourse most eloquently on the beauty, dignity, fitness, and utility of virtue, without furnishing restraints powerful enough to stem the torrents of passion and appetite which roll over the nations. The theologian also, who derives his knowledge of the Supreme mind from the deductions of physical or metaphysical science alone, may sermonize most ingeniously, but his voice will be impotent, like that of one crying in the wilderness. The *beau idéal* of religion, symbolized by the mitre and the crown, may be a grateful object of worship to the patrician; but it is too gaudy a pageant for fallen man, too replete with pride, to be compatible with a contrite devotional spirit. Vague notions, like the three just mentioned, cannot give birth to the heroism of faith, or to self-immolation, for the good of others. Pure acts of virtue must be inspired by the love of a transcendent Being, operating, through his counsels and example, on our will and affections. Sentimental theism has no moral force: it appears in the circles of fashion even as the companion and apologist of vice. Where then shall mankind find this transforming power?—in the cross of Christ. It is the sacrifice which removes the guilt of sin: it is the motive which

removes the love of sin: it mortifies sin by showing its turpitude to be indelible except by such an awful expiation; it atones for disobedience; it excites to obedience; it purchases strength for obedience; it makes obedience practicable; it makes it acceptable; it makes it in a manner unavoidable, for it constrains to it; it is, finally, not only the motive to obedience, but the pattern of it.

To these eternal truths what a triumphant testimony is borne in the history of the Prussian schools, as officially detailed by M. Cousin, a French philosopher, against whom neither credulity nor fanaticism can be alleged to weaken the impression of his statements.

“I know Europe pretty well, but I have never seen good schools for the people where Christian zeal was lacking. Elementary instruction flourishes in three countries; Holland, Germany, and Scotland, and in the whole of these it is essentially religious. The same holds true of the United States. In fact, there can be no truly popular education without morals—no morals for the people without religion; no religion without public worship. Christianity must form the basis of popular instruction, a truth which we must not hesitate to proclaim boldly to the French nation, for it is as sound in principle, as it is expedient for the state. Let our schools for the people be Christian in sincerity and zeal.

“Such silent self-devotion, as that of their masters\*, can be inspired and sustained by religion alone. When persons devote themselves to the service of their fellow men, without being known or appreciated, they must have their eyes fixed on Divine Providence. In these modest institutions every thing breathes a Christian

\* Masters of the obscure village schools in Prussia.

spirit, the love of one's neighbour, and regard to the poor. Under such a benign influence, minute regulations may be dispensed with; for the constant aim of the directors is to improve the heart and entertain the mind simultaneously. Let true Christian spirit pervade similar establishments in France; and it will excite masters and scholars to consecrate their labours to the children of the poor, out of love to their Saviour."

Here is poverty, to which the condition of our factory operatives is opulence; and the poverty is *hopeless*, for no idea is entertained of advancement or change. Yet if ever poverty appeared in man, serene, contented, lofty, graceful—it is here. Here we see individuals in the very spring time of life, so far from being made, as we are told men must be made,—restless, and envious, and discontented by instruction, taking indigence and obscurity to their hearts for life; raised above their poor neighbours in education only that they may become the servants of all, and that they may train the lowliest children in a keen sense of the high destination of man, of the beauty of creation, and in the love and worship of the all-good Creator.

Mrs. Austin, the able translator of M. Cousin's work, has introduced it to the English reader with a preface replete with eloquence rivalling that of the original. "I confess myself," says she, "almost hopeless of the transplantation of such sentiments hither. Religion is made the theme of the fiercest and most implacable contention; mixed up with newspaper squabbles, and with legal discussions; her bright and holy garments are seized and soiled by every angry and ambitious hand.

"It seems to me that we are guilty of great inconsistency as to the ends and objects of education. How industriously have not its most able and zealous champions been continually instilling into the minds of the people, that education is the way to advancement, that 'knowledge is power,' that a man cannot 'better himself' without some learning! And then we complain or fear that education will set them above their station, disgust them with labour, make them ambitious, envious, dissatisfied! We must reap as we sow; we set before their eyes objects the most tempting to the desires of uncultivated men, we urge them on to the acquirement of knowledge by holding out the hope that knowledge will enable them to grasp these objects:—if their minds are corrupted by the nature of the aim, and embittered by the failure which *must* be the lot of the mass, who is to blame?"

This thorough education of the people is not confined to the Protestant state of Prussia. It exists in remarkable vigour also in the Catholic dominions of Austria. Mr. Peter Kennedy, proprietor of a cotton-mill at Feldkirch, in the Tyrol, declares in his examination by the Factory Commissioners, that the Austrian law requires all children to attend school till they can read and write to the satisfaction of the parish priest. If he discovered that a child was not sent to school, but sent to the factory to work for its parents, as happens daily in Manchester and Glasgow, he would remonstrate with the parents, and in case of contumacy would cite them before the judge, who would compel obedience by imprisonment or other means. "I do not know," adds he, "that we have any workmen who cannot read and write."

The proud spirit of the English people would render any attempt at compulsory education among them abortive. But social benevolence is now busy endeavouring to make up for the defective instruction provided by the state.

The ministers of the gospel of every denomination in the factory districts seem thoroughly alive to a sense of their sacred responsibilities, display a missionary spirit worthy of the first ages of Christianity, and exercise their regenerating functions with zeal, not only in the pulpit, but in the recesses of sin and suffering. It has been alleged, that the long denial of political rights to the factory metropolis, and the independence of its established clergy on public opinion, had alienated many of its most influential citizens from the church, and had even to a certain extent chilled the ardour of their faith. However this may be, I believe, from what I have witnessed there, that religious sentiment lingers no more in the frigid aphelion of neologism, but is advancing towards the true source of moral light and heat—the Sun of Righteousness, never again, it is hoped, to fly off in that excentric orbit. This happy change must be ascribed, under the blessing of Providence, to the vast circulation of the Scriptures, and increase of Sunday-schools, the two most glorious features of our times.

Animated with a moral population, our factories will flourish in expanding fruitfulness; for they possess deeper and more extensive roots than is commonly conceived, even by many of the manufacturers themselves; a fact which, if well considered, should prevent all despondent misgivings. Indeed, I met with only a few individuals who feared foreign competition,

and these were gentlemen little versant in mechanical science, and of narrow views in political economy. The more intelligent were ready to confide in their intrinsic superiority, provided they were not again invaded by an inquisitorial crusade, an event not at all likely after the results of the late able government commission become generally known.



## BOOK THE FOURTH.

*Commercial Economy of the Factory System.*

SEVERAL of the observations originally written for this section of the volume having, in its progress through the press, been incorporated with the descriptive portion of Book II. and Chap. I. of Book III., for the purpose of illustrating certain details of the cotton, wool, and silk manufactures, I shall now confine myself to a few general remarks on the present condition of commerce, capital, and credit; and on the influence of free and restricted trade on the industry of nations.

The character of our manufactures has changed much for the better of late years.

Formerly there were large quantities of merchandise manufactured, and kept on hand to wait the chance of a market; that is not the case now; the manufacturers take orders, and these orders seem to employ them fully. To show the correctness of this remark, one of the greatest houses in the world, that of Messrs. Baring, were not long ago under the necessity of making contracts in April or May, for goods deliverable next September. Mr. Bates, of that firm, informs us that when he first came to this country twenty years ago, there were in many warehouses in London 20,000, 30,000, 50,000, and even 100,000 pieces of Manchester goods for sale; but now, when he receives, in the common course of his business, a commission

for a large quantity of goods for the American market, he is obliged to order them a considerable time before. The stuffs, whether woollen, linen, or cotton, have also improved very generally in quality. "The old-hand workmen," says a woollen manufacturer, "are certainly not well off, for the young ones understand the business so much better, that they are employed in preference; they do their work with much more skill\*."

In proof of this position, Mr. Bates states, that two French gentlemen had recently arrived with very extensive orders for British cloths, which he considers a singular circumstance. They were purchasing for a foreign market, and observed that a much handsomer cloth was made in England than could be made on the Continent of the same materials, a circumstance which induced them to come here to purchase.

The increased demand for our goods is not partial or temporary. It has proceeded from all parts of the world pretty equally, independently of the augmented home consumption. The advices from the different regions of the globe, from the coast of the Pacific, from the Brazils, and from Mexico, indicate the improving condition of those countries, and consequently an extended demand for all descriptions of manufactures. A very considerable increase is about to follow the opening of the trade to China. "The United States," adds Mr. Bates, himself a citizen, "will probably in due time get rid entirely of their tariff, except so much as will serve to supply the little revenue they want, and that will open a new demand. Then there are the immense

\* Committee on Manufactures, 1833, p. 47.

Colonies which are peopled from this country, growing into importance every year, furnishing an increased demand, the magnitude of which it is impossible now to measure. One obvious cause of the extension of trade, is the great fall in the price of cotton, owing to the fall in the price of slaves, and the productiveness of the plantations in the valley of the Mississippi, where cotton-wool can be raised with a profit at 3*d.* per lb., and as the prices have been much above that, the cultivation has gone on extending at a rapid rate.

The linen manufacture has of late years begun to rival the cotton in its rate of development. Mr. Marshall of Leeds says, "that our increased facilities of spinning flax in factories should abate the apprehension of foreign rivalry and enable us to compete more effectually abroad in neutral markets." But he subjoins, "our export trade is restricted, in consequence of the corn laws preventing returns being made in articles which we consume\*." On this point, few people are aware of the relative positions in which our manufacturing interest and our landed interest are practically placed towards each other, by reason of the different proportions which the gross quantities of their respective productions bear to the consumption of the country; and consequently few persons perceive the degree in which this natural inequality of advantages is aggravated by the interposition of a law which throws its weight to that side already preponderating.

If any interference between these two interests could be justified, a far better case could be made out in favour of a bounty to increase the importation of corn than of a duty to restrain it; for the agriculturists

\* Committee's Report on Manufactures, &c. 1833.

have, under any circumstances, the great advantage of always selling their goods at home in a market inadequately supplied; whereas the manufacturer, when he sells at home, sells in a glutted market: propositions deducible from the official accounts of our imports and exports.

The average annual quantity of foreign corn, chiefly wheat, imported into England during the last seven years, was very nearly two million quarters; besides large quantities of seeds, butter, and cheese. One-third, at least, of all the tallow we use comes from abroad; and oils are largely imported as a substitute for tallow in making soap; as also fish oils, to be used for lamps instead of candles. This list of agricultural produce, or its substitutes, might be considerably extended, without including any thing which is not suitable to our soil and climate; but it is sufficient for the purpose of showing that the landholder has, for the product of his fields, the advantage of a home-market in which the demand is much greater than the supply.

The amount in real (not official) value of British manufactures exported in each of the two last years was rather more than 36,000,000*l.* and nearly the whole of this sum is constituted of labour. Cotton, fine sheep's wool, flax, and dyeing drugs are the chief of those raw materials of our exports which we do not produce; the metals and the coals are in our mines till labour extracts them. Making, therefore, ample abatement for foreign materials, the quantity of surplus labour in the country, that which must seek a foreign market, may be roundly estimated at 30,000,000*l.* sterling a year, (see page 440). The

home-market of the manufacturer, therefore, is always a glutted market.

For the sake of perspicuity, let us personify the argument. A landowner has 100 quarters of wheat to sell, the whole of which and more are wanted by the manufacturer. The manufacturer has 200 pieces of cotton goods to sell, half only of which is wanted by the landowner. As the quantity of the one is deficient, and the quantity of the other is excessive, in their common home-market, the prices of both must be governed by the foreign market, the influence of which upon them will be manifested by inverse consequences; the one being in the reverse predicament of the other. The question between them can be fairly tried only under the assumption of a state of perfect freedom of trade to both.

When the landlord is seller, he is enabled, in fixing the price on his wheat, to add to the amount of the foreign price, all the expense which must be incurred in bringing wheat from abroad. He stands firm in the market, and says to the manufacturer, "Reject my wheat if you please, and go a thousand miles by water and by land to fetch the cheap wheat you speak of."

But when the landlord, changing his position, becomes the buyer of his neighbour the manufacturer's cottons, he reverses his arithmetical formula, and he deducts from the price they would fetch in the foreign market the whole expenses of sending them thither. Nor is his language less changed, though it is equally peremptory. He now says to the manufacturer, "There is my offer, leave it if you like, and carry your goods half round the world, in quest of that better price which you flatter yourself to receive in other countries."

Whether as buyer of the wheat, or as seller of the cottons, the manufacturer submits to the dictation of the landowner; for it is he, and not the landowner, who is in both cases subject to the control of the foreign prices; and the result is, that he gives 100 pieces of cottons for fifty quarters of wheat. But this is only half the story, and affords a very inadequate representation of the natural advantage which the landowner has over the manufacturer, and of the consequent injustice of increasing that advantage by artificial means.

We have seen that the first use which the landowner makes of his power over the manufacturer, is to supply himself with home commodities to his heart's content, in exchange for a moderate quantity of his corn. He has got, for instance, 100 pieces of the cottons for fifty of his 100 quarters of wheat; and now feeling himself still rich with fifty quarters more at his command, a desire comes over him for the enjoyment of foreign luxuries, along with his home-grown comforts, and he studies to make his remaining stock of wheat available for procuring them at the easiest rate. But when he contemplates sending this wheat to the foreign market, the reflection immediately occurs that he must submit not only to take the foreign price for it, but to deduct from that price the charges of exportation, instead of being able to add the charges of importation, as he had done in his hard bargain with the manufacturer, on the first fifty quarters which he sold him. Now, therefore, he says to himself, I remember that the manufacturer of whom I bought my 100 pieces of cotton had another 100 lying heavy on his hand, and I well knew that he was sorely in

want of more wheat than the fifty quarters which I sold him. I will carry to him the residue of my wheat, and offer it for the residue of his cottons. In his double distress, with glut on the one side, and deficiency on the other, he will gladly come into my terms; and then I shall get a description of goods which I can make use of, as an advantageous medium for the acquirement of the foreign commodities, silk, teas, pictures, &c. which I am so desirous of obtaining.

This is the true working of sale and purchase in a home-market, where different staple commodities are produced in very unequal quantities; and it should satisfy the fortunate party with his natural advantages. But the English agriculturists have, unluckily for themselves and their country, the power of regulating their own corn laws, and have sought to increase these advantages by imposing duties and restraints on the importation of foreign corn. And although the scheme has signally failed to assure to them the prices they expected, or even the prices they would have had, if they had wisely suffered commerce to follow its own lead, it has, nevertheless, enabled them to exchange quantities of their corn for large quantities of home manufactures, which they employ partly for their immediate consumption, and partly to exchange again for foreign commodities, in the manner above described.

A rightly-intentioned land proprietor, if he could be brought to perceive the relative positions in which the agricultural and manufacturing interests are placed, would be anxious to denounce the system as one of subtle and severe oppression. For it does not permit the manufacturer to send his goods to the

destined foreign market on his own account, nor to receive in return for them the description of foreign goods, namely corn, which he wants for himself. The land-owner is thus virtually both exporter and importer; for by the operation of the corn act, he has a right of pre-emption of his neighbour's wares at a maximum price of his own fixing. The magnitude of the exports proves that *their* influence over the whole industry of the country must be overpowering. While the corn act lasts, the landed interest have, in fact, the power of dictating prices both as seller and buyer. But justice requires that all buyers and all sellers be placed on an equal footing\*.

This expiring act of feudal despotism enables the landlord not only to extort the products of his neighbour's industry, for much less corn than they are worth in the market of the world, but to mulct him severely in the process of manufacture. Mr. W. Graham states, that in his own establishment at Glasgow, in which from eighty to ninety bags of cotton of 300 lbs. weight each are worked up weekly, he pays in duty on flour nearly 700*l.* per annum. Into each piece of his white calicoes about twenty pounds of cotton wool enter, and three pounds of flour for dressing the warp.

We may estimate that every power-loom causes a weekly consumption of three pounds of fine flour. Now as there are at present not less than 100,000 power-looms in operation, the total flour consumed by them per annum will be  $3 \times 52 \times 100,000 = 15,600,000$  pounds, which divided by 280 will give 55,714 loads. This quotient multiplied by two guineas will show the

\* See this subject fully expounded in H. B. T.'s *Letters on the Corn Laws*.

cost of that weight to be 117,000*l.* Now suppose the corn laws raise the price of flour 10*s.* per load, the power-loom manufacturers pay an annual tribute to the landowners of 27,857*l.*; or a tax of 5*s.* 6½*d.* upon each of their looms. In what respect does this exaction differ from feudal villenage except in the polite, or rather oblique, manner of levying the service? The *fortiter in re* remains, under an apparent *suaviter in modo*. The industrious *villains* are now fortunately released from the precariousness of employment under their ancient lords, thus quaintly expressed by the chronicler Braton: *sciri non poterit vespere quale servitium fieri debet mane*\*.

A fair evidence of commercial prosperity, in spite of the corn act, is afforded by remarkably few failures, a very great number of bills of exchange, rather small in their character, yet the aggregate well kept up, coupled at the same time with great supplies of money from almost every part of the kingdom, by the great regularity with which bills are paid, and by the manufacturer in credit readily getting accommodation. If a man has the character of a good tradesman, is conducting his business well and with prudence, he has no difficulty in finding the requisite means upon his own credit. The capital of the commercial world is more diffused than it was formerly; and every branch of trade is now carried on by persons possessed of capital of their own. Formerly it was extremely difficult to get capital to carry on any business, whether trading, commercial, or manufacturing, but at this time there is no difficulty, provided the parties have a

\* He never knows at night what service will be required of him in the morning.

good concern to render that advance prudent. There is now a reduction of profit indeed, but there is also a reduction of risk; such reduction of profit arises from the great mass of individuals possessing trading intelligence and moderate capitals, and is the result of the health and general well doing of the country. The years 1824 and 1825 gave much salutary experience.

But capital alone is not worthy of credit, unless associated with moral qualities in the tradesman; for a prudent man of great industry, integrity, and knowledge in his business is more worthy of credit without capital, than a rich man ignorant of his business. Population has increased one-third in the last twenty years, and the home trade fully in proportion, though it is now carried on with much less expense than formerly. Persons who begin with large capitals do not succeed, generally speaking, so well as those who begin with small ones cautiously administered.

The manufacturer himself now supersedes almost every middle man, and goes directly to the importer; that is, he studies to lay in his materials at the cheapest possible rate, in order that he may make his trade answer with the present smallness of profit.

The first symptom of an unprosperous trade is the irregularity of the payments of the persons in it, a symptom not much observed by the bankers for some years back. The quantity of business has been increased to make up for the decrease of profits; but the same trade may be now carried on with half the amount of capital\*.

From 1820 to 1823 the average annual value of the imports of foreign merchandize into the United

\* Committee on Commerce, Manufactures, and Shipping, 1833.

Kingdom was . . . . £32,381,000  
 in 1831 it was . . . . 49,713,000  
 being an increase of more than fifty per cent. Of that increase about seven millions were materials of our manufactures, and little more than half a million were manufactured articles, being chiefly silk goods.

The exports for the first of the above three years were annually worth . . . . £42,950,000  
 and for the last year . . . . 60,912,000  
 being an increase of nearly eighteen millions, or full forty per cent. :

Consisting of Cotton Goods . . . .	£14,536,000
„ Linen . . . .	0,864,000
„ Woollen . . . .	0,208,000
„ Metal . . . .	1,600,000
„ Sundry Manufactures . . . .	0,784,000
	£17,992,000

Under the improved system of trade introduced by Mr. Huskisson, and since extended by his successors in office, a progressively increasing quantity of the produce of British industry has been exported to foreign countries. Thus in

	1833.	1834.
Cotton Manufactures ; } declared value	£13,782,377	£15,306,922
Cotton Yarn . . . .	4,704,024	5,205,501
Linen Manufactures . .	2,239,030	2,605,837
Silk Manufactures . . .	0,737,404	636,419
Woollen Manufactures . .	6,540,636	5,975,657
	£28,003,471	£29,730,336
Total exports of nine } Principal Articles }	£34,489,384	£36,541,926

Hence we see that the textile manufactures constitute at present about ten-twelfths of the whole exports of the United Kingdom ; and of these, seven-twelfths are cotton goods.

The soundness as well as the elastic spirit of our manufactures may be inferred from the following statement of Mr. K. Finlay to a Committee of the House of Commons, in May, 1833 :—“ I think that if 50,000*l.* had been laid out well by judicious parties who manage their business properly, ten years ago, it would, long since, have returned that 50,000*l.*, and perhaps another 50,000*l.* also; and that, therefore, if the persons had exercised due economy, they would now be in possession of their cotton-mill for nothing. I consider that for the last two years there is a great diminution in the profit, and I trust it is a temporary diminution. I have seen a great many overthrows in the cotton manufacture : in 1788 I thought it was never to recover ; in 1793 it got another blow ; in 1799 it got a severe blow ; and in 1803 again, and in 1810. At particular periods, one would have thought that it was never to extend again ; but at every time that it received a blow, the rebound was quite wonderful.”

Mr. Marshall, of Leeds, states, in his evidence to the Committee on Manufactures, that the linen trade of England has been doubled, and that of Scotland trebled, since he was first connected with the business, forty-five years ago. The flax-spinning, his particular branch, has been very prosperous of late years, owing to the great improvements in spinning machinery ; prior to which the French and Belgian hand-spinners were so much more expert than those of

the United Kingdom, as to secure to Flanders, and the north of Europe, the chief manufacture and source of supply of superior linens. Mr. Marshall, in 1833, employed twelve hundred and twenty-nine hands in spinning, and from seventy to eighty mechanics, in his establishment—all at average good wages. He spins about one-fourth of the whole quantity spun in Leeds. He has re-constructed his machinery twice since he has been in business.

The fall in the price of the raw material, joined to the improvements in machinery, is the cause of the lowered price of the manufactured article.

There has been, at the same time, no falling off in the quantity of linens manufactured in Ireland; but, on the contrary, an increase, from the introduction of mill-spun yarn, which has given the Irish linen a preference over the continental linens.

The women spinners, thrown out of work, have got employment in the weaving department.

The proprietor of a small mill cannot manufacture as cheaply as the proprietor of a large one, because he has not the same means of making arrangements on a proper scale.

The rate of profit is often in proportion to the magnitude of a business. A partner of a great silk house in London mentions the case of a friend who, after starting in trade, on an advance of 20,000*l.*, found that on that scale he could make only six per cent.; but saw clearly that if his means were doubled he could introduce such savings in his business as would yield him a profit of nine per cent. It is these savings that induce the cotton manufacturer to operate on the large scale, and to make occasional sacrifices on small

parts of his stock, in order to carry or to secure a profitable result on the whole. It is to this circumstance England owes her superiority: it is because her capital is larger than the capital of any other country, that she is able to introduce greater savings; and occasional over-production is one of the evils consequent upon it. Thus it is the practice of many manufacturers, in consequence of the advantage of operating on a large scale, to manufacture beyond the amount of the orders they have received, and to export the surplus, at a price which keeps down foreign competition. The profits on the greater proportion indemnify them for the losses on the smaller. This cannot be called an act of speculation, but of necessity. The excess must be exported, or the system of operating on the great scale must be abandoned.

It is for the permanent interest of manufacturers to sell for a small profit, and it is, on the other hand, a short-sighted policy to seek for a large one; the knowledge, or even the rumour of which never fails to bring a great many persons into the trade, with the effect of entailing a ruinous depreciation of the goods. The smallness of a profit stimulates to diligence, economy, and discretion; for a factory well conducted may be very lucrative with a moderate capital frequently turned.

When the wisdom of our ancestors was in the habit of interfering with the business of individuals, Parliaments had passed various restrictions on the linen trade of Scotland. An act of the 13th of George I. affords a remarkable instance of the folly of such legislation. It contained no fewer than forty sections, regulating not only the bulk of the thread to be used, but the length, breadth, and shape of the cloth to

be manufactured. Table linen, for example, was to be made square, and to contain so many threads, and no more, in a specified width. How this absurd regulation came to be made we cannot easily imagine. We may understand why cloth should not be allowed to be too narrow, but why good cloth should be restricted to a certain width, when a broader article might be often wanted, is a secret buried with the sapient fathers of the law. A great many other statutes upon the same subject had been passed, issuing out of the confusion and inconvenience arising from the first. Mr. Huskisson had the merit of doing away with them altogether by his bill on the Scotch linen manufacture, passed in April, 1823. Since this business has had its fetters struck off, it has grown to a magnitude almost without a parallel in any branch of trade.

Till 1830, no less a sum than 300,000*l.* was expended annually, in bounties, on making and exporting Irish linens, being one-seventh of their total value,—a monstrous abuse, which made the manufacturers careless about improving their fabrics, or even about the management and economy of their trade, and therefore not generally prosperous, but occupied solely in supplying foreigners with cheaper linens than could be honestly made, and all for the vain glory, as it was at the expense, of the British revenue. No wonder that the nations of the Continent believed the English to labour under a pecuniary plethora, and that they played every species of extravagance to get rid of it.

During the year 1825, 35,993,038 yards of British linen, worth 1,309,616*l.*, and 16,087,176 yards of Irish linen, worth 918,385*l.* were exported from the United Kingdom; amounting together to 52,080,184 yards,

worth 2,280,001*l.* The bounties paid during the same year on these two quantities of linen, were 209,516*l.* + 84,549*l.* = 297,065*l.* It appears that the bounty formed no less than one-tenth of the price of these Irish exports; and as the imports of linen into Great Britain from Ireland were nearly of equal value with the total exports from the United Kingdom, it further appears that the total bounty was a bonus paid by this island to her dear sister.

Scotland manufactured and stamped for exportation, in the year 1820, 36,268,530 yards of linen, worth 1,396,295*l.* The linen intended for home consumption was not stamped, and must be added to the above. Dundee, by the adoption of improved machinery, has increased its linen manufactures in a wonderful manner—from a consumption of 3000 tons in 1814, to 15,000 tons in 1830. In the year 1831 it shipped off 50,000,000 yards of linen, about 3,500,000 yards of sail-cloth, and nearly 4,000,000 yards of bagging; being about 57,000,000 yards in all. These shipments had increased about one-sixth in the year 1833, amounting, in value, to 1,600,000*l.*; and being as great, from this single Scottish port, as from the whole of Ireland.

The linen manufacture of the kingdom may be now valued at eight millions sterling, of which it distributes fully three millions in wages, employing about 180,000 hands, young and old. The consumption of foreign linens in this country is inconsiderable, being, probably, under 20,000*l.* In 1833 there were retained, for home consumption, 1,127,736 cwt. of flax and tow, or codilla of hemp and flax; and 537,890 cwt. of undressed hemp. The value of imports of raw materials would be about two millions and a half



of pounds sterling; and of exports of linen, nearly as much, besides the export of linen yarn.

It has been well observed, that the progress of improvement in manufactures and the fine arts is the same in principle \*. An inferior sculptor, who had got possession of the English market, would regret to see the works of Canova, or of his expert Italian scholars, come into competition with his own; but in this regret the people of this country could not sympathize. Every one desirous of promoting the diffusion of a better taste in England would be glad to encourage the importation of the productions of the Roman and Florentine chisel. Now there is no distinction in reality between the measures to be taken for the cultivation of one species of industry more than another. Present, in all cases, the best models for imitative emulation, and you ensure the progress of improvement. In every country there is more or less dormant labour and faculty of invention. The great object of all commercial legislation should be to call these means of wealth and comfort into action by every reasonable excitement; and, above all, by admitting the raw materials of the arts from their indigenous countries exempt from duty, or impediment of any kind. Even manufactures should not be excluded by a high tax, but subjected simply to such a moderate duty as may merely balance the particular facilities of the district where they are made, and furnish a custom-house revenue to the state. In fact, foreign competition should always be permitted to urge on, like an impelling spring, the movements of our own industry, but not to press too suddenly on the more delicate parts of the machinery, till its

\* Dr. Bowring, M.P., in *Silk Trade Report* of 1832.

adjustments have been allowed a moderate time to settle themselves. It may be laid down as an axiom, however, that the trade which cannot learn soon to stand on its own legs at home, will never be able to go abroad into the world, with all the patronage of the state.

Free trade consists in the entire absence of restrictions of any kind on the export and import of merchandize. Constrained trade has, for one of its principles, to encourage the productions and manufactures of our own country, by imposing taxes or prohibitions on those of other countries; and for another principle, to prohibit the exportation of such of our native productions as might be beneficial or essential to a rival foreign manufacture. Besides removing as much as possible all competition from native industry, legislatures, on many occasions, undertook to cherish it by bounties on exportation, in order to enable the manufacturer or shipper to sell his goods at a cheap rate. This system was necessarily very complex, being entangled with numberless springs and counterchecks. Its working was well illustrated in the case of wool, the exportation of which, especially the long stapled kind, was not permitted, because it would raise the price to the home artisan, and supply the foreigner with an indispensable material; and all this in opposition to the interest of the grower, whose gains would rise with the extent of his market. Moreover, the encouragement of one manufacture was thought to be injurious to others: that of wool, for example, to the cotton, silk, and linen trades. The muslin manufacturer deprecates the exportation of cotton twist, and solicits a restrictive duty upon it; which the spinner

declares to be absurd and iniquitous. The silk weaver wishes to import thrown silk only, but he is resisted by the silk throwster, who, in his turn, claims a protective duty on the importation of thrown silk, however injurious to the weaver. No arrangement of human sagacity, separately or collectively exercised, could adjust all the interests placed in collision by that false principle. Individual, as well as public justice, requires that trade be left free and unembarrassed, unless special reasons can be given for putting it in bondage; just as it requires that every man should enjoy perfect liberty of person, till his liberty be proved to be dangerous to others. Every man should be allowed to buy, to sell, and to manufacture in any way, and whatsoever articles he chooses, and to transport them whithersoever he shall desire; and any law which interferes, either by prohibition or regulation, with his business, is, until shown to be necessary for some legitimate purpose of public revenue, an act of oppression. When a duty is imposed on an article of native production, as spirits, for the purpose of revenue, a corresponding duty must, in justice, be laid on the same article imported from abroad; but this is merely a fiscal compensation, independent of the principles of free trade\*.

The general principle of trade is, to sell, in order to buy. We may open our ports to the silks and wines of France, to the corn of Germany and Russia, to the drugs of Asia and of India, but we cannot get a pound's worth of any commodity without giving in return a pound's worth of our own productions. Our manufacturers will give away nothing; they will not send their goods to foreign parts without getting an equiva-

\* See Speeches of the Right Hon. W. Huskisson.

lent in return; and the producers of foreign commodities, French, Germans, Russians, are as little likely to make a present to the British consumer of their hardly-earned produce without taking in return the well-earned produce of this country. If foreign nations meet our liberal policy by tightening still more their restrictive system, they will merely limit their own export trade, and curtail their own commerce to the injury of their people. If, by some potent spell, the nations of the continent could surround their dominions with the wall of brass imagined by Bishop Berkeley, if they could effectually exclude every article of British produce, whilst they opened their ports to give free egress to their own, they would not be able to introduce a single vessel into our ports, or if they did, they must make us a present of its cargo. They would deprive their own subjects of the benefit of mutual interchange—they would deprive us likewise of it, but they could do no more; they would impoverish and ruin their own country; they would injure us in a less degree; they would reduce us, no doubt, to an unhappy condition, the necessity of producing all we want within ourselves, the Utopia of the restrictive theorists.

Fortunately, no government has the power of carrying into effect so pernicious a principle. There is in economical as in physical compression, a point of resistance endowed with irresistible energy, where legislation becomes powerless. Governments may, indeed, enact absurd laws, but they cannot compel mankind to obey them. In the present case, the smuggler becomes the corrector of faulty legislation, and the vindicator of human rights. Through his agency acts of parliament are nullified, and the vigilance of custom-houses is

eluded. What a striking proof of this equating principle has Europe lately seen! The man whose commanding influence was never surpassed in modern, and seldom equalled in ancient times, even Napoleon, when in the zenith of his power, fulminated his decrees from Milan and Berlin against international commerce in vain. The mighty chief whose armies enthralled in succession every capital of continental Europe, who raised up and threw down kings with a breath of his mouth, was set at nought by the feeblest of his subjects. The smuggler triumphed over him in the heart of his empire, and defeated his myrmidons of *gendarmes* and *douaniers*. The goods against which he erected stupendous dams found their way through innumerable channels to the palace of his pride. It is well known that an uninterrupted line of communication was established between Archangel in the Frozen Ocean, and the capital of France, by which the bulkiest articles of commerce, cotton goods, sugars, coffees, were conveyed with as much certainty, under a stipulated per centage, as from London to Dover. Insurances upon their safe delivery at the destined goal were easily effected at Brody and Leipsic, in contempt of the tyrant's denunciations\*.

But the silk trade now exhibits the best illustration of the compensating principle. Italy, which furnishes us annually with raw and thrown silk to the value of upwards of two millions sterling, refuses to open her ports to our manufactures in return. How do we then repay her, since her custom-houses reject the equivalent debt in barter? Upon a careful examination, it appears that the bills which are drawn from Italy for

\* Right Hon. C. P. Thompson. Speech on the Silk Trade, 14th April, 1829.

payment of this silk, by several houses in the trade, are, to the amount of at least three-fourths, remittances from the Austrian and other German states made to Manchester and Glasgow for their cotton manufactures. Thus we see how impossible it is for any government to resist the desires which their own people have, to possess reciprocally the productions of another nation. It may injure its own subjects by enhancing the price of the commodities they need, but it cannot deprive them of their enjoyment.

The advantage of the country which is the first to adopt free trade is not merely conditional, but absolute. Under our old system of restriction, other nations could arrange and maintain equivalent restrictions; but under a system of free intercourse, they may indeed apply shackles to trade, but they cannot bind them fast. They may strive for a time to humour the wishes of the interested producers, and their dupes in their own country, but they cannot carry on the delusion long. The ruin of their own manufactures, the impoverishment of all those not directly enriched by the monopoly, and the remonstrances of the great mass of consumers, will, ere long, compel their government to adopt a wiser and a juster course. If we wait till a foreign state grant reciprocity, we are the slaves of their prejudices; if we give free admission to their produce, we become in so much their masters. What is the mercantile condition of France at the present moment? What profit does it derive from the illiberal policy which now guides, and will probably continue for some time to guide the councils of that kingdom? She manufactures cotton goods and raises iron at a far greater cost than she could get them from

us; and in doing so, she plumes herself on her patriotism. But what effect has that system of forced production on the national well-being? What do those classes of producers think of this system, when they find that there is no longer an adequate demand for their own goods? Are they, or should they be satisfied? No, truly; for they have discovered to their cost, that other nations will not and cannot buy *their* produce, when they, by means of their fiscal laws, refuse to take barter in return. Multitudes of the suffering wine-growers and others, having had their eyes now painfully opened, call upon the Chambers in the strongest language to renounce the restrictive system, and to adopt another more propitious to their interests. These wine-growers involve an interest five times greater than any other class within the French territories, employing three millions of people, and a capital ten times the amount of what is embarked in any other business of the country. "What," say they, "is the basis of the prohibitive system? It is the chimera of selling without buying. A mystery still to be unfolded. If we shut our ports to the productions of other nations, it is good for us at least to be aware that their ports must be sealed against our industry; for this reciprocity is inevitable in the nature of things, and what are its results? The destruction of the means of interchange, the suppression of all emulation for improvement, and the obtaining a worse article at a dearer cost." This sound doctrine is supported by infallible proofs; by official documents, showing that the *decrease* in the exportation of wines from Bordeaux and other places has amounted to from 100,000 to 300,000 hogsheads. In fact, the French must sooner

or later follow our footsteps in the career of free trade. A restrictive system cannot, in this age of the world, be upheld by the power of governments, nor be suffered by the interests of their people.

In pursuing a gradually progressive but steady approach to a liberal system, we must tamper as little as possible with manufacturing or commercial industry by legislative regulation. Like love, its workings must be free as air; for at sight of human ties, it will spread the light wings of capital and fly away from bondage. By loosening the bands in which the unwise tenderness of our old legislators had swaddled the trade of great Britain, by letting it run wherever it may list, by exposing it freely to the breezes of competition, we have within a few years given it fresh vigour and a new life. National industry has the same principle of vigorous growth as the mountain pine. Self-sown in the clefts of the rocks, it creates a soil for its roots, shoots up a hardy stem, is invigorated by the gale which would blast the nursery plant, eventually rears its head on high, and forms a mast for some "tall admiral." Planted in the rich compost of a parterre, having its infant shoots nursed in the close atmosphere of a forcing glass, protected from extremes of heat, moisture, and drought by a watchful gardener, it remains feeble, dwarfish, and sickly, and never can become a mass of timber profitable to its owner, or useful to the state. The elements of industry may be expressed in one word—competition\*. Never was a better advice given to a monarch too ambitious of the glory of patronage, when he asked what he could do to promote trade. "Let it take its own course,"

\* Right Hon. C. P. Thomson, *ut supra*.

was the memorable reply. This adage ought to be engraved on the portals of every legislative assembly of the old world and the new.

Since liberal principles have begun to prevail in the councils of Britain, they have given a wonderful development to the talent, the genius, the enterprize, the capital, the industry of the nation; they have pushed on its manufactures with an accelerated impulse among those of rival states, and have placed them on such a vantage-ground, as nothing but moral disorders from want of right education among the people can subvert.

It was in 1824 that Mr. Huskisson introduced the principle of free trade into our silk manufacture. He reduced the duty on thrown silk from 14*s.* 7½*d.* to 7*s.* 6*d.*, and the duty on raw silks from 3*s.* to 1*d.* per lib. In 1825 the duty on thrown silk was reduced from 7*s.* 6*d.* to 5*s.* per lib., the last change being effected by a Treasury order; as it was the intention of Mr. H. to impose an *ad valorem* duty of 30 per cent. on foreign goods imported into this country. In 1826 the new President of the Board of Trade substituted for the latter plan a graduated scale of duties regulated by weight, by pieces, &c., the basis of which was 30 per cent. In April 14, 1829, during a period of depression in business, a motion was made in the House of Commons for enquiring into the state of the silk trade. Mr. Huskisson and Mr. C. P. Thomson argued that the law on the subject was not in fault, and endeavoured to show that the weavers themselves were to blame. Although their "book price," as it was called, had been repealed, some parts of that system were still retained. A London manufacturer

sent for two operatives to Spitalfields when the distress was most talked of, and offered them 7*d.* a yard for weaving a quantity of serge. The proposal being laid before their union-committee was rejected. The manufacturer got the work forthwith done in Essex for 5*d.* a yard. As to the throwster, the operation of the new law had been to extend greatly his business.

In 1821 the proportion of Italian thrown silk to Italian raw silk was 56½ per cent.; in 1822 it was 59 per cent.; in 1823, 55 per cent.; in 1827, two years after the operation of the law, it was 35 per cent.; and in 1828, when the law had become active, it was only 25 per cent. Improvements in machinery, which had rendered the old mills of little value, had a considerable share in the present distress. Another cause was the smallness of capital among the throwsters, which incapacitated them from supplying themselves with the raw material on good terms, and rendered them the jobbers of the brokers. No throwster who had adopted improved machinery appeared to have suffered; but many of them, on the contrary, had been very prosperous. Even if all duty were removed from thrown silk, the weaver to whom it served as a raw material would be benefitted. It has been said that the fine silk of Italy could be thrown to the best advantage only in that country, owing to the peculiarity of its climate; and that the coarser silks were better suited to the throwsters of Great Britain\*.

From 1823 to 1828 there was an increase in raw and thrown silk amounting to 90 per cent. Under the restrictive system, the weavers of Spitalfields were exposed every three years to a season of distress. In the year 1817 40,000*l.* were subscribed for their relief; and 40,000

\* See this subject discussed, p. 248.

persons were said to be in want. The absurd act of parliament which regulated wages, had driven capital from Spitalfields, and yet it was sought to be restored by the deluded operatives of that district. Were such an act extended throughout the kingdom, it would drive every manufacturer out of it.

If it were possible, says a great master of commercial economy, to make a calculation of the quantity of labour that is wasted—positively thrown away—in consequence of different provinces and countries striving to produce commodities for which they have not the best facilities, the mind of men would turn with disgust from the protective system, so tenaciously clung to by the Spitalfield weavers, and so absurdly lauded by their parliamentary patrons\*.

The existence of a profitable foreign trade in any article is wholly incompatible with the existence of a protecting system for it. Protection implies the necessity of a price beyond the average price in the market of the world; for were it otherwise, protection would neither be wanted nor could with decency be sought. With regard to France, eleven-fourteenths of her silk trade is for exportation, leaving only three-fourteenths for her home consumption, affording therefore a considerable portion of reward to industry. On the protection system Great Britain must have confined her silk manufacture to her home consumption, and remained deprived of participation with France and Switzerland in the custom of the world at large.

There can be no trade with foreigners in fact, but what involves some superiority in those who carry it on; and unless a nation possesses some peculiar advantage in reference to another nation, commercial

\* J. D. Hume, Esq., Secretary to the Board of Trade.

interchange could not take place between them. Equality would cause an equilibrium or stagnation as to export and import, that is, a destruction of all barter, so that each would be compelled to do every thing within itself, and to subsist on its own scanty range of productions. The peculiar faculties of a country cannot be duly developed under restraint of any kind, as is well shown by the French law, which prohibits the exportation of their first quality of silk. Were this law repealed, it would greatly encourage the silk growers, who enjoy uncommon facilities, and by lowering the price of the raw material, their silk manufacture would be encouraged. The same argument applies to the cotton and worsted manufactures of France. This branch of business is in great distress from the false direction given to industry by the government. Foreign manufactures may be fairly made to pay a moderate duty as the best way of providing revenue supplies to the state; but not such a tax as the manufacturer of the importing country can put into his pocket to reward his unprofitable industry. So applied, it becomes a legalized embezzlement of national resources for private and injurious ends: it is, in fact, the worst form of sinecure.

Since the opening of the English ports to French silks, the looms at Lyons for weaving fancy goods have greatly increased in number; while those for plain goods have considerably decreased, a line in which they possess no peculiar facilities over England. The best security against distress among the operatives of any country, is to apply their labour to the natural and most improved field of production. The relative situations and aptitudes of nations can be best judged

of by the emulation which exists between their operatives in the open, unprotected area of trade.

The complicated problem of wages in two or more countries cannot be solved by the analysis of a single class of productions: there may be in it peculiarities which tend to reduce wages below the average standard, though, when applied to the whole industry of nations, there is always in the market a quantity of labour whose excess or deficiency regulates its price. In making goods for a foreign market, their price, and of course that of the labour involved in them, must fall, if the admission of the foreign articles to be returned in exchange be prohibited. Close up any channel to the export of English labour, by the prohibition of your neighbour's peculiar articles of barter, and you diminish the demand proportionally for British labour. Thus new restrictions would very soon (namely, the moment the equilibrium of trade can take place between countries) aggravate the evil and distress; the inevitable result of prohibition. In most countries, but particularly in France and the United States, there is a great deal of misdirected labour, or a disturbed equilibrium of industry, which makes its level too low in one district, and too high in another. Nothing can give permanent relief on the great scale of the civilized world, but the entire suppression of the prohibitory system. A particular place possessing a monopoly may indeed gain by the prohibitory system for a time, but in the long run it would lose, and at any rate could never prosper but at the expense of the rest of the community.

To repair as far as possible the ruinous condition of the French manufactures, resulting from the revocation of the edict of Nantes, and at the same time to

flatter the pride of its profligate author Louis XIV., his celebrated minister Colbert established, two years after that event, an exclusive commercial system, and pushed with fresh spirit his favourite project of aggrandizing the productive arts by royal patronage; a policy pursued by his country ever since with extraordinary infatuation. Colbert's avowed purpose was to render France as much the mistress of the civilized world in manufacturing as he thought her to be in military glory; and to render her independent of the interchange of commodities with other kingdoms. On this occasion he extended the public grants of funds, honours, and immunities, to all adventurers who volunteered to advance his schemes; and he thus forced many branches of industry into a precocious development, which was mistaken for sound growth, until the vicissitudes of trade caused them in succession to wither and die. His was indeed the vainest of projects, for it aimed at nothing less than controlling and turning the wayward streams of industry, flowing from the wants, tastes, and caprices of millions of individuals, into a few artificial channels scooped out by the state. Conceiving that he was qualified to determine what was every man's interest better than he could himself, he framed a code of laws to regulate the processes of art in certain favourite manufactures. This presumptuous interference with private industry was not new. It had been attempted several years before, by the official publication of a book of instructions on dyeing, remarkable alike for the minuteness and the absurdity of its details. Entertaining a prejudice against indigo, Colbert forbade the dyers of blue cloth to put more than a certain proportion of that drug in

their woad vats. He enacted that the dyers of black should begin their process in the grand *tint*, and finish it in the little *tint*; permitting the dyers of the former style to have a certain number of ingredients in their possession, and those of the latter to have a smaller number; but allowing neither of them to have Brazil wood and some other specified articles in his dye-works.

How small an amount of manufacturing prosperity the exclusive policy of Colbert has produced; and how much agricultural, commercial, and manufacturing wealth has been either destroyed or checked in its natural progress, is very apparent in the history of France during the century and a half which have elapsed since his time. The immense resources of the country, and active intelligence of its people, have been spell-bound by the evil genius of their *grand monarque*, without their being aware of their cataleptic condition. A competent judge has asserted that the whole of the bounties which have induced adventurers to enter into remote speculations, as well as the excessive duties imposed on foreign articles cheaper than their own pet productions, have been sacrifices of national wealth without almost any compensation. The French system is a vain attempt to force capital into new directions independently of the genius and capabilities of the people.\*

The high prices which are created by the protective system are wholly incompatible with an extended foreign trade; for though they may be extorted by the influence of government from its dependents, for an inferior article, they cannot be obtained from foreign independent nations. A protective system necessarily

\* Dr. Bowring, M.P., in the Report on the Commercial Relations between Great Britain and France.

renounces the markets of the world for the home market, or if it seeks a foreign sale, it must bribe the purchaser by premiums, under the title of drawbacks on exportation. The commerce of France, which amounted in 1787, with less than 25 millions of people, to 25 millions sterling, amounted in 1830, with 33 millions of people, to only 25½ millions, notwithstanding the immense increase of population in the civilized parts of the world, and the extent of country opened by political events to commercial enterprise.

The external commerce of England, in 1787, was, for 9 millions of people, only 18 millions sterling, being 7 millions less than that of France, at the same period; and in 1830 it amounted to nearly 70 millions sterling. The shipping of France is little greater at the second period than it was at the first, while that of England has been doubled with her quadrupled commerce. Comparative statements furnished by the French-Custom House to our commercial commissioners, Messrs. Villiers and Bowring, of the exports and imports between England and France, and France and the Netherlands, throw much light upon the manner in which the balance of trade is adjusted between the three countries.

The official value of our imports from

France in 1831, was .. .. £.3,055,616

That of the imports of France from

this country was .. .. 897,179

From the above statements it will be seen that the excess of French exports to Great Britain over her imports from it, is to a great extent paid in barter through the Netherlands. Indigo, an article exported to the value of from three to five millions of francs from the



Netherlands into France, is imported by the former country from England merely in transit, because being one of our colonial productions, it cannot be directly admitted by the French laws. Again, it is from the Netherlands chiefly that the clandestine introduction of British goods into France takes place to an amount far greater than is necessary to explain the apparent incongruity between the value of what France takes officially from us, and what we take from France.

Thus a government suffers no less than its people from the prohibitory system. The difference of price between the foreign and the home made article might be made, very conveniently, a source of revenue, and so far diminish internal taxation; instead of which it is given to the protected fabrics at the expense of the treasury, and causes an increasing quantity of articles to be withdrawn by contraband from the revenue. As goods are raised in price in compliance with the clamorous manufacturers, they draw a larger sum directly out of the consumers' pockets, and indirectly compel him to make up by a tax for the deficiencies thereby created in the customs. Nor does the evil stop here: for the interests which had been protected by government look to government for relief, when that pressure, which inevitably impends, comes upon them: thus the government first produces sickness by pampering its offspring, and is then properly enough called upon to remedy the consequences. French prohibition presents an instructive history of the effects of violating the laws by which capital and labour should be governed: it is a vain struggle to attain what is unattainable; and it rejects the natural advantages which are at the command of industry, in

pursuit of objects beyond its reach. The wines of France, for example, afford unbounded means of exchange, but they have been sacrificed to iron and cotton goods; articles produced at an extravagant cost, and when produced, of no value in foreign trade, on account of the price of their production. The only article of French manufacture upon which foreign competition is allowed to act with tolerably fair play is silk: it is the least protected, and though not in so satisfactory a state as it might be, it has the best prospects; though the silk trade, like every other, shares in the suffering caused by the prohibitory system, since one prohibition entails another. The foreign raw material is taxed for the benefit of the silk grower; the manufacturer complains of the evil, and he persuades an inconsistent legislation to prohibit the export of silk of native growth, so that each is content to be juggled in his turn, in the name of patriotism.

The heavy taxes on foreign iron and foreign wood justify the French machinist in demanding and obtaining the exclusion of machines made abroad, and in requiring from manufacturers a monopoly price for those made by himself. But in shutting out the mechanisms of other countries, he has no choice of patterns to lay before his workmen, or for himself to improve upon. He has to begin the solution of many intricate, mechanical problems at the elementary principles, and proceeds, through a train of expensive constructions, to an equivocal conclusion, while he might at once have arrived at a certain one, by seeing the results of successful experiments already made in other countries.

The French consume iron in agriculture and the

arts, to the amount of 160 thousand tons annually, and as they pay at least 10*l.* per ton more to their iron masters for it than they could get it from England, they thereby sacrifice a sum of one million six hundred thousand pounds sterling per annum to that part of their protective system ; or in 22 years of their present iron laws, they have wasted 30 millions sterling of the national wealth in direct sacrifice, and double that sum indirectly. And to what purpose? Have their iron masters prospered, or have they improved their manufacture? On the contrary, they require now a higher price for their iron, relative to the English price, than when they first obtained their monopoly, and the largest of their companies has become bankrupt, while other adventurers have sustained ruinous losses.\*

In few of the protected articles of manufacture can France now sustain a competition with other countries, nor can she hope for much improvement as long as she deprives her artisans of the discipline and knowledge produced by that competition, which is no less valuable to the manufacturer than to the consumer. Meanwhile the fairest blossoms of her industry are devoured by the canker-worm of smuggling. It was estimated that 2,100,000 kilogrammes of goods were introduced clandestinely into France by bands of dogs, trained to the business, and called *chiens fraudeurs*. Tobacco, colonial produce, cotton-twist, and fabrics, are generally the objects of this illicit trade. The dogs carry from twenty to twenty-five pounds a-piece, amounting sometimes in value to from 20*l.* to 45*l.* sterling. The temptation to smuggle some

\* Dr. Bowring, M.P. *ut supra*.

articles is very great ; cotton yarn of the French number, 180 for example, which may be had in England for eighteen francs a pound, fetches in France forty francs. Of late there has been a considerable contraband, in our dyed woollen yarns, which brings as much as seventy per cent. of profit to the smuggler.

It has been estimated by the French Custom-House that about one-twelfth of the contraband articles are seized ; calculating from which datum and the value of the seizures, it would appear that British manufactures, to the amount of 230,000*l.*, are illicitly introduced by the Belgian frontiers alone. But as the goods realize a small part of their true value from the difficulties of exportation, and as one of the articles most extensively introduced, namely, cotton-twist, is protected from seizure after being deposited with the manufacturer, there is great reason to believe that the value of the contraband goods is ten times greater than the sum above stated, being probably somewhat more than two millions sterling.

Some data for estimating the amount of smuggling of English goods into France may be found in the facts known with regard to the smuggling of French goods into England. It appears that French silks, to the value of 350,000*l.*, are fraudulently introduced into this country every year ; of which those seized amount to no more than 9000*l.*, being only one thirty-ninth part, or about two and a half per cent., which represents the risk run, independent of the cost of packing, freight, &c. The risk incurred in France on account of its triple cordon of custom-houses, may be safely estimated at five per cent. greater than in England ; hence, leaving out the article of cotton-twist, which is

excluded only under a certain fineness, the introduction through the northern frontier of the Atlantic ports would be found to be enormous.

A state of things so offensive to the national honour, so ruinous to the finances, and so subversive of its morals, cannot but excite the strongest solicitude for a radical change in the system which first created and now fosters it.

The prohibitions at present in force by the custom-house legislation of Great Britain are very inconsiderable. The total amount of duties evaded by the clandestine import of French silks, brandies, &c. into this country does not exceed 800,000*l.* per annum, exclusive of tobacco-cargoes occasionally smuggled from the French bonding warehouses into Ireland.

The expenditure of the French treasury in premiums or bounties, and drawbacks to their manufacturers, has gone on of late years in a rapidly increasing ratio. In 1817, the whole amount so disbursed was only 3500*l.* but in 1830 it had mounted to nearly 600,000*l.* or one-fifth part of the whole Custom-House revenues of France; and if the system be continued it may eventually absorb all the resources of the state.

In cotton-wool, where the French customs received in the year 1830 only 380,000 francs from the importation, it expended in drawbacks and bounties 850,000 francs to the exporters. At this rate, had the whole cotton-wool imported been manufactured for export, it would have robbed the treasury of 8,000,000 of francs over and above the 6,000,000 paid to the Custom-House on its importation.

## NOTES.

NOTE A.—p. 88.

THE influence of the air and other refractive media, on the appearances of minute bodies viewed through a microscope, may be very conveniently studied on particles of starch;—those of arrow-root, for example. This, like all the varieties of fecula, consists of a transparent substance inclosed in a membranous bag of a spheroidal shape, which protects it from the solvent action of water, but which bursts by exposure to an elevated temperature, and allows the matter to show its soluble gummy nature. When a little arrow-root is dusted upon a slip of glass, and placed in the focus of a good achromatic microscope, it appears to consist of a congeries of black elliptic rings of considerable breadths, with very luminous centres (see *a*, Fig. 58).

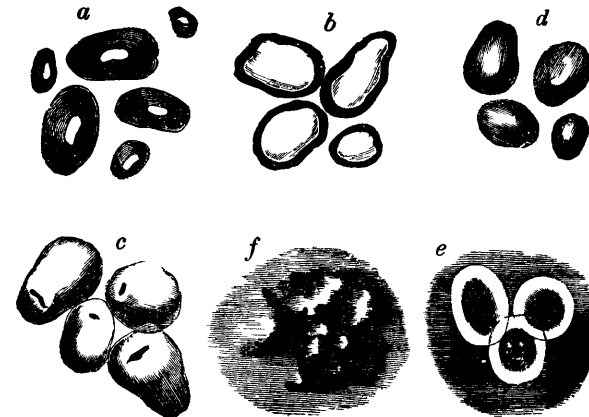

If the dust be now moistened with water, the particles will assume somewhat of their proper form of clear spheroidal lenses (or rather irregular ovoids), with darkish edges (see *b*); if it be imbued with oil of turpentine instead of water, they will be seen under the same form, but with clearer and sharper outlines, though altogether dimmer under the same light, and with black dots towards their centres (see *c*). In this case, the more refractive medium surrounding the particles lessens the deviation of light at their edges, and at the same time acts round them like a concave lens, so as to disperse outwardly the light which would be otherwise concentrated into their substance. If the particles be viewed after a little, when the oil has evaporated and left a solid film, they will appear like shadowy pearls (see *d*). In Canada balsam, thinned with oil of turpentine, they will no longer appear as spheroidal lenses brightest in the middle, but as filmy scales with a very black dot in the centre of their convexity (see *e*). After a few minutes, when the balsam gets inspissated by the evaporation of the volatile oil, the particles look as if they were concave or dished out in the middle part, with thickened up-turned borders, and more strongly marked with the black dots. When the balsam eventually becomes a concrete resin, they lose all distinctness of outline, most of them totally disappear, and the rest are recognizable only by gleaming spots of pearly white (see *f*).

These interesting metamorphoses were sketched for the wood-cut in the progress of their development by Mr. Sly, an artist familiar with the details of natural history, and skilful in representing them.

I had the pleasure lately of showing these phenomena to the distinguished entomologist W. Spence, Esq., F.R.S., and several other gentlemen who can bear witness to the fidelity of my observations. They lead to the conclusion, that in order to view any spheroidal or cylindrical object with advantage in the microscope, we should plunge it in

a medium of a refractive power a little, and but a little, different from its own. When the difference in this respect is very great, as between air and wool, for example, the interior structure of the fibres is not distinguishable, while the warty excrescences so common on certain coarse fleeces are well seen; but when that difference is very small, as between balsam and wool, the imbricated texture of the fibres is clearly developed, while the warts disappear; because being spongy they assimilate in optical quality with the varnish. Cotton filaments, however, are of such a form and constitution as to cause little deviation in the rays of light transmitted through them, and they may therefore be viewed with more propriety in air or water than in balsam; for this affects their edges, as it does those of starchy particles. Thin scales or parallel sections of any kind cause no deviation in the light falling perpendicularly on their surfaces, and are therefore, as far as their outline is concerned, correctly seen in air. The following liquids furnish a good gradation of refractive densities:—

	Index of Refraction.
Water . . . . .	1·336
Albumen (white of egg) . . . . .	1·360
Solution of common salt . . . . .	1·375
———— sal ammoniac . . . . .	1·382
Oil of lavender . . . . .	1·467
—— turpentine . . . . .	1·476
Canada balsam . . . . .	1·528
Oil of cloves . . . . .	1·535
Carburet of sulphur . . . . .	1·680

Mixtures of oil of turpentine and Canada balsam furnish media of refractive powers, intermediate between 1·476 and 1·528.

## NOTE B.—p. 125.

For the following interesting observations I am indebted to William Ogilby, Esq., Member of the Zoological Society of London, &c., &c., &c. :—

Great as are the changes which domestication has produced in the form and habits of the sheep, and innumerable as are the varieties resulting from the operation of this principle, there is perhaps none of our domestic animals whose original stock has been ascertained with greater precision, or is subject to less difference of opinion. Indeed we are acquainted with only two wild species of the sheep genus, from which this useful animal could possibly derive its origin: one the Argali (*Ovis Ammon*), which inhabits the loftiest mountain chains of Asia and North America; and the other, the Moufflon (*Ovis Aries*), called Musmon and Ophion by Pliny, which still abounds on the mountains of Asia Minor, Greece, Barbary, Corsica, and Sardinia, and which in the time of the Roman Republic appears to have been not less common in Spain and Portugal. It has been agreed on all hands, as well by ancient as by modern authors, that the latter species furnished the original stock of our domestic sheep; and the opinion is confirmed, not only by the perfect similarity which exists in the external and internal structure of the two animals, but by the facility with which they breed together, and even by localities inhabited by the Moufflon, surrounding as they do the very cradle of human civilization. The ancients, indeed, as Columella informs us, occasionally endeavoured to improve the domestic breed by crossing it with the wild animal, and in modern times some of our English breeds have been crossed in the same manner, by means of a wild ram introduced into this country by the celebrated General Paoli. The wool of the Moufflon is very short and coarse; the fleece, in fact, resembles that of the domestic sheep of tropical countries, being more

similar to hair than wool, but it improves rapidly by a little care and attention. In a state of nature, the wild sheep inhabits only the loftiest summits of the mountain ranges, living in flocks more or less numerous, and descending to the lower hills and valleys only when forced by the severity of the season. It is a bold, active, and intelligent animal, and exhibits nothing of the helpless or stupid character often ascribed to its domestic representative; but those who have seen the half-wild flocks of Wales and other mountainous countries are well aware that their apparent stupidity and dependence are the result of circumstances, and form no part of the animal's original character.

## NOTE C.—p. 253.

There are some records so tortuous as to put a tolerably clear intellect at fault. The evidence published by the Committee of 1832 upon the silk trade, though replete with valuable information, is of that mazy kind, and will create a vertigo in the brains of most readers; for authorities of apparently equal force are there exhibited acting upon the contested point at every angle of inclination or obliquity, and presenting to the political economist a problem, not unlike the famous dynamical one of the three bodies. I fear much that some parts of my chapter upon silk, notwithstanding much pains bestowed upon equilibration, will betray symptoms of the vortices out of which they have been extricated.

The account given in that parliamentary report of the method used at Lyons for estimating the fineness of silk, is as curious a mystification of a plain matter as a commentator could desire, and however unchallenged it might pass among the members at the time, it is calculated to 'puzzle posterity.' We read there, 'The weight is taken in grammes, 24 of which constitute 1 denier; 24 deniers

make 1 ounce; and 15 ounces 1 pound, poids de marc, which is the Lyons mode of selling silk. The weight of one thread of 400 ells is about  $2\frac{1}{4}$  grammes, when five threads are reeled together.'

Now, since 1 gramme weighs 18·82715 Paris grains\*,  $2\frac{1}{4}$  weigh 42·3 grains, which represent by the above document the weight of 400 ells of such silk thread, being nearly twenty times greater than the reality. And  $18\cdot8275$  grains (= 1 gramme)  $\times 24 \times 24 \times 15 = 162,666\cdot576$  grains, represent by the same document 1 pound, poids de marc, being from seventeen to eighteen times more than the real number, 9216 grains†.

My experimental inquiry into the weight of the denier, by which the value of silk per 400 ells (French) is estimated, has led to a very simple unravelling of this arithmetical skein. An ounce poids de marc of Lyons, and an ounce troy, are identical weights; but the former is divided into 576 parts = 24 drams  $\times$  24 deniers = 576 deniers; and the latter into 480 parts = 24 pennyweights  $\times$  20 grains = 480 grains. Hence the Lyons denier is to the English grain as  $\frac{1}{576}$  to  $\frac{1}{480}$ ; or as 0·8333 to 1·0000, that is, 100 deniers are equivalent to  $83\frac{1}{3}$  grains of our apothecaries and goldsmiths. Sixteen (not fifteen) Lyons ounces make one pound, poids de marc;  $16 \times 576 = 9216$  French deniers, or grains.

NOTE D.—p. 375.

How any grave son of Esculapius could so masquerade his learning on the public stage of a parliamentary committee, as to make a comparison between young persons working in a mill by night, and tadpoles shut up in a dusky pool, is beyond my comprehension. Did he not

\* *Traité de Physique, par M. Biot, tome i. Supplement; Tables Usuelles.*

† *Ibidem.*

know that vast multitudes of children are employed in mines, where day-light never penetrates, and that they grow up into as healthy and intelligent a race of men as may be found? The miners of Cornwall, Northumberland, Cumberland, and Leadhills, are not the abortive frogs which lack of sunshine should produce, according to this physiological sage. Excess of light is, I believe, less favourable to the due development of the human faculties, than its defect; a circumstance verified in the experience of the crews of whalers, who lose their vigour of mind and body under the long summer days of the Arctic Circle. Had Mr. Sadler *got up* his medical witnesses to prove that the factory evils were a matter of *moonshine*, he would have been pretty near the mark.

## APPENDIX.

THE relative numbers of the two sexes engaged in the different manufactures form a curious subject of comparison. The following are some of these proportions:—

	Male.	Female.
Cotton factories in Lancashire and		
Cheshire - - - -	100	103
Cotton factories in Scotland - -	100	209
Flax factories of Leeds - -	100	147
Flax factories of Dundee and East		
Coast of Scotland - - -	100	280

It deserves to be considered how different the proportion of Scotland is from that of England; and how well that difference confirms Sir David Barry's report on the superior

physical condition, hardihood, and strength of the Scottish women over the English.

The silk factories throughout the kingdom make little or no demand on muscular effort, and therefore employ a very small proportion of males. The wool factories, however, call frequently for exertion of bodily strength, and therefore employ a greater number of males than females. Here again the superiority of the Scottish women seems to be manifested, for a much greater proportion of them are employed in the woollen manufactories of Scotland than there are of Englishwomen in those of England. Worsteds, however, constitute the chief part of the woollen trade of Scotland, and they may, to a great extent, be worked by women, whereas the clothing trade requires the labour of men.

Relative to age, fully *two-sixths* of the English cotton-mill operatives, and more than *three-sixths* of the Scottish, are under twenty-one.

In the cotton factories of Lancashire, the wages of the males during the period when there is the greatest number employed,—from eleven to sixteen are on the average 4*s.* 10 $\frac{3}{4}$ *d.* a-week; but in the next period of five years, from sixteen to twenty-one, the average rises to 10*s.* 2 $\frac{1}{2}$ *d.* a-week; and of course the manufacturer will have as few at that price as he can, and certainly not for any description of work which may be done by persons working at 4*s.* 10 $\frac{3}{4}$ *d.* In the next period of five years, from twenty-one to twenty-six, the average weekly wages are 17*s.* 2 $\frac{1}{2}$ *d.* Here is a still stronger motive to discontinue employing males as far as it can practically be done. In the subsequent two periods the average rises still higher, to 20*s.* 4 $\frac{1}{2}$ *d.*, and to 22*s.* 8 $\frac{1}{2}$ *d.* At such wages, only those men will be employed who are necessary to do work requiring great bodily strength, or great skill, in some art, craft, or mystery in which they are engaged, or persons employed in offices of trust and confidence. Again, as to the females there is no diminution of numbers between the period from eleven to sixteen, and the

period from sixteen to twenty-one; and for this obvious reason the wages do not rise in the case of females to more than an average of 7*s.* 3 $\frac{1}{2}$ *d.* in throstle spinning; and never much exceed this amount except in power weaving, where they may earn double the sum. The greater number of females is in the period of from sixteen to twenty-one; but there is a prodigious diminution immediately after; and none can be at a loss to tell the cause—it is the period when they marry. It is known by the returns, and the factory commission inquiries, that very few women work in the factories after marriage. It appears that the greatest number of the marriages of factory women take place before they reach their twenty-sixth year. They disappear about that time in the returns of the cotton mills; but an inspection of the tables will show, that if we are to search in the registers for the names of these females, it must be in the marriage registers, and not in the registers of the dead\*.

*Wages.* The small amount of the wages of the very young children employed in factories deserves notice, but should constitute a subject of satisfaction rather than of regret, because there will be less loss to the parents in withdrawing the youngest from the factories, and sending them to school.

Factory females have also in general much lower wages than males, and they have been pitied on this account, with perhaps an injudicious sympathy, since the low price of their labour here tends to make household duties their most profitable as well as agreeable occupation, and prevents them from being tempted by the mill to abandon the care of their offspring at home. Thus Providence effects its purposes with a wisdom and efficacy which should repress the short-sighted presumption of human devices.

The different rates of wages paid for the same work in the different districts of the United Kingdom is a subject deserving of the most serious consideration.

\* Dr. Mitchell's Statistical Report, Supplement to Factory Commission Report, p. 38.

WOOL.—WAGES OF MALES.

Districts.	Below 11	11 to 16	16 to 21	21 to 26	26 to 31	31 to 36	36 to 41	41 to 46	46 to 51	51 to 56	56 to 61	61 to 66	66 to 71	71 to 76	76 to 81	Poor's Rate per head in 1831.
Leeds, &c.	s. d. 2 0	s. d. 4 4	s. d. 9 9	s. d. 19 6	s. d. 22 5	s. d. 22 6	s. d. 22 6	s. d. 22 0	s. d. 22 0	s. d. 21 0	s. d. 21 11	s. d. 20 3	s. d. 16 8	s. d. 15 3	s. d. —	s. d. 5 7
Gloucester	s. d. 1 8	s. d. 3 1	s. d. 6 9	s. d. 11 5	s. d. 12 11	s. d. 13 3	s. d. 14 1	s. d. 13 8	s. d. 13 2	s. d. 11 4	s. d. 10 16	s. d. 13 2	s. d. 10 11	s. d. 11 3	s. d. 8 4	s. d. 8 8
Somerset	s. d. 2 1	s. d. 3 5	s. d. 7 10	s. d. 14 10	s. d. 16 3	s. d. 17 10	s. d. 19 9	s. d. 18 0	s. d. 18 0	s. d. 14 4	s. d. 16 3	s. d. 12 2	s. d. 12 0	s. d. 11 8	s. d. —	s. d. 8 9
Wilts	s. d. 1 9	s. d. 2 10	s. d. 6 4	s. d. 11 6	s. d. 13 10	s. d. 15 5	s. d. 13 7	s. d. 14 8	s. d. 14 10	s. d. 14 10	s. d. 12 2	s. d. 11 2	s. d. 7 5	s. d. 6 6	s. d. —	s. d. 16 6
Aberdeen	s. d. 2 6	s. d. 4 11	s. d. 7 9	s. d. 14 5	s. d. 14 10	s. d. 16 6	s. d. 14 10	s. d. 13 9	s. d. 15 1	s. d. 15 2	s. d. 12 4	s. d. 14 0	s. d. 10 1	s. d. 11 4	s. d. 12 0	s. d. —

WOOL.—WAGES OF FEMALES.

Leeds	s. d. 2 5	s. d. 4 6	s. d. 6 5	s. d. 7 0	s. d. 7 2	s. d. 7 7	s. d. 6 10	s. d. 7 1	s. d. 7 1	s. d. 5 1	s. d. 6 3	s. d. 3 5	s. d. —	s. d. —	s. d. 7 0	s. d. 5 7
Gloucester	s. d. 1 7	s. d. 2 7	s. d. 4 6	s. d. 5 6	s. d. 5 6	s. d. 5 5	s. d. 5 7	s. d. 5 6	s. d. 6 1	s. d. 4 4	s. d. 5 0	s. d. 5 0	s. d. —	s. d. 1 6	s. d. 7 0	s. d. 8 8
Somerset	s. d. 2 0	s. d. 2 10	s. d. 5 1	s. d. 6 6	s. d. 7 5	s. d. 8 1	s. d. 7 4	s. d. 6 11	s. d. 7 11	s. d. 7 11	s. d. 5 3	s. d. 3 3	s. d. 5 0	s. d. 2 0	s. d. —	s. d. 8 9
Wilts	s. d. 2 3	s. d. 2 9	s. d. 4 9	s. d. 6 0	s. d. 6 11	s. d. 6 2	s. d. 6 0	s. d. 5 9	s. d. 5 8	s. d. 5 5	s. d. 6 5	s. d. 5 3	s. d. 5 1	s. d. 4 0	s. d. —	s. d. 16 6
Aberdeen	s. d. 3 4	s. d. 3 7	s. d. 5 1	s. d. 5 7	s. d. 5 5	s. d. 5 4	s. d. 5 0	s. d. 5 3	s. d. 4 11	s. d. 4 11	s. d. 4 4	s. d. —	s. d. 4 6	s. d. 3 3	s. d. —	s. d. —

The wool being the old staple manufacture, and that most extensively distributed in the kingdom, affords the best means of comparing rates of wages.

Amount expended in support of the Poor per head for every one of the Population in the Counties of Lancaster, York (West Riding), Derby, Stafford, Leicester, Nottingham, Norfolk, Suffolk, Essex, Gloucester, Somerset, and Wilts; being the Counties in which the Factories are situated from which Returns have been obtained, in the Years 1801, 1811, 1821, and 1831.

Counties.	1801.	1811.	1821.	1831.
Lancaster - - -	£. s. d. 0 4 4	£. s. d. 0 7 4	£. s. d. 0 4 8	£. s. d. 0 4 4
York (West Riding)	0 6 7	0 10 0	0 6 9	0 5 7
Derby - - - -	0 6 9	0 10 1	0 8 2	0 6 7
Stafford - - -	0 6 1	0 8 5	0 7 10	0 6 5
Leicester - - -	0 12 3	0 14 8	0 14 2	0 11 6
Nottingham - -	0 6 3	0 10 9	0 7 10	0 6 5
Norfolk - - -	0 12 5	0 19 11	0 14 10	0 15 4
Suffolk - - -	0 11 4	0 19 3	0 17 9	0 18 3
Essex - - - -	0 12 1	1 4 8	0 17 7	0 17 2
Gloucester - -	0 8 8	0 11 7	0 9 1	0 8 8
Somerset - - -	0 8 10	0 12 2	0 8 7	0 8 9
Wilts - - - -	0 13 10	1 4 2	0 14 8	0 16 6

In regard to Aberdeen and the east coast of Scotland, a compulsory poor's rate is unknown; and at Paisley and the south-west of Scotland the amount raised by a rate for the



relief of the poor is very much lower than it is in any part of England. In respect of the wool manufacture, it will be seen that in the West Riding of Yorkshire, where the poor's rate is lower than in any of the other districts of England where wool is manufactured, the wages are the highest; and that in Somersetshire, where the poor's rate is higher than in the West Riding of York, the wages are lower; but they are there much higher than in the neighbouring county of Wiltshire, where the poor's rate is extremely high. The wages of Wiltshire, when contrasted with the wages of Aberdeen, where there is no compulsory relief, are in pecuniary amount lower; and when we take into account the great difference in the command of the necessaries of life which these wages afford in so cheap a country as the North of Scotland, we see that the condition of the Aberdeen operative is indeed much superior.

A similar result is observable in the silk manufacture, for at Derby, where the poor's rate is comparatively low, the wages are the highest; in Somersetshire, where the poor's rate is higher than in Derby, the wages are lower; and in Norfolk, Suffolk, and Essex, where the poor's rate is extremely high, the wages are far lower than in Somerset, and are indeed so low, that, but for such unquestionable evidence as these returns afford, we could scarcely have believed it possible. The contrast with Paisley, in Scotland, where the poor's rate, as compared with any part of England is exceedingly small, will lead to the same opinion.

FACTORY EDUCATION TABLE.

ENGLAND.	Numbers taken from the Returns.				Proportion in the hundred.			
	Read.	Cannot read.	Write.	Cannot write.	Read.	Cannot read.	Write.	Cannot write.
Lancashire - - -	11,393	2,344	5,184	8,553	83	17	38	62
Cheshire - - - -	3,092	344	1,630	1,806	90	10	47	53
Yorkshire - - - -	9,087	1,616	5,194	5,509	85	15	48	52
Derbyshire - - -	2,490	314	1,200	1,604	88	12	43	57
Staffordshire - -	3,530	718	2,603	1,645	83	17	61	39
Leicestershire - -	351	92	174	269	80	20	40	60
Nottinghamshire	948	127	455	616	88	12	43	57
Norfolk, Suffolk, } Essex - - - - }	1,914	433	608	1,739	81	19	26	74
Wiltshire - - - -	3,045	527	1,364	2,208	85	15	38	62
Somersetshire - -	2,040	229	591	1,678	89	11	26	74
Devonshire - - -	755	34	401	386	96	4	51	49
Gloucestershire -	4,556	379	1,983	2,952	92	8	40	60
Worcestershire -	21	—	16	5100	—	—	77	23
Warwickshire - -	105	15	81	39	88	12	68	32
Total - -	43,327	7,170	21,488	29,009	86	14	43	57
—								
SCOTLAND.								
Aberdeenshire -	4,336	305	2,133	2,508	93	7	46	54
Forfarshire - - -	4,879	237	2,425	2,691	95	5	47	53
Perthshire - - - -	1,601	96	1,054	643	94	6	62	38
Fifeshire - - - -	1,558	38	862	734	97	3	57	43
Clackmannanshire	213	6	754	65	97	3	70	30
Stirlingshire - -	795	23	547	271	97	3	66	34
Lanarkshire - - -	7,815	317	4,454	3,678	96	4	54	46
Renfrewshire - -	5,664	199	3,165	2,698	97	3	54	46
Ayrshire - - - - -	867	2	594	275	100	—	68	32
Bute - - - - -	430	4	310	124	99	1	71	29
Mid Lothian - - -	98	3	96	5	97	3	95	5
Total - -	28,256	1,230	15,794	13,692	96	4	53	47

In Scotland, in which, ever since the Reformation, education has been a subject of national interest, and where, for a long period, there has been a school establishment co-extensive with the church establishment, there is a greater proportion able to read and write. There is, however, still much room for improvement in that part of the kingdom. The returns from factories in rural districts are quite as favourable as those from the towns, which is attributable to the parochial schools.

---

Statistical Table of the Textile Factories of the United Kingdom, subject to the Factories Regulation Act, in which the Machinery is worked by Mechanical Power.

Constructed from the Parliamentary Returns, by ANDREW URE, M.D., F.R.S., for his 'Philosophy of Manufactures.'

District.	Name of Inspector.	Number of Manufactories.					Moving Power.			Ages of Operatives.						Operatives in the Manufacture of								Total Operatives.	
		Cotton.	Wool and Worsted.	Flax.	Silk.	Total.	Steam-Engines.	Water-Wheels.	Total Horse Power.	Under 11.		From 11 to 18.		Above 18.		Cotton.		Wool & Worsted.		Flax.		Silk.		Male.	Female.
										Male.	Fem.	Male.	Female.	Male.	Female.	Male.	Female.	Male.	Female.	Male.	Female.	Male.	Female.		
Scotland . . . .	Leonard Horner	159	90	170	6	425	224	214	10,152	285	343	6,629	14,902	8,904	19,113	10,529	22,051	1,712	1,793	3,392	10,017	185	497	15,818	40,358
North of England	Ditto . . . .	14	24	19	0	57	21	34	895	39	34	542	1,021	685	1,261	646	1,067	290	334	336	915	0	0	1,266	2,316
Westmoreland, including Kendall	Robert Rickards	0	13	4	0	17	3	26	248	27	23	146	196	203	115	..	..	257	159	119	175	..	..	376	334
Lancashire . . . .	Ditto . . . .	676	107	19	22	824	814	340	25,917	1,109	1,086	27,898	31,271	36,789	37,063	59,994	62,094	3,038	2,028	1,185	1,839	1,579	3,459	65,796	69,420
West Riding of Yorkshire . . . .	Ditto . . . .	126	601	64	7	798	582	526	17,468*	1,093	856	14,981	17,631	16,419	12,276	5,187	5,726	23,209	19,268	3,603	5,425	494	344	32,493	30,763
Cheshire . . . . .	Ditto . . . .	109	15	0	88	212	249	94	7,327	879	1,008	7,537	9,698	11,849	12,513	15,516	15,996	181	85	0	0	4,568	6,138	20,265	22,219
Flintshire . . . .	Ditto . . . .	5	0	0	0	5	5	4	258	..	..	202	241	250	458	452	699	0	0	0	0	0	0	452	699
Derbyshire . . . .	Ditto . . . .	60	4	..	1	65	33	63	1,436	28	28	938	1,287	2,825	2,863	2,776	2,849	35	1	..	..	30	35	2,841	2,885
Staffordshire . . .	Ditto . . . .	4	..	1	11	16	13	3	262	101	150	370	695	521	617	434	557	..	..	No return.	558	905	992	1,462	
Leicestersh., &c. †	R. J. Saunders .	69	106	48	76	299	?	?	?	1,055	1,563	2,938	6,951	3,274	8,516	3,171	5,438	1,434	2,666	404	1,085	2,258	7,847	7,267	17,030
West of England and Wales . . .	Jones Howell . .	..	319	2	25	346	?	?	?	181	193	3,646	3,009	5,017	4,905	..	..	8,234	6,564	315	377	295	1,166	..	..
South of Ireland.	Ditto . . . .	11	36	3	1	51	?	?	?	6	11	483	832	1,153	1,062	573	975	970	671	97	214	2	47	1,642	1,907
North of Ditto . .	L. Horner . . . .	17	0	22	0	39	17	23	895	8	13	893	2,088	970	2,050	980	1,672	..	..	891	2,479	..	..	1,871	4,151
	Total . . . .	1,250	1,315	352	237	3,154	?	?	?	4,811	5,308	67,203	89,822	88,859	102,812	100,258	119,124	31,360	27,369	10,336	22,526	9,969	20,438	151,079	193,544

\* One-half of this power is employed in the woollen and worsted factories.

† Messrs. Saunders and Howell have made no return of the steam-engines and water-wheels.

‡ Mr. Saunders inspects the following counties: Berks, Bucks, Cornwall, Derby (except the High Peak Hundred), Devon, Dorset, Essex, Hants, Herts, Kent, Leicester, Lincoln, Middlesex, Norfolk, Northampton, Nottingham, Oxford (part of), Suffolk, Surrey, Somerset (part of), Stafford (part of), Wilts (part of), Hull (neighbourhood of) in Yorkshire. There are no mills in the counties of Bedford, Cambridge, Huntingdon, Rutland, and Sussex. Mr. Howell inspects the English counties which are not specified above.